

Connection Procedure of One Cable per Phase with Single-core Cable

About This Document

The spare AC sealing plate (referred to as "spare sealing plate" hereinafter unless otherwise specified) is designed for PV grid-connected inverters SG320/350HX researched and manufactured by Sungrow Power Supply Co., Ltd.

This document mainly describes the connection procedure of one cable per phase with single-core cable. For detailed installation description of the inverter, visit the website at <http://support.sungrowpower.com/> to obtain the corresponding manual.

Cable Requirements

table 1 AC Cable Requirements

NO.	Type	Specification Cable Diameter(mm)	Cross-sectional Area (mm ²)
1	Four single-core outdoor copper cables	18 ~ 40	L1, L2, L3 wire: 70 ~ 185 PE wire: refer to "table 2 PE Wire Requirements"
2	Three single-core outdoor aluminum cables* Outdoor PE cable	18 ~ 40	L1, L2, L3 wire: 70 ~ 400 PE wire: refer to "table 2 PE Wire Requirements"

* A copper to aluminum adapter terminal is required when an aluminum cable is used.

table 2 PE Wire Requirements

PE Wire Cross Section	Note
S/2 (S: Phase wire cross-section)	The specifications are valid only when the phase wire and PE wire use the same material. If otherwise, ensure that the cross section of the PE wire produces a conductance equivalent to that of the wire specified in the table.

Installation Steps

1. Disconnect the AC-side circuit breaker and prevent it from inadvertent reconnection.
2. Loosen the two screws on the front cover of the junction box with the hexagon socket wrench provided. Open the junction box. During the wiring process, the limit rod attached to the cover keeps the junction box open.

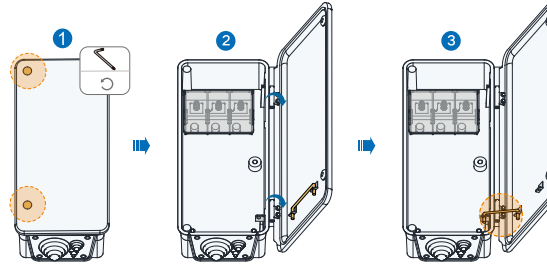

3. Loosen the screws on the bottom sealing plate with the hexagon socket wrench provided and remove the bottom sealing plate.

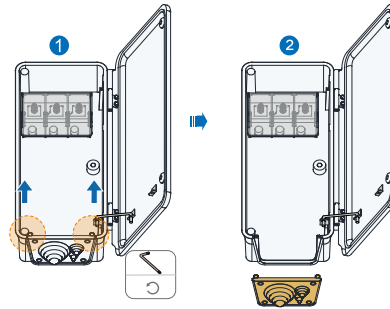

4. Loosen the four screws on the sealing plate with a wrench and remove the three-hole cable entry plate.

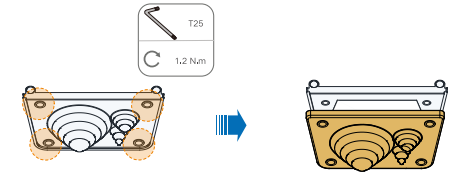

5. Replace it with the purchased five-hole cable entry plate and tighten the four screws on the sealing plate.

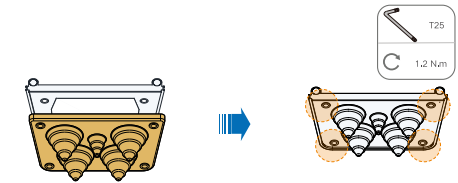

6. Cut off excess sealing ring according to the outer diameter of the cable.

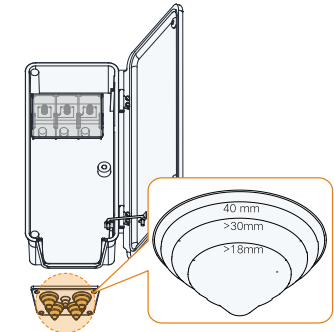

7. Lead the cable through the sealing ring and secure the screws on the bottom sealing plate.

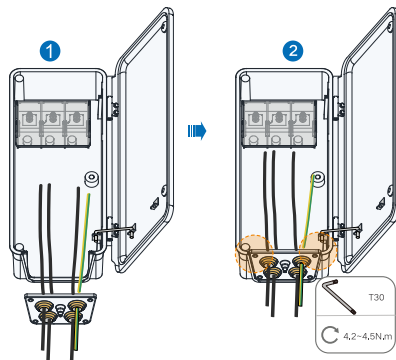

8. Open the protection cover.

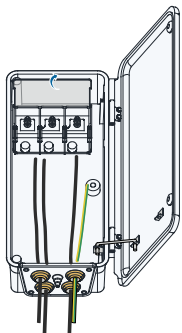

9. Fix cables with crimped OT/DT terminals to corresponding terminals.

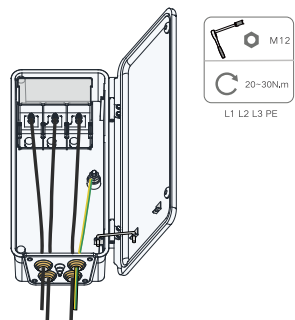

NOTICE

If a phase wire is connected to the PE terminal, unrecoverable damage may be caused to the inverter.

Ensure that the depth L of the socket used is not less than 28 mm.

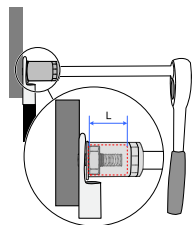

10. Close the protection cover.

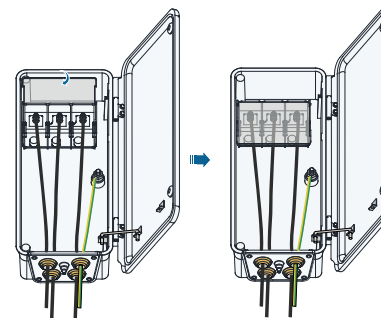

11. Remove the limit rod and place it in place. Close the junction block and tighten the two screws on its front cover with the hexagon socket wrench provided.

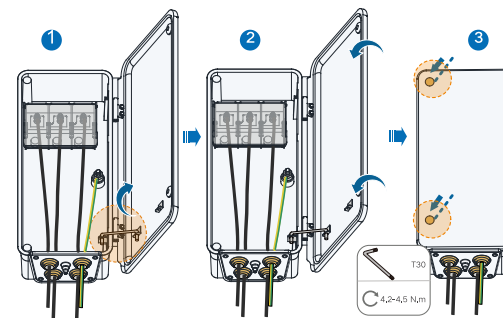

NOTICE

The maximum PLC communication distance from the box-type substation to the inverter is 800 m. Bind the three-phase cables with cable ties every 1 m.