

User Manual

Energy Management Unit

EMU200A



All Rights Reserved

All Rights Reserved

No part of this document can be reproduced in any form or by any means without the prior written permission of Sungrow Power Supply Co., Ltd (hereinafter "SUNGROW").

Trademarks

SUNGROW and other Sungrow trademarks used in this manual are owned by SUNGROW.

All other trademarks or registered trademarks mentioned in this manual are owned by their respective owners.

Software Licenses

- It is prohibited to use data contained in firmware or software developed by SUNGROW, in part or in full, for commercial purposes by any means.
- It is prohibited to perform reverse engineering, cracking, or any other operations that compromise the original program design of the software developed by SUNGROW.

About This Manual

This manual gives instructions mainly on the transport, storage, installation, electrical connection, and regular maintenance of the product, yet not all-encompassing regarding all details. You may visit [www. sungrowpower. com](http://www.sungrowpower.com) or the website of the equipment manufacturer for more information.

Declaration

To ensure safe use of the product, please read through the below information carefully:

- 1 This manual is intended for personnel who are responsible for product installation or other work on the product. Users must have certain electrical and mechanical expertise, and be familiar with the electrical and mechanical schematics and the characteristics of electronic components. SUNGROW shall not be held liable for any personal injury or economic loss arising from the installation carried out by non-qualified personnel or not in compliance with the safety instructions specified in this manual.
- 2 All pictures, marks, and symbols in this manual are owned by SUNGROW. No part of this manual may be reproduced by any non-internal staff without the prior written authorization of SUNGROW.
- 3 The manual may be updated and revised from time to time, however, there still might be slight deviation from the real product or errors. In such cases, the actual product you have purchased should take precedence. You can find the latest version of user manual on the company's website, or reach your sales for it.
- 4 To ensure the safety of the installation personnel, the product, and the system, be sure to follow the safety instructions specified in this manual when installing the product. SUNGROW shall not be held liable for any personal injury or economic loss arising from failure to follow the instructions specified in this manual.
- 5 If maintenance on or alteration to this product is needed, please contact SUNGROW customer service in advance. The copyright of this user manual belongs to SUNGROW, and any rights not expressly granted are reserved. The content herein is subject to change without notice and may deviate from the actual up-to-date product.

Target Group

This manual is intended for qualified technical persons who are responsible for installation, electrical connection, and other relevant work on the product.

Installation can only be done by qualified technical persons. Qualified technical persons must:

- Have certain electrical wiring, electronic, and mechanical expertise, and be familiar with electrical and mechanical schematics;
- Have received professional training in the installation and commissioning of electrical equipment;
- Be able to respond quickly to dangers or emergencies that may occur during the process of installation and commissioning;

- Read through this manual carefully and have a good understanding of the relevant safety instructions;
- Be familiar with applicable local standards and relevant safety regulations on electrical systems.

How to Use This Manual

Read through this manual carefully before using the product, and keep it properly in an easy-to-reach place.

The manual may be updated and revised from time to time, however, there still might be slight deviation from the real product or errors. In such cases, the actual product you have purchased should take precedence. You can find the latest version of the manual at support.sungrowpower.com or reach your sales for it.

Symbols in the Manual

To ensure the safety of life and property for users when using the product and to improve the efficiency of product use, the manual provides relevant safety information, which are highlighted by the following symbols.

Symbols used in this manual are listed below. Please review carefully for better use of this manual.

DANGER

Indicates an imminently hazardous situation which, if not avoided, will result in death or serious injury.

WARNING

Indicates a moderately hazardous situation which, if not avoided, will result in death or serious injury.

CAUTION

Indicates a slightly hazardous situation which, if not avoided, may result in minor or moderate injury.

NOTICE

Indicates a potential hazard which, if not avoided, will result in device malfunction or property damage.



Indicates supplementary information, emphasis on specific points, or tips related to the use of the product that might help to solve your problems or save your time.

Contents

All Rights Reserved	I
About This Manual	II
1 Safety Instructions	1
1.1 Safety Signs on the Product	1
1.2 General Safety Instructions	2
1.3 Packaging, Transport, and Storage Safety	4
1.4 Installation Safety	5
1.5 Electrical Safety	7
1.6 Operation Safety	8
1.7 Maintenance Safety	8
1.8 Disposal Safety	10
2 Product Description	11
2.1 Networking Scenarios	11
2.2 Main Features	12
2.3 Dimensions	13
3 Mechanical Mounting	14
3.1 Installation Notices	14
3.2 Inspection Before Installation	15
3.3 Installation Tools	15
3.4 Location Requirements	16
3.5 Installation Method	17
3.5.1 Wall Mounting	17
3.5.2 Bracket Mounting	18
3.5.3 Ground Mounting	19
3.6 Installing IO Modules (Optional)	20
4 Electrical Connection	22
4.1 Electrical Connection Notices	22
4.2 Waterproof Terminal Description	22
4.3 Internal Structure	23
4.4 Connection Overview	25
4.5 Preparation Before Connection	26

4.6 Connection Steps	27
4.6.1 Grounding	27
4.6.2 RS485 Communication Terminal Connection	30
4.6.3 Optical Fibre (Optional).....	31
4.6.4 Power Supply Connection.....	31
4.6.5 PLC Wiring	33
4.6.6 DI/DO Port Connection	41
4.6.7 PID Dry Contact Connection (Optional).....	43
4.7 Post-wiring Processing	46
5 Commissioning	47
5.1 Operation Notices.....	47
5.2 Inspection Before Commissioning	47
5.3 Commissioning Steps	47
5.3.1 Power-on Operation	47
5.3.2 Logger Commissioning.....	48
5.3.3 PID Commissioning (Optional)	49
6 Troubleshooting and Maintenance	54
6.1 Maintenance Notices	54
6.2 Troubleshooting	54
6.3 PID Module Replacement (Optional).....	55
7 Appendix A: Technical Parameters	58
8 Appendix B: General Information	59
8.1 Quality Assurance	59
8.2 Contact Information	59

1 Safety Instructions

Be sure to read through this manual carefully before proceeding with the transport, storage, installation, operation, use, and maintenance of the device. All work should be done by strictly following the safety instructions mentioned in this manual to ensure the personnel safety. Improper use or misoperation may result in:

- Injury to or death of the operator or other people;
- Damage to the device or the property of the operator or other people.



- Safety instructions in this manual should only serve as a supplement and not all-encompassing regarding all the norms that need to be followed. All work should be carried out considering the actual situation on the site.
- SUNGROW shall not be held liable for damages caused by violation of safe operation requirements, general safety standards, and safety instructions in this manual.

1.1 Safety Signs on the Product

Signs on the Product

Observe all warning signs on the product at all times, which are:

Symbol	Description
	High voltage inside. Risk of electrical shock hazard when it is touched.
	PE (Protective Earthing) terminal, which should be grounded properly to ensure the safety of operators.

Labels Inside the Product

Observe all labels inside the product at all times, which are:

Symbol	Description
	Warning Electric Shock.
	Must wear insulated protection supplies.

1.2 General Safety Instructions

Compliance with Laws and Regulations

NOTICE

All work, including transport, storage, installation, operation, use, and maintenance, should be done in compliance with the local laws, regulations, standards, and specifications.

Personnel Requirements

NOTICE

Persons who perform operations on the device must meet the following requirements:

- Have received professional training in the installation and commissioning of electrical equipment, and have the necessary experience;
- Be able to respond quickly to dangers or emergencies that may occur during the process of installation and commissioning;
- Persons, who are responsible for device installation and maintenance, must be trained thoroughly and have a firm grasp of the correct operation methods and a good knowledge of safety precautions and applicable local standards of the country/region;
- Persons responsible for special types of work (e.g. electrical operations, working at heights) must have relevant qualifications as required by the local regulations of the country/region.

DANGER

- Do not wear any conductive object, such as watches, bracelets, bangles, rings, and necklaces, during the operation process, so as to avoid electrical burns.
- Do not smoke in the area where the device is located, so as to prevent fires, electric shocks, and explosions, which may result in personal injuries or property damages.

DANGER

Use specialized insulated tools during operation to avoid electric shock hazards or short circuits. The tools should have an insulation withstand voltage rating that meets the requirements of the applicable local laws, regulations, standards, and specifications.

⚠ WARNING

Wear specialized personal protective equipment during the process of operation, such as protective clothing, insulated shoes, goggles, safety helmets, and safety gloves.

⚠ WARNING

Personnel except for those who perform operations on the device should stay away from the device.

Tools Requirements**⚠ WARNING**

- **Ensure all necessary tools are ready, without any damage, and pass the inspection by a specialized agency. Do not use tools that have signs of damages or fail to pass the inspection. Make sure the tools are firm and secure.**
- **Understand how to use the tools correctly before starting using them to avoid personal injury or damage to the device.**

⚠ WARNING

- **Use a wooden or insulated ladder when working at heights to avoid getting an electric shock.**
- **Check if the ladder is in good shape and if its load capacity meets the requirements. Do not overload the ladder.**

Environment Requirements**⚠ DANGER**

Do not place the device near heat or fire, so as to prevent damaging the device or causing fires.

⚠ DANGER

Do not store flammables and explosives in the device area. Do not place the device in an environment with flammable, explosive gas or smoke, or perform any operation in such environments.

⚠ WARNING

Do not install the device in an area close to liquids, so as to avoid device malfunction or short circuits caused by ingress of liquids.

⚠ WARNING

When installing the device, ensure the foundation is solid and stable and has a load-bearing capacity up to the requirements of the device.

⚠ WARNING

Do not perform any operation on the product (including but not limited to, handling, installing, powering on, and maintaining the product, performing electrical connection, and working at heights) in harsh weather conditions, such as thunder and lightning, rain, snow, and Level 6 or stronger winds.

⚠ WARNING

The device should be kept in a clean, dry, and well-ventilated place and protected from dust and condensation.

⚠ WARNING

Do not install the device in a place with strong vibration, strong noise source, or strong electromagnetic field interference.

⚠ CAUTION

To prevent irrelevant personnel from operating the product by mistake or other accidents, please set up highly visible warning signages or safety warning tapes around the product.

NOTICE

Ensure the safety signs, warning labels, and the nameplate of the device are clearly legible.

1.3 Packaging, Transport, and Storage Safety

Packaging

The product is packed in a cardboard box with orientation markings that provide loading and unloading instructions.

Transport

- All work related to transport must be carried out in compliance with the applicable local laws and regulations of the country/region.
- Measures should be taken to fasten the goods during transport, so as to avoid damages to product packaging due to strong shaking or bumping.

- Get prepared for carrying its weight before handling the device to avoid getting hurt. This device should be moved by at least 3 people together.

Storage

- The place where the product is stored should be kept dry, clean, and well-ventilated, protected from hazardous gases.
- Do not store the product in a place where corrosives are kept.
- The packaged product should be stored in an appropriate environment. See "Technical Data" for the corresponding environmental parameters.

Unpacking and Inspection

- Non-qualified personnel are forbidden from disassembling the device or moving its components.
- Check if the product you have received matches the order you placed.
- Inspect the product for external damages or damages to its structural parts.
- Check if the safety signs, warning labels, and the nameplate on the product are all legible.

In case of any problem with the above-mentioned inspection items, contact SUNGROW in time.

1.4 Installation Safety

DANGER

During installation, do not perform any operation on the device when it is powered on. Do not connect or disconnect the cables when the device is powered on, as electric arcs or sparks may occur immediately when the cable core is in contact with the conductor, which may cause fires or personal injuries.

NOTICE

Installation should be conducted in compliance with the applicable local laws, regulations, standards, and specifications.

Installation Requirements

WARNING

Poor operating environments will affect the device's system performance!

- **Install the product in a well-ventilated place.**
- **Ensure the product's heat dissipation system or air vent is not blocked.**
- **Do not install the product in an environment with flammables, explosives, or smoke.**

Pre-installation

NOTICE

- Upon receiving the product, be sure to inspect it for damages. Contact **SUN-GROW** or the transport company immediately in case of anything abnormal.
- Be sure to have a good understanding of the safety instructions in this manual before performing any operation on the product.
- Please load/unload, handle, install, operate, and maintain the device by referring to the descriptions in this manual to ensure the safe use of the device.
- Before installing the device, ensure the cabinet is stable and not tilted.

During Installation

NOTICE

This product can only be used for purposes specified in this manual. Unauthorized alternations or use of parts and components not sold or recommended by **SUN-GROW** may result in fires, electric shocks, and other hazards.

NOTICE

Disconnect all electrical connection and the upstream input switch before installation, and ensure the device is voltage-free.

NOTICE

If drilling is required during installation:

- Wear goggles and safety gloves.
- Avoid the water pipes and electrical wires inside the wall when drilling.
- Cover the product to protect it from ingress of debris and dust.

Post-installation

NOTICE

After the device is installed, clear away the empty packaging materials in the device area, such as the cardboard box, foam, plastics, and ties.

1.5 Electrical Safety

Improper wiring may result in personal injuries. Operators responsible for electrical wiring must read through the safety instructions carefully before proceeding with this work.

DANGER

Before carrying out electrical connection:

- **Make sure the product is not damaged; otherwise, it may lead to danger.**
- **Disconnect the upstream input switch and ensure the device is voltage-free; otherwise, it may lead to electric shocks.**

DANGER

Improper or incorrect electrical wiring may result in accidents such as fires or electric shocks.

DANGER

Danger to life due to high voltage inside the device!

- **When performing electrical wiring, operators must wear proper personal protective equipment and use specialized insulated tools, so as to avoid electric shock hazards or short circuits.**
- **Ensure the cables are voltage-free using a measurement instrument before touching them.**
- **Please observe the warning signs on the device, and perform operations by strictly following the corresponding safety instructions.**

WARNING

For the device that needs to be grounded, connect the PE cable as the first step when installing it, and disconnect the PE cable at the very end of the process when removing it.

WARNING

Before operating the device, inspect the electrical connection and ensure the device is reliably grounded.

WARNING

If the power cable is not long enough, replace it with a new one. Do not add joints or welding spots to the power cable.

⚠ WARNING

- **Electrical connection must be performed by qualified personnel.**
- **All work related to wiring must be conducted in compliance with the applicable local laws and regulations of the country/region.**
- **Please observe the warning signs on the device, and perform operations by strictly following the corresponding safety instructions.**
- **Damages to the product due to incorrect wiring will not be covered by the warranty.**

1.6 Operation Safety

There is high voltage inside the device when it is running, and improper operation may cause personal injuries or property damages. Please perform operations by strictly following the safety instructions specified in this manual and other relevant documentation.

⚠ DANGER

When laying cables, keep the cables at least 30 mm away from the outer edge of the heat-generating components or areas, so as to protect the insulation layer of cables from aging or getting damaged due to high temperature.

⚠ DANGER

When the device is running:

- **Do not touch any live component of the device; otherwise, it may lead to electrical shocks.**
- **Do not touch any wiring terminal on the device; otherwise, it may lead to electrical shocks.**
- **Do not touch any hot part of the device (e.g. heat sink); otherwise, it may cause burns.**

1.7 Maintenance Safety

Improper maintenance may lead to personal injuries or property damages. Therefore, it is necessary to power off the device before maintenance and perform operations by strictly following the safety instructions specified in this manual and other relevant documentation.

⚠ DANGER

- **Before maintenance, disconnect the upstream power supply and PLC power supply first; otherwise, it may cause personal injury.**
- **Wait 25 minutes after the device is powered off, then measure the voltage and current with a specialized measurement instrument. Only when no current or voltage is present, operators, who wear protective equipment, can perform operation and maintenance on the device.**
- **Even if the device is shut down, it may still be very hot and cause burns. Please perform operations on the device wearing safety gloves after it cools down.**

⚠ DANGER

Do not touch the grid or the contacts and terminals inside the product that are connected to the grid; otherwise, it may lead to electric shocks.

⚠ WARNING

Power off the device before proceeding with maintenance.

⚠ WARNING

- **Repair of the device can only be performed by SUNGROW's service team or qualified personnel.**
- **Users are forbidden from performing repair and maintenance or replacing modules by themselves. Otherwise, it may cause severe personal injuries or property damages.**

⚠ CAUTION

To prevent irrelevant personnel from operating the product by mistake or other accidents, please set up highly visible warning signages or safety warning tapes around the product.

NOTICE

- **Do not use cleaning agents to clean up the device. Otherwise, the device may be damaged, and losses caused therefrom will not be covered by the warranty.**
- **If the paint on device's enclosure peels off or the enclosure gets rusty, repair it in time. Otherwise, the device performance may be affected.**
- **No component inside the device requires maintenance. Do not open the device (except for the junction box) or replace any internal components without authorization. Otherwise, damages caused therefrom will not be covered by the warranty.**
- **To minimize the risk of electric shocks, do not perform maintenance operations that are not specified in this manual. If needed, please contact SUNGROW for maintenance and repair services. Otherwise, damages caused therefrom will not be covered by the warranty.**

1.8 Disposal Safety

Please scrap the product in accordance with relevant local regulations and standards to avoid property damages or personal injuries.

NOTICE

- **All work related to product scrapping must be done in compliance with the applicable local laws and regulations of the country/region.**
- **Ensure the safety signs, warning labels, and the nameplate on the product are all legible before scrapping it.**

2 Product Description

2.1 Networking Scenarios

EMU200A is equipped with a Logger4000 inside, which EMU200A can be applied to various networking scenarios. It can access the inverter, box-type transformer, meteo station and meter in the PV power generation system through RS485 bus, and can also access the string inverter with PLC function produced by SUNGROW through PLC bus.

- EMU200A can transmit the collected device data to the background plant controller, such as Insight and SCADA, through the core switch.
- EMU200A can also transmit the collected device data directly to iSolarCloud through the 4G router.

Connected to background plant controller through a core switch

EMU200A can be connected to Insight or SCADA through a core switch, as shown below.

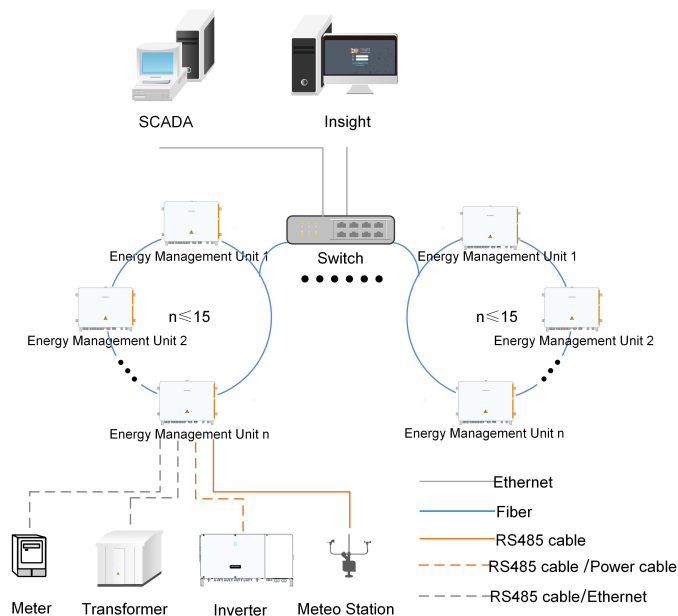

figure 2-1 Ring networking

When the ring networking is used, a maximum of 15 EMU200A can be connected to a ring network.

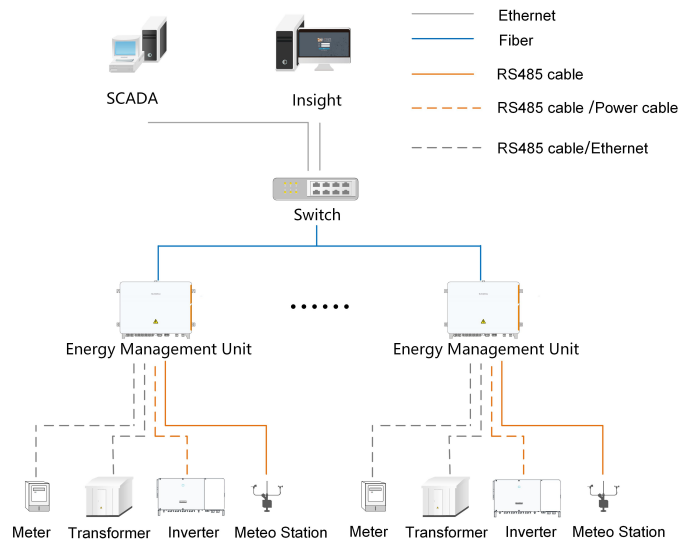
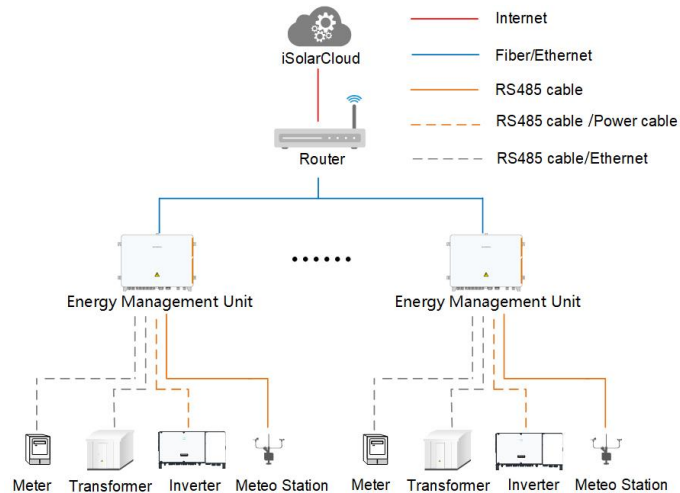

figure 2-2 Star networking

Connected to iSolarCloud through a router

EMU200A can be directly connected to the iSolarCloud through a router, as shown below.



2.2 Main Features

Flexible networking

- Support of RS485, Ethernet and MPLC communication.
- Support access of tracking system, box-type substation measurement and control, meter, meteo station and other equipment.

Convenient O&M

- Inverter batch parameter settings and firmware updates.

- Grid control instructions and power factor control, 30ms fast reactive power scheduling

Safe and reliable

- Electrical isolation and SPD for every port.
- (Optional) Built-in anti-PID and insulation resistance detection (ISO).
- IP65 protection.

2.3 Dimensions

The following figure shows the dimensions of the product.

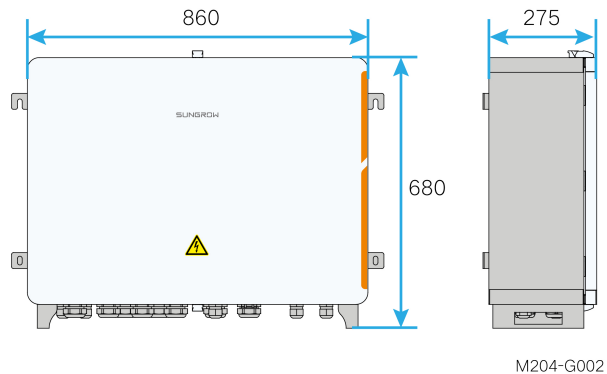

figure 2-3 Dimensions of the product(in mm)

* The image shown here is for reference only. The actual product received may differ.

3 Mechanical Mounting

WARNING

Respect all local standards and requirements during mechanical installation.

3.1 Installation Notices

Before installing the device, read through the “General Safety Instructions” first and ensure the requirements listed therein, as well as requirements mentioned in "Installation Safety", are all met.

DANGER

During installation, do not perform any operation on the device when it is powered on. Do not connect or disconnect the cables when the device is powered on, as electric arcs or sparks may occur immediately when the cable core is in contact with the conductor, which may cause fires or personal injuries.

WARNING

- Install the product in a well-ventilated place.
- Ensure the product’s heat dissipation system or air vent is not blocked.

NOTICE

Disconnect all electrical connection and the upstream input switch before installation, and ensure the device is voltage-free.

NOTICE

If drilling is required during installation:

- Wear goggles and safety gloves.
- Avoid the water pipes and electrical wires inside the wall when drilling.
- Cover the product to protect it from ingress of debris and dust.

3.2 Inspection Before Installation

Check the scope of delivery for completeness according to the packing list. The following items should be included:

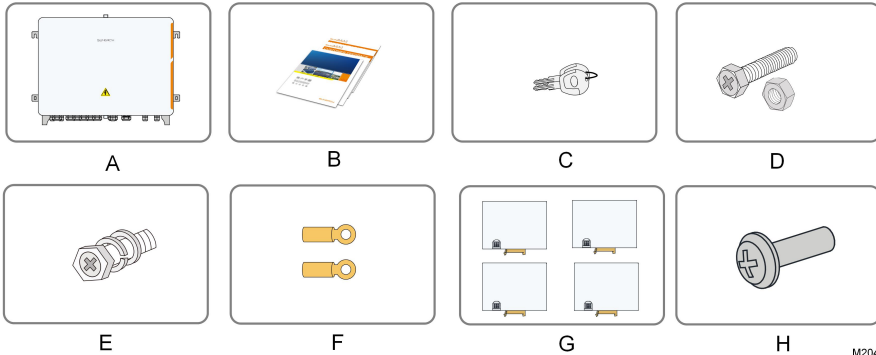

M204-1009

Item	Description	Sum
A	EMU200A	1
B	Documents, including certificate, warranty card, delivery inspection report, quick installation instruction, etc.	1
C	Keys	1
D	M10x45 bolt assembly	4
E	M6x14 bolt	1
F	OT terminal	1
G	IO module (optional)	≤4
H	M4x25 bolt	1



NOTICE

The device is carefully tested and inspected before delivery, but damage may be caused during shipping. Therefore, inspect the device before installation. If there any damage, contact the forwarding company or SUNGROW.

3.3 Installation Tools

Installation tools include but are not limited to the following recommended ones. If necessary, use other auxiliary tools on site.

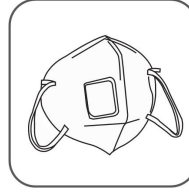
table 3-1 Tool specification

			
Goggles	Earplugs	Dust mask	Dust mask
			
Insulated shoes	Utility knife	Marker	Wrist strap
			
Level	Hammer drill (φ12)	Phillips screwdriver (M4, M6)	Slotted screwdriver (M2)
			
Rubber mallet	Wrench (18 mm, 21 mm)	Pliers	Wire cutter
			
Wire stripper	Tube crimp	Heat gun	Multimeter (≥ 1500 Vdc)

3.4 Location Requirements

- With the ingress of protection IP65, EMU200A can be installed outdoors.
- Ambient temperature: -30°C to +60°C , and ambient humidity: ≤ 95%, without condensation. Excessive moisture can damage internal components.

- Take anti-moisture and anti-corrosion measures.

3.5 Installation Method

⚠ WARNING

**Beware of the weight of the device throughout the installation process!
Tilting or falling of the device due to inappropriate processing can cause personal injury!**

The installation dimensions of mounting ears on the back of the device are shown in the following figure (unit: mm).

Wall mounting and bracket mounting are both available. Choose the corresponding installation method according to actual needs.

3.5.1 Wall Mounting

step 1 Mark the hole locations on the installation wall according to the foregoing installation dimensions.

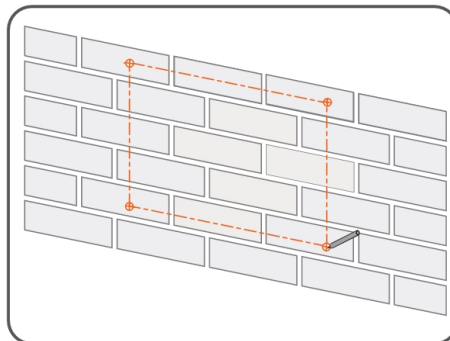

step 2 Drill holes on the marked locations.

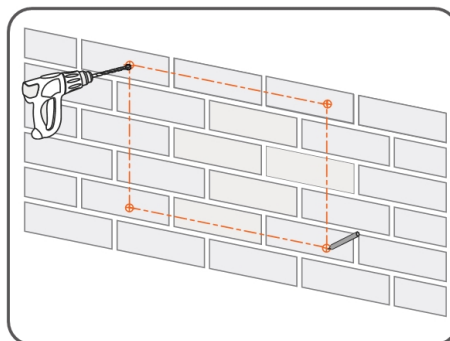

step 3 Place the M10X45 expansion sleeve(not included in the scope of delivery) into the hole, and tap it with a rubber hammer. Make it completely embedded in the wall.

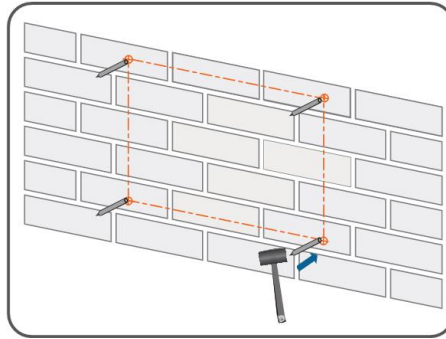

M204-I011



Select expansion bolts with proper length according to the depth of drilling.

step 4 Fasten the device on the wall in the order of nut, lock washer, flat washer, mounting ear.

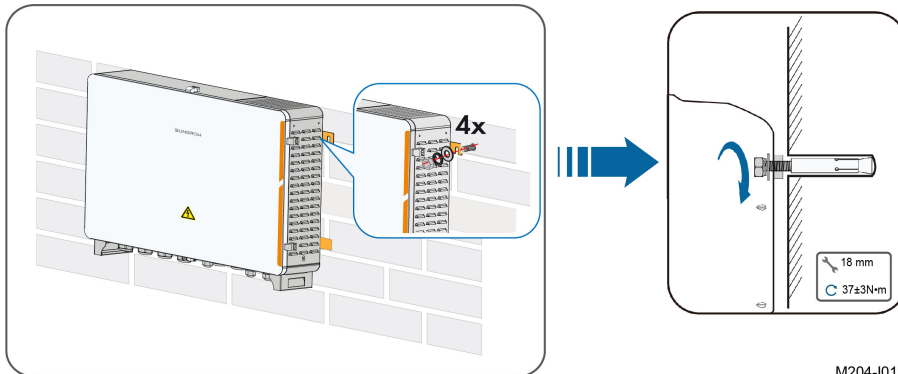

M204-I012

-- End

3.5.2 Bracket Mounting

step 1 Mark the hole locations on the mounting brackets according to the installation dimensions of mounting ears and drill holes on the marked locations according to bolt specifications.

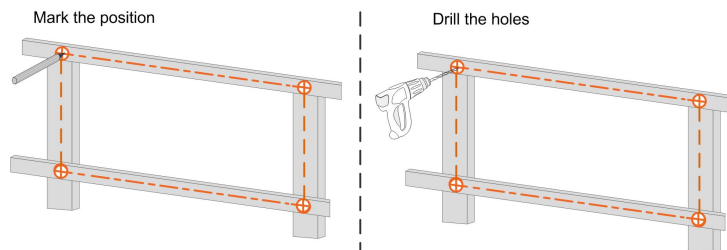

M201-I013

step 2 Fasten the device on the brackets in the order of M10x45 bolt, mounting ear, mounting bracket.

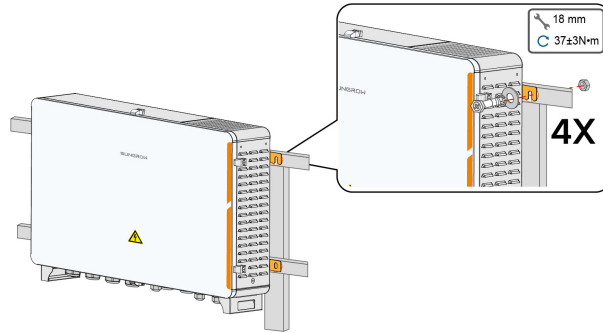

step 3 Check to ensure the device is firmly in place.

-- End

3.5.3 Ground Mounting

For the ground mounting, the device is fixed to the foundation via the installation holes in the bottom of the device (shown as A in the figure below).

To avoid excessive bending of cables, it is recommended that the bottom of EMU200A be 30 cm from the ground.

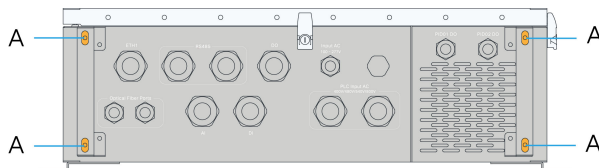

step 1 Construct the foundation according to the exterior dimensions of the device.

step 2 Pre-embed the foundation bolts in the four corners of the foundation, and the bolts used are M10.

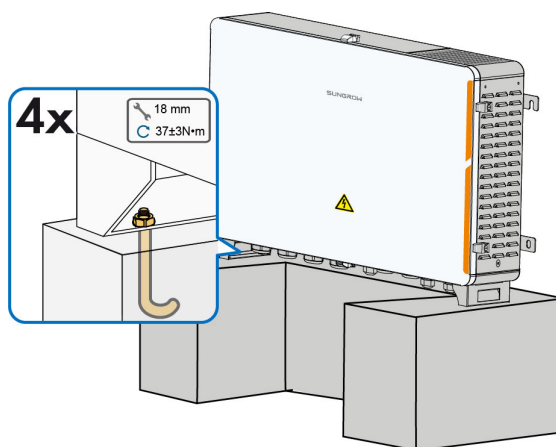

M204-I016



The foundation bolts are not in the scope of delivery

step 3 Secure the installation holes in bottom of the device to the foundation with a fastening torque of $37\pm 3\text{N.m}$.

-- End

3.6 Installing IO Modules (Optional)

This operation is required if IO modules are ordered.

step 1 Remove the IO modules assembly from the IO module deliverables.

step 2 Set communication address. Find the dip switch on the back, and set the communication address through the dip switch. The setting range of the communication address is from 1 to 15.

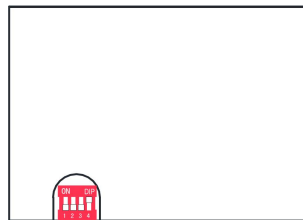

M201-I021

Example of communication address setting	Binary address	Decimal address
	0001	1 ($1 \times 2^0 = 1$)
	0010	2 ($1 \times 2^1 + 0 \times 2^0 = 2$)
	0011	3 ($1 \times 2^1 + 1 \times 2^0 = 3$)
⋮	⋮	⋮
	1111	$1 \times 2^3 + 1 \times 2^2 + 1 \times 2^1 + 1 \times 2^0 = 15$

NOTICE

The dip switch addresses on each IO module must be different.

step 3 Insert IO modules into the reserved area.

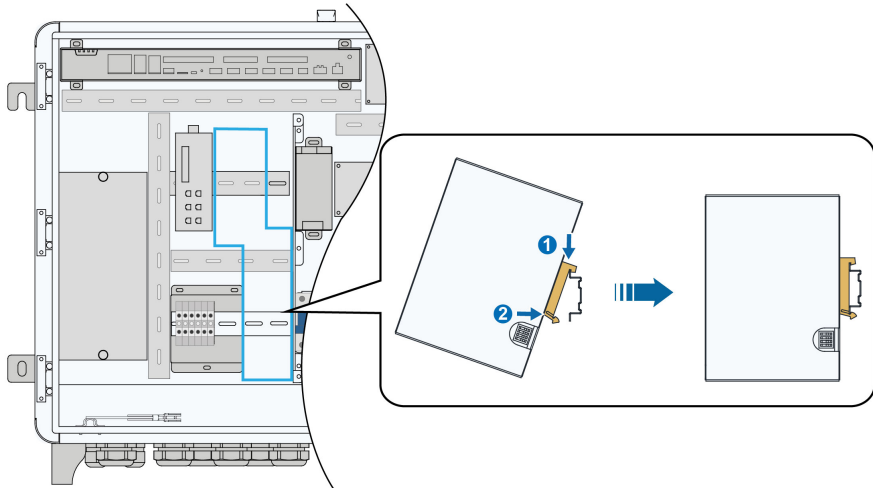

step 4 Install the four IO modules as shown in the following figure.

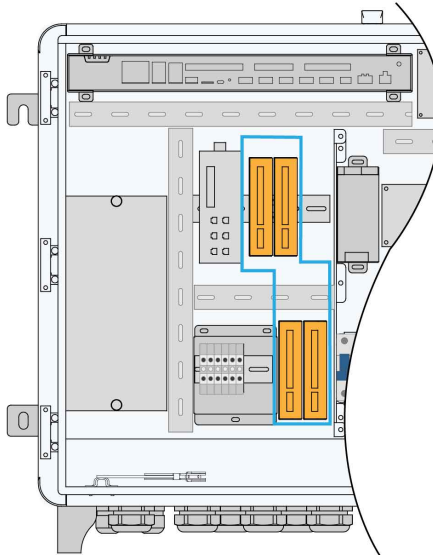

-- End

4 Electrical Connection

4.1 Electrical Connection Notices

Before performing electrical connection, read through the "General Safety Instructions" first and ensure the requirements listed therein, as well as requirements mentioned in "Electrical Safety", are all met.

⚠ DANGER

Before carrying out electrical connection:

- **Make sure the product is not damaged; otherwise, it may lead to danger.**
- **Disconnect the upstream input switch and ensure the device is voltage-free; otherwise, it may lead to electric shocks.**

⚠ DANGER

Danger to life due to high voltage inside the device!

- **When performing electrical wiring, operators must wear proper personal protective equipment and use specialized insulated tools, so as to avoid electric shock hazards or short circuits.**
- **Ensure the cables are voltage-free using a measurement instrument before touching them.**
- **Please observe the warning signs on the device, and perform operations by strictly following the corresponding safety instructions.**

⚠ WARNING

- **Electrical connection must be performed by qualified personnel.**
- **Please observe the warning signs on the device, and perform operations by strictly following the corresponding safety instructions.**

4.2 Waterproof Terminal Description

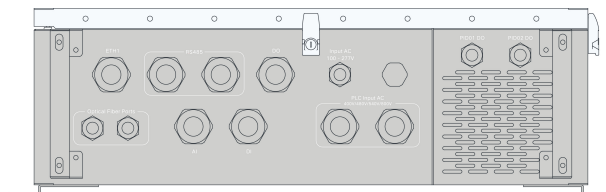

Mark	Description
ETH1	Waterproof terminals for Ethernet communication cables
RS485	Waterproof terminals for RS485 communication cables
DO	Waterproof terminals for dry contact output cables
AI	Waterproof terminals for analog input cables
DI	Waterproof terminals for dry contact input cables
Optical Fiber Ports	Waterproof terminals for optical fibers
PLC Input AC 400V/480V/540V/800V	Waterproof terminal for PLC communication cables
Input AC 100–277V	Waterproof terminal for AC 100–277V power cables
PID01 DO	Waterproof terminal for PID dry contact output
PID02 DO	Waterproof terminal for PID dry contact output
	Grounding point, on the right side of the device

4.3 Internal Structure

The internal structure of EMU200A is shown in the following figure.

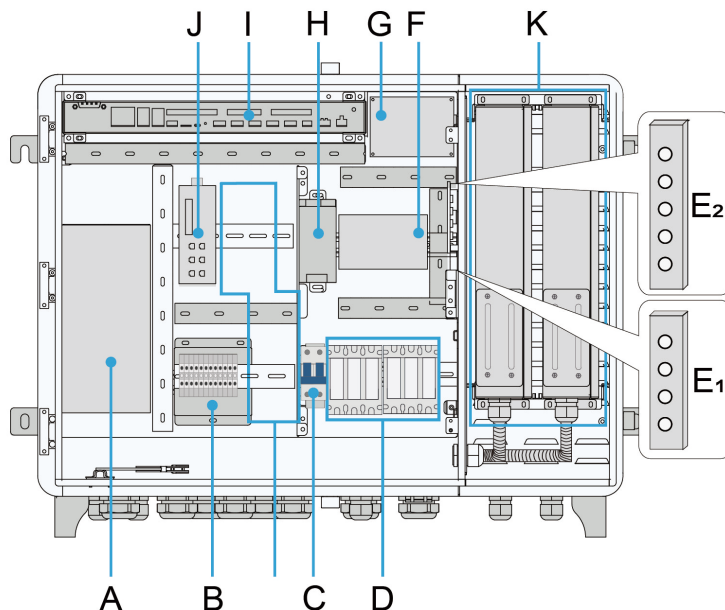

Item	Description	Recommended Cable Specification	Description
A	Optical fiber terminal box	—	Optional Must work with optical fibre ring switches For more information, please visit the distributor's official website
B	RS485 communication terminals	2 x (0.75~1.5) mm ² outdoor anti-ultraviolet twisted pair with a shielding layer	Cables not included in the scope of delivery
C	220Vac power supply terminals	1~1.5 mm ² outdoor anti-ultraviolet wire	Cables not included in the scope of delivery
D	AC fuse box	Recommended cable specifications: 4mm ² ~ 10mm ² , Cable withstand voltage: Cable grounding working voltage > 1000V	Cables not included in the scope of delivery
E	Grounding terminals	4mm ² ~ 10mm ² or 7 ~ 11AWG	Cables not included in the scope of delivery
F	SPD	—	—

Item	Description	Recommended Cable Specification	Description
G	PLC module	—	—
H	Switch power	—	—
I	Logger4000	—	SFP optical module can be inserted into SFP1 and SFP2 of Logger4000 SFP optical module is optional
J	Optical fibre ring switch	—	Optional Must work with the optical fiber terminal box For more information, please visit the distributor's official website
K	PID module	—	Optional

NOTICE

Internal components may differ as per selected product module. For details, refer to the product received.

4.4 Connection Overview

EMU200A can collect information of the inverter, the transformer, and other devices in the system, and upload it to the background monitoring system or iSolarCloud.

EMU200A supports various communication methods. The following describes the scenario where data is transferred to the background plant controller through a switch. Through RS485 cable or power line, EMU200A can realize RS485 communication and power line carrier communication (PLC), and collect device information, which can be transmitted to the back plant controller through optical fiber or Ethernet.

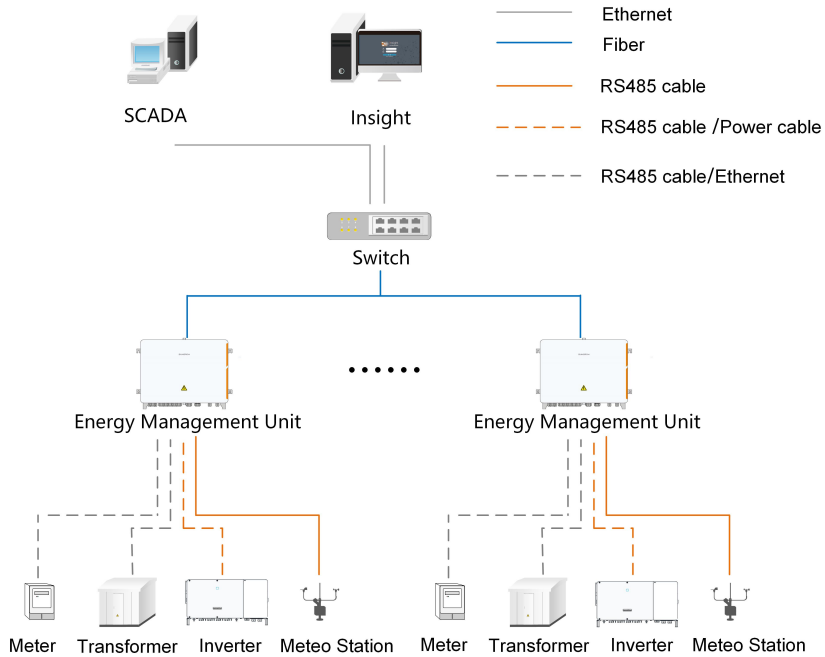

4.5 Preparation Before Connection

step 1 Open the cabinet. Unlock the door with the specific key, as shown in the following figure.

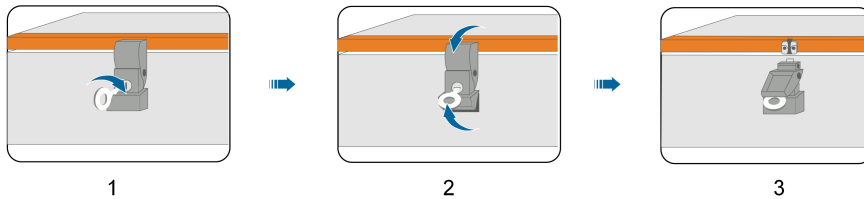

step 2 Unclip the top and bottom clips of the cabinet.

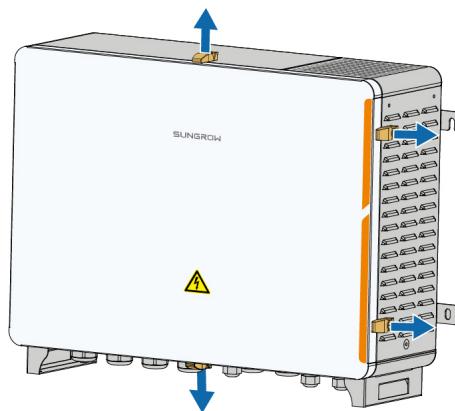

step 3 Disconnect the upstream input switch of the device, and turn the power switch inside the device to the "OFF" position to ensure the device is voltage-free.



M201-E028

step 4 Disconnect the switch of the transformer side.

step 5 Remove the protective cover inside the cabinet.

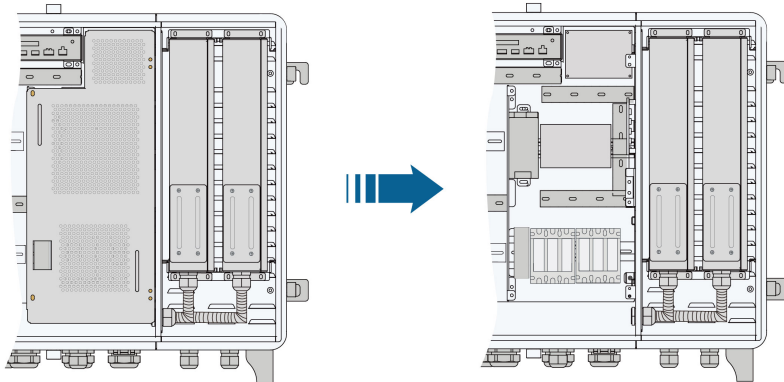

-- End

4.6 Connection Steps

4.6.1 Grounding

Safety Instructions

⚠ WARNING

The grounding cable must be grounded reliably! Otherwise,

- **Lethal electrical shock can be caused when a fault occurs!**
- **The device may be damaged by lightning!**

Brief Introduction

The device is designed with two grounding terminals: grounding copper bar inside the cabinet and external PE point.

On site, connect both grounding terminals reliably.

Preparation Before Installation

- Prepare the grounding cable.
- Strip the cable and crimp the OT terminal, and then use heat shrink tubing to tighten the cable and the OT terminal.

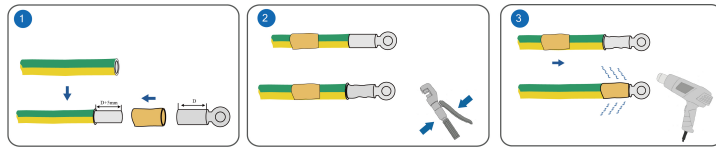

4.6.1.1 Cooper Bar Grounding

Position Description

The grounding copper bar is located inside the cabinet, as shown in the figure below.

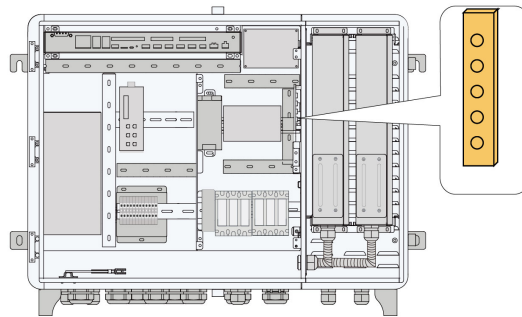

Wiring Steps

- step 1 Unscrew the waterproof terminal “PLC Input AC 400V/480V/540V/800V” at the bottom of the device.
- step 2 Connect the yellow-green grounding cable led from outside to the grounding copper bar inside the device through the internal waterproof terminal “PLC Input AC 400V/480V/540V/800V”.

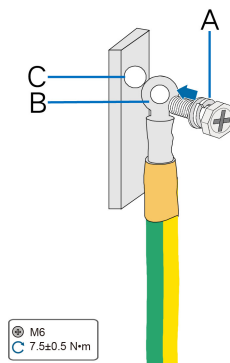

Item	Definition	Remark
A	M6x12 bolt	Not included in the scope of delivery
B	OT terminal	Included in the scope of delivery
C	Grounding hole	-

step 3 Secure the cable with bolt with a fastening torque of $7.5 \pm 0.5 \text{ N}\cdot\text{m}$.

step 4 Screw the waterproof terminal at the bottom of the device.

-- End

4.6.1.2 PE Point Grounding

Position Description

The external PE point of the device is shown by A in the figure below.

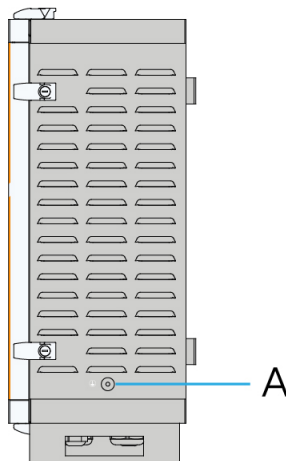

Wiring Steps

Anchor the prepared OT terminal to the grounding hole with bolt assembly with a fastening torque of $7.5 \pm 0.5 \text{ N}\cdot\text{m}$.

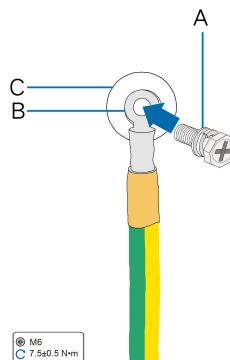

Item	Definition	Remark
A	M6 x 14 bolt assembly	Included in the scope of delivery
B	OT terminal	Included in the scope of delivery
C	Grounding hole	-

4.6.2 RS485 Communication Terminal Connection

Preparation Before Connection

NOTICE

When the EMU200A is connected to external devices by RS485, make sure that the external devices are protected against lightning.

Cable Requirements

Cables connected to the device must be 2 x (0.75~1.5)mm² in cross-sectional area.

Wiring Steps

- step 1 Unscrew the "RS485" waterproof terminal at the bottom of the device.
- step 2 Connect the RS485 cable led from outside to the communication terminal inside the device through the "RS485" waterproof terminal.
- step 3 Strip the cable jacket with a wire stripper.

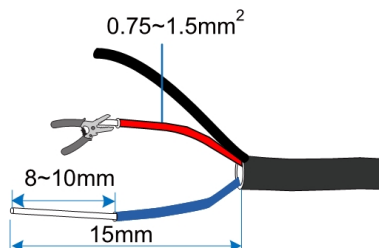

- step 4 Assemble proper cord end terminals to communication cable whose protective layer is stripped off and crimp them with a crimping tool.

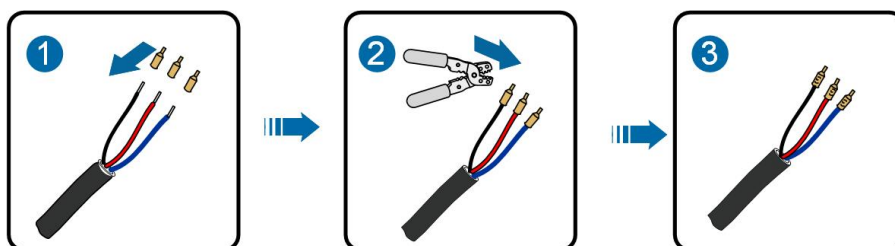

M204-E012

- step 5 Connect the cable to the corresponding terminal, and secure it with a screwdriver with a fastening torque between 0.5N·m and 0.6N·m.

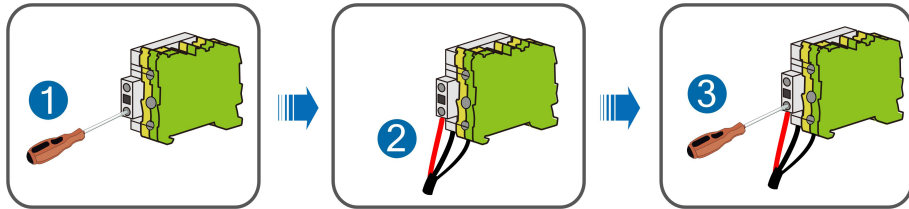

Mark	Definition
A	Connected to RS485–A, corresponding to upper-layer terminal
B	Connected to RS485–B, corresponding to lower-layer terminal
GND	Connected to RS485 cable shield

step 6 Gently pull the cable backwards to ensure firm connection.

step 7 Screw the "RS485" waterproof terminal at the bottom of the device.

-- End

4.6.3 Optical Fibre (Optional)

Preparation Before Installation

Before installation, prepare the required components. Components listed below are for reference only, and the actual situation may differ.

No.	Component
1	Pigtail: 24-input single-mode ST, 600mm
2	Jumper: Single-mode single-core ST-SC, 500mm
3	ST flange
4	Network cable, 460mm

Installation Steps

step 1 Unscrew the waterproof terminal "Optical fiber ports", and lead the optical fibre through the terminal.

step 2 Splice the optical fibre inside the splice box.



For details, contact SUNGROW.

step 3 Screw the waterproof terminal "Optical fiber ports".

-- End

4.6.4 Power Supply Connection

Preparation Before Installation

- Before wiring power supply, ensure that the micro circuit breaker is in the OFF position.
- Prepare the AC cable.

Installation Steps

- step 1 Unscrew the waterproof terminal "Input AC 100–277V", and lead the external power supply cable through the terminal.
- step 2 Strip the cable with a wire stripper.

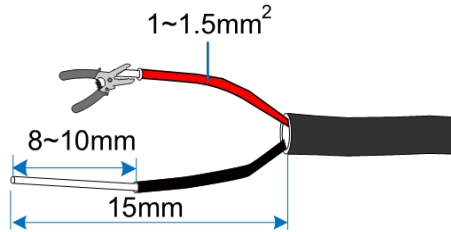

- step 3 Crimp the cord end terminal, and the recommended terminal model is LT015008.

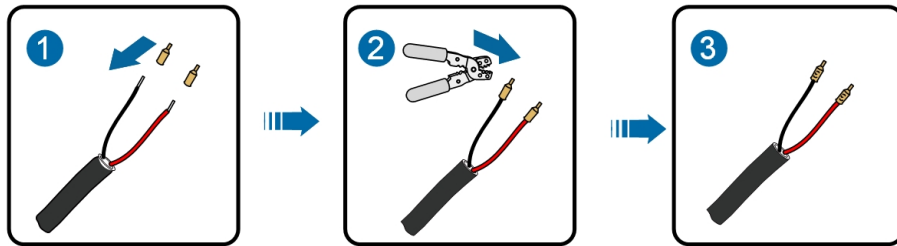

- step 4 Connect the cord end terminal to the corresponding terminal, and secure it with a screw with a fastening torque of 2.0N·m.

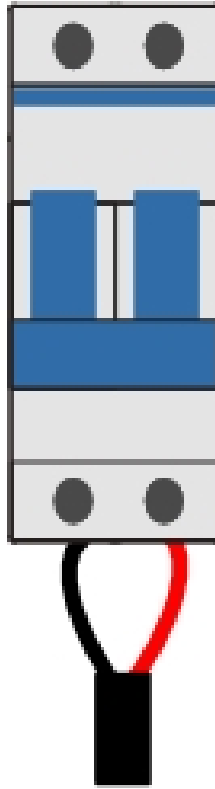

step 5 Screw the waterproof terminal "Input AC 100–277V".

-- End

4.6.5 PLC Wiring

This section gives an introduction to PLC wiring diagrams and rules for PLC wiring between different devices.

4.6.5.1 Application Scenarios

Device can be connected to a double-split transformer and a double-winding transformer. Wiring diagrams under these two scenarios are shown as follows. PLC1 refers to the MPLC node built in Logger4000. All cables run outside Logger 4000 in the wiring diagram, only for a clear illustration of the wiring principles.

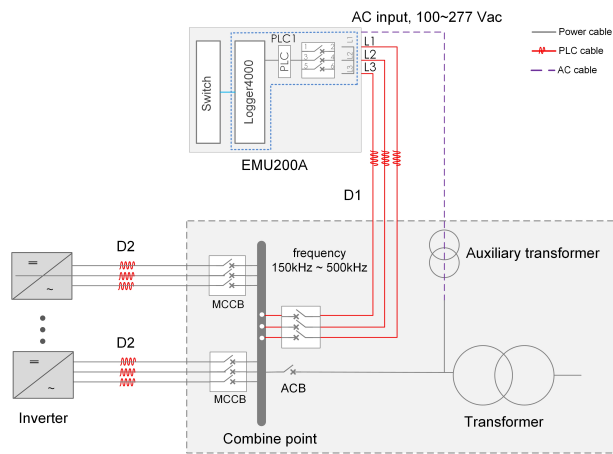

figure 4-1 PLC wiring diagram for a double-winding transformer

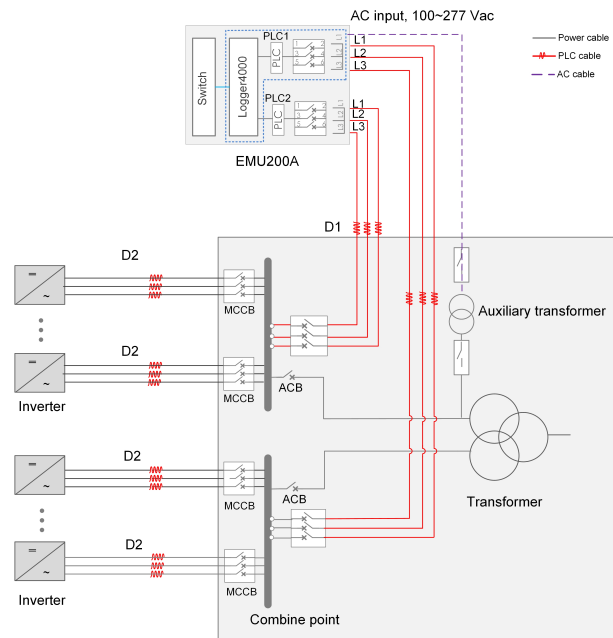



figure 4-2 PLC wiring diagram for a double-split transformer

Description of parameters in the diagrams is listed in the table below.

Parameter	Description	Cable Specification	Remarks
D1	Length of PLC cable from communication box to box-type transformer	<ul style="list-style-type: none"> Use outdoor UV-resistant multi-core copper AC cable with a core diameter of $\geq 2.5\text{mm}^2$. Cable isolation voltage $> 1000\text{V}$. Suggested length $< 10\text{m}$. Shorter cable leads to better communication. 	
D2	Length of PLC cable from box-type transformer to inverter	<ul style="list-style-type: none"> Length $\leq 990\text{m}$, if a multi-core AC cable is used. Length $\leq 790\text{m}$, if a single-core AC cable is used. The cable should be fastened every 1 meter, as shown in the figure below. <div style="text-align: center;">  <p>The diagram shows a horizontal cable segment with two curved brackets indicating fastening points. The distance between these two brackets is labeled as '1m'.</p> </div> If a parallel-pair cable, constituted by two different cables, is used, the difference in length between those two cables should be $\leq 5\text{m}$. 	$D1 + D2 \leq 1000\text{m}$
PLC module	Port input voltage	800 Vac	-
	Port supply voltage	24 Vdc	-
	Maximum number of inverters connected	80	-

4.6.5.2 PLC Wiring Rules

Rules for PLC wiring from box-type transformer to inverter

AC cables between the box-type transformer and the inverters can be laid in cable ducts, cable trenches, or pipelines. In addition, AC cable laying should be performed in compliance

with requirements for PLC wiring under the same box-type transformer, as well as those for PLC wiring under different box-type transformers.

- Requirements for PLC wiring under the same box-type transformer
 - 1 Only AC cables under the same box-type transformer can be laid in the cable trench. Diagram of PLC wiring under the same box-type transformer is shown below.

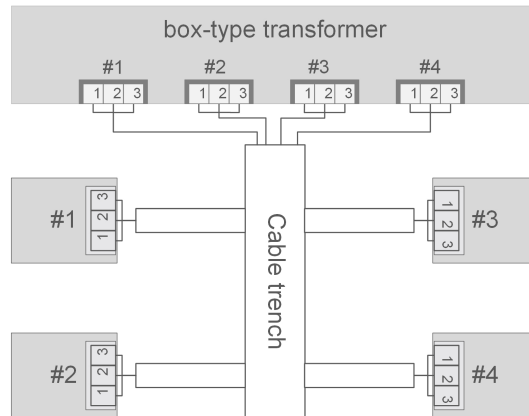

figure 4-3 Diagram of PLC wiring under the same box-type transformer

- 2 Cables can be laid in the cable trench in parallel, which however should not get entangled or knotted. There is no requirement for spacing between AC cables in the same trench.

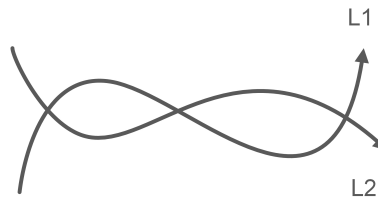

figure 4-4 Knotted PLC cable

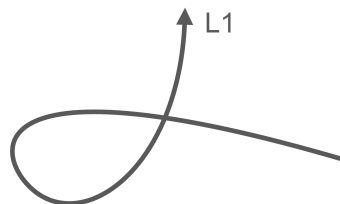

figure 4-5 Entangled PLC cable

- 3 If single-core cables are adopted, AC cables of the inverters should be fastened every 1 meter with cable ties. And cables between different inverters should be laid in parallel without getting entangled or knotted.
- 4 Requirements for spacing between LV AC cable and MV AC cable of the same box-type transformer are listed as follows.
 - In the case of two cables laid parallel to each other, the horizontal spacing between them should be >3m.

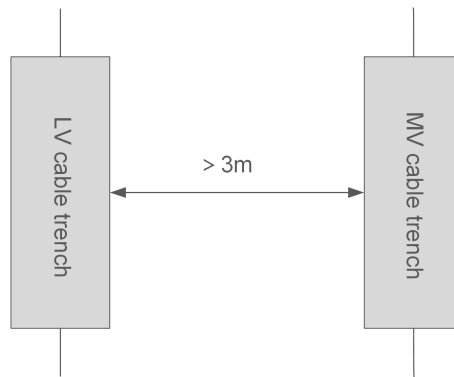

figure 4-6 Horizontal spacing between PLC cables (in parallel)

- In the case of two cables laid crosswise, the angle formed should fall in the range of 60°-120° and the vertical spacing between them should be >1m.

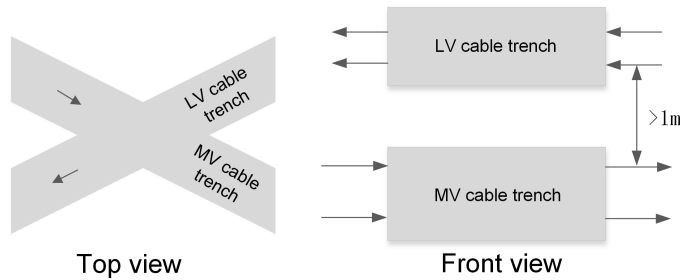

figure 4-7 Vertical spacing between PLC cables (crosswise)

- Requirements for PLC wiring under different box-type transformers

1 LV-side AC cables of different box-type transformers should be laid in their own cable trenches. Diagram of PLC wiring under different box-type transformers is shown below.

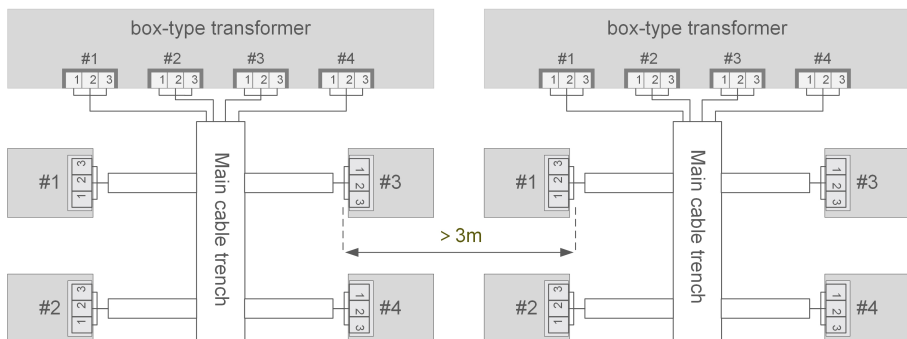

figure 4-8 Diagram of PLC wiring under different box-type transformers

2 Requirements for spacing between LV-side cable trays of different box-type transformers are listed as follows.

- In the case of two cables laid parallel to each other, the horizontal spacing between them should be >3m.

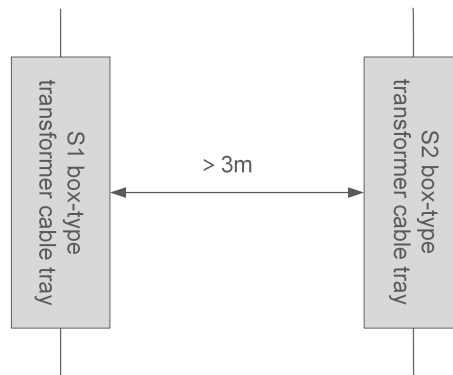

figure 4-9 Horizontal spacing between PLC cables (in parallel)

- In the case of two cables laid crosswise, the angle formed should fall in the range of 60°-120° and the vertical spacing between them should be >1m.

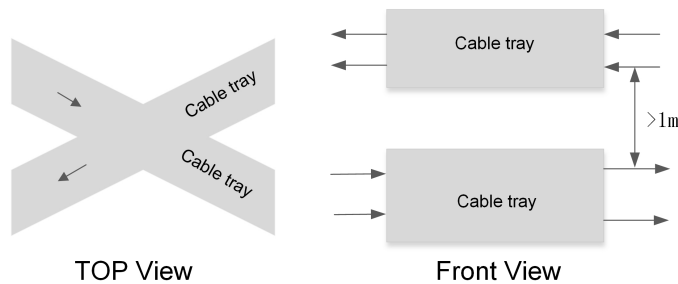

figure 4-10 Vertical spacing between PLC cables (crosswise)

- 3 Wiring requirements of MV AC cable and LV AC cable of different box-type transformers are listed as follows.
 - In the case of two cables laid parallel to each other, the horizontal spacing between them should be >3m.
 - In the case of two cables laid crosswise, the angle formed should fall in the range of 60°-120° and the vertical spacing between them should be >1m.

Rules for PLC wiring from communication box to box-type transformer

- 1 AC cables from communication box to box-type transformer should be laid parallel to each other, without getting knotted or entangled in the cable trench.
- 2 The coupling point for connecting the PLC cable to the box-type transformer busbar is recommended to be arranged in the position corresponding to the middle of the busbar. For instance, for an 8-branch busbar, the coupling point is suggested to be set corresponding to the 4th or 5th branch busbar; while for a 9-branch busbar, it is suggested to be set corresponding to the 5th branch busbar.
- 3 Use multi-core copper AC cable with a core diameter of $\geq 2.5\text{mm}^2$.
- 4 Rated power-frequency voltage to ground of three-phase AC cable should be $\geq 1000\text{V}$. Cable length should be $< 10\text{m}$. Shorter cable leads to better communication.

Parallel-pair cable laying rules for SG320HX inverter



Please refer to this paragraph for the parallel-pair cable scenario based on your actual needs. It is not applicable in areas such as North America.

A parallel-pair AC cable can be used, instead of a single cable, when installing the SG320HX inverter on the site. To minimize the impact on MPLC communication quality, the following requirements should be met.

- 1 The single-core cable should be fastened securely every 1 meter.
- 2 Spacing between the two cables should not exceed 0.15m.
- 3 If the two cables constituting the parallel-pair cable are not of the same length, the difference in length should not exceed 5m.

The aforementioned requirements should all be met, as shown in the figure below.

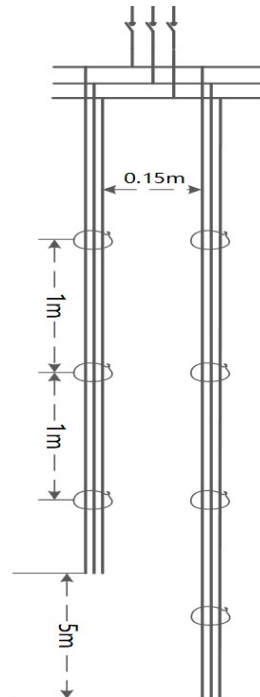

figure 4-11 Parallel-pair cable wiring diagram

The length of a parallel-pair cable constituted by two single-core cables should be $\leq 800\text{m}$, while the length of a parallel-pair cable constituted by two multi-core cables should be $\leq 1000\text{m}$. Communication may be interrupted if the cable length is out of this range. A greater impact may be exerted on communication if the two cables constituting the parallel-pair cable are of different lengths. It may give rise to a signal reflection, thus resulting in signal waveform distortion.

4.6.5.3 PLC Wiring

Pre-wiring preparation

- Before performing AC wiring, please ensure that upstream AC switches and circuit breakers inside the device are all disconnected.
- Please refer to "4.6.5.1 Application Scenarios" for PLC application scenarios and cable specifications.
- Please refer to "4.6.5.2 PLC Wiring Rules" for wiring diagrams under different application scenarios.

Steps of wiring

- 1 Unscrew the "MPLC 800V" waterproof terminal at the bottom of the device, and lead the external AC cable through the waterproof terminal.
- 2 Remove the protective layer of the cable using a wire stripper to expose the copper core, as shown in the figure below.

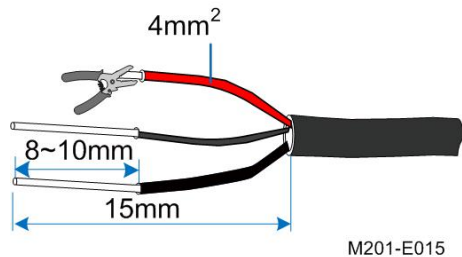

- 3 Crimp the OT terminals (OT2.5-6 is recommended).

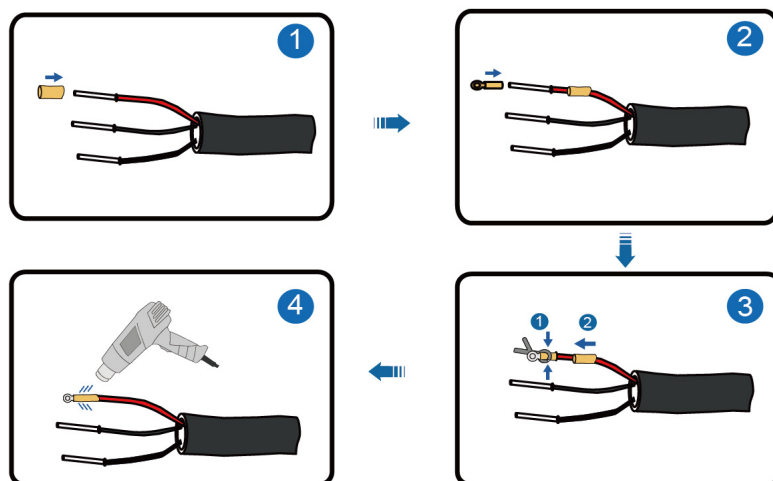

- 4 Connect the cable to the corresponding terminal, as shown in the figure below.

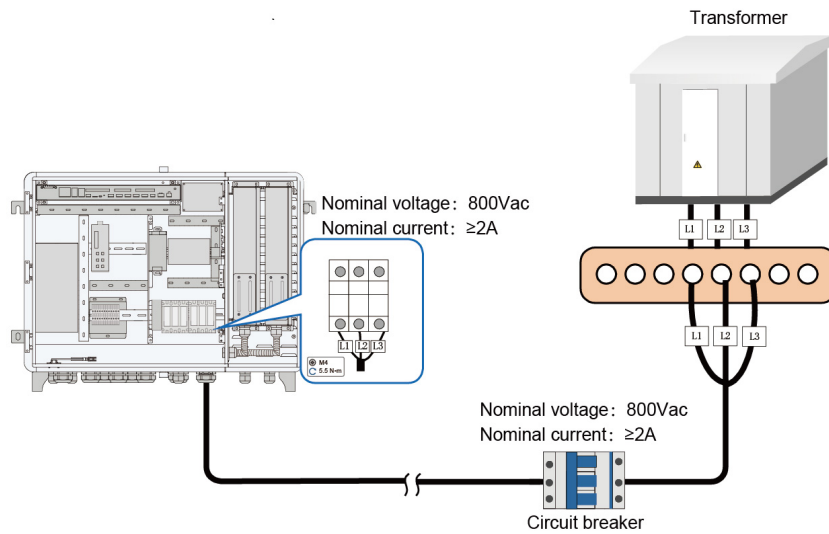

figure 4-12 Three-phase three-wire connection



The coupling point for connecting the PLC cable to the box-type transformer busbar is recommended to be arranged in the position corresponding to the middle of the busbar.



- For parameters of the circuit breaker on the box-type transformer side, you may refer to the parameters of EMU200A's internal circuit breaker in the above figure.
- Please pay attention to the phase sequence of cables and terminals in the wiring process.

- 5 Fasten the cables with screws after confirming the cables are properly prepared. Tightening torque: 5.5N·m

4.6.6 DI/DO Port Connection

If the purchased model is not equipped with the IO module, the DI/DO port must be directly connected to the logger. For details about how to connect the DI/DO port, scan the following QR code to view the *User Manual* of Logger4000.



If the purchased model is equipped with an IO module, the DI/DO port must be connected to the IO module. For details about how to connect the DI/DO port, scan the following QR code to view the *Quick Installation Guide* of IO Module.



4.6.7 PID Dry Contact Connection (Optional)

- The relay can be set as fault alarm output, and user can configure it to be a normally open contact (NO&COM) or a normally closed contact (NC&COM).
- The relay is initially at the NC terminal. It trips to another contact when a fault occurs to the device. However, the relay does not trip when an alarm occurs. External LED indicators or other equipment can be used for easier judging whether the inverter is in the faulty state.
- The following figures show the typical applications of normally open contact and normally closed contact.

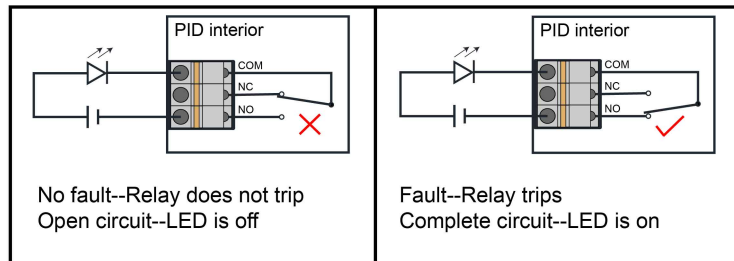

figure 4-13 Normally open contact

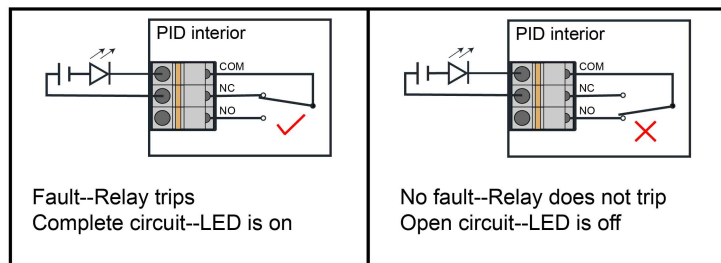
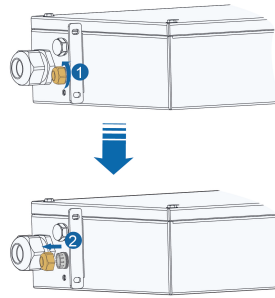

figure 4-14 Normally close contact



The cable is not included in the scope of delivery, and the recommended cable specification is 1~1.5 mm².

step 1 Unscrew the nut of the "DO" waterproof terminal at the bottom of the PID module.



step 2 Open the maintenance door of the PID module with a Phillips screwdriver.

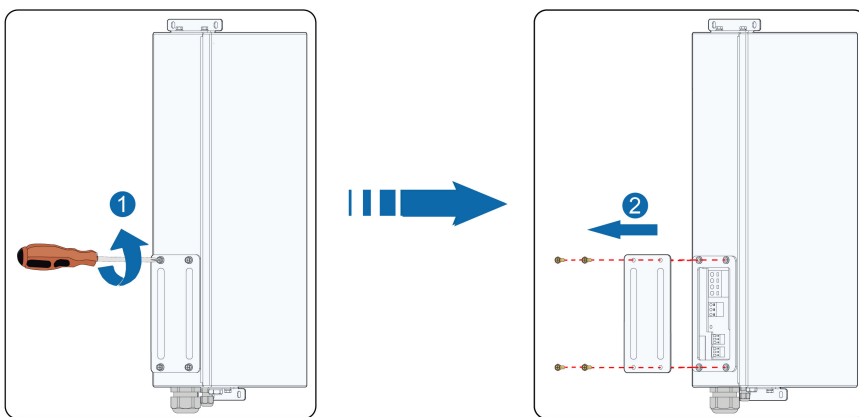

NOTICE

Store the removed nuts, maintenance door, and bolt assemblies in an accessible location and install and tighten them after the wiring is completed.

step 3 Lead the cable through the “PID01 DO” / “PID02 DO” waterproof terminal at the bottom of EMU200A and the “DO” waterproof terminal at the bottom of the PID module, and use a wire stripper to strip off the protective layer.

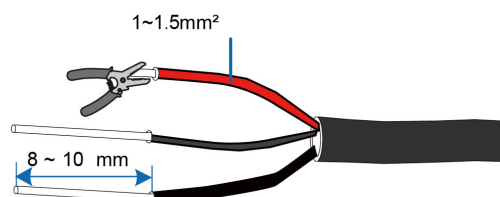

The cable is not included in the scope of delivery, and the recommended cable specification is 1~1.5 mm².

step 4 Install the cord-end terminal and press them with crimping pliers.

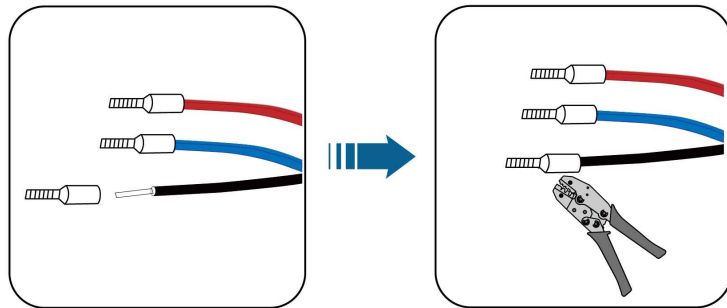

step 5 Unplug the terminals from the COM, NC, and NO interfaces on the PID module.

step 6 (Take NC contact as an example) Crimp the wiring terminals with a tightening torque of 0.2N.m.

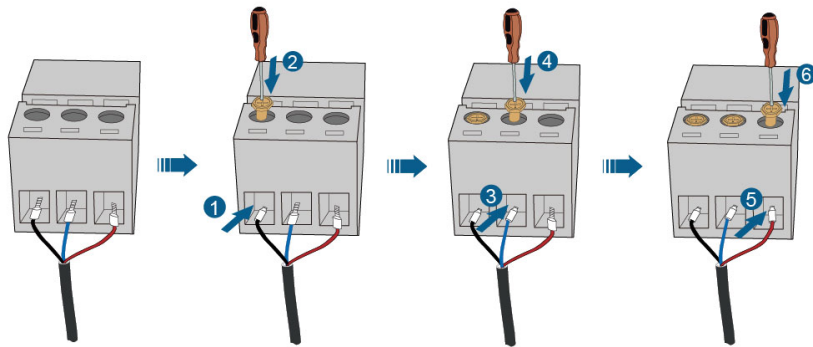

step 7 Connect the crimped terminals to the NC and COM terminals of the PID module.

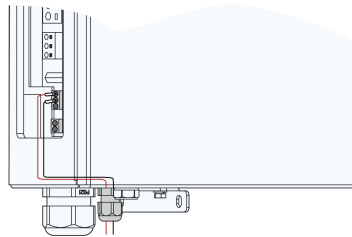

step 8 Gently pull the cable to ensure that it is connected firmly, and secure the nut.

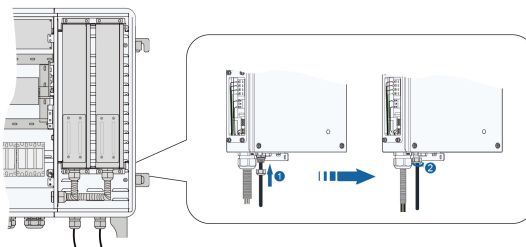

step 9 Install the maintenance door using the removed M4 screws with a tightening torque of 1.2N.m.

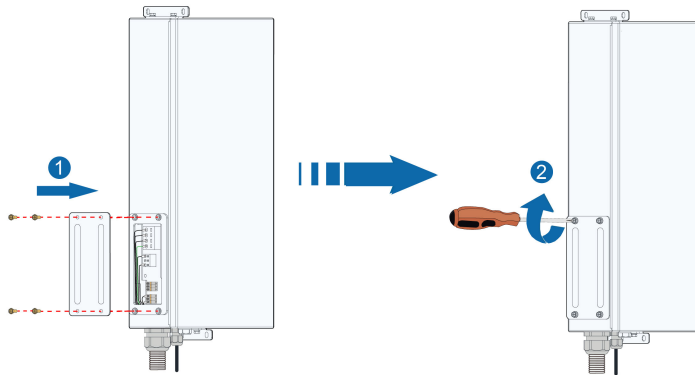

step 10 Tighten the “PID01 DO” / “PID02 DO” waterproof terminal at the bottom of the EMU200A.

-- End

4.7 Post-wiring Processing

NOTICE

Check whether the electrical wiring is completed correctly. If so, seal the cable inlet by filling the clearance around the cable with fireproof mud.

step 1 Gently pull the cable backwards to make sure the connection is secure after finishing wiring.

step 2 Install back the protective cover inside the cabinet.

step 3 Close the cabinet door.

-- End

5 Commissioning

5.1 Operation Notices

Before the device is put into operation, read through the “General Safety Instructions” first and ensure the requirements listed therein, as well as requirements mentioned in "Operation Safety", are all met.

⚠ DANGER

When the device is running:

- **Do not touch any live component of the device; otherwise, it may lead to electrical shocks.**
- **Do not touch any wiring terminal on the device; otherwise, it may lead to electrical shocks.**
- **Do not touch any hot part of the device (e.g. heat sink); otherwise, it may cause burns.**

5.2 Inspection Before Commissioning

No.	Inspection item
1	All cables are connected correctly and firmly.
2	The phase sequence of all cables is correct.
3	The internal and external grounding points of the device are reliably grounded.

5.3 Commissioning Steps

5.3.1 Power-on Operation

⚠ DANGER

Operators must wear proper personal protective equipment and use specialized insulated tools when powering on the system, so as to avoid electric shock hazards or short circuits.

Item	Description
1	Connect the internal fuse of EMU200A.
2	Connect the control switch of AC power supply.
3	Check whether the switch and 24V switch-mode power supply operate normally.

Item	Description
4	Observe running indicators of Logger4000. If the PWR indicator is steady on, RUN indicator flashing, WLAN indicator steady on and the FAULT indicator off, the EMU200A runs normally.
5	Connect the transformer-side circuit breaker.

5.3.2 Logger Commissioning

Item	Description
1	Connect PC to the Ethernet port of the switch inside EMU200A by using a network cable. The default IP address of Ethernet ports is 12.12.12.12, and the virtual IP address is 14.14.14.14
2	Configure the IP addresses of the PC and ports FE1~FE4 of the Logger on the same network segment. The IP address of the PC can be set to 12.12.12.X. The value of X ranges from 1 to 255 and cannot be 12. The subnet mask is 255.255.255.0. Or it can be set to 14.14.14.x. The value of x ranges from 1 to 255 and cannot be 14. The subnet mask is 255.255.255.0.
3	Enter the IP of the Logger4000, such as 12.12.12.12. or 14.14.14.14, in the PC address bar, to enter the corresponding Web interface.
4	Configure serial port parameters.
5	Add devices.
6	Configure device IP.
7	Configure iSolarCloud address if inverter data needs to be uploaded to iSolarCloud. <ul style="list-style-type: none"> • Accessed iSolarCloud site is "Chinese Server" by default. • In mainland China, set the site to "Chinese Server"; • In Europe, set the site to "European Server". • In Australia, set the site to "Australian Server". • In other regions, set the site to "International Server".
8	Access the Web interface of Logger3000 and check whether the running data of string inverters manufactured by SUNGROW is normal.
9	Create power plants through iSolarCloud App, and check whether the data displayed on iSolarCloud is normal.

Additional Description

To create power plant through iSolarCloud App, download and install the App and then proceed as follows:

- 1 Log into the Web interface of Logger4000 and click "About", to obtain the QR code.
- 2 Scan the QR code with the App or manually input the S/N to add communication device.

For more details, refer to Logger4000 User Manual, which can be obtained by scanning the foregoing QR code.

5.3.3 PID Commissioning (Optional)

Parameters of the PID module can be set on the embedded web of the logger.



Log in to the web and ensure that the PID module is online.

For more details, please refer to the user manual of the logger.

5.3.3.1 Operating Environment Requirements

Item	Parameter
Browser	IE11 above, Chrome65 above, Safari11 above
Minimum resolution	1024x768

5.3.3.2 Login Steps

step 1 Connect the Logger4000 to the PC network card.

step 2 Configure the IP address of the PC and that of the Ethernet ports (FE1 ~ FE4) of the Logger4000 to the same network segment. The default IP address of Ethernet ports is 12.12.12.12. The IP address of the PC can be set to 12.12.12.X and the subnet mask to 255.255.255.0.

step 3 Enter the IP address of the Ethernet port on the logger in the PC address bar to go the default interface.



If you accidentally forget the IP address of the Ethernet ports, you can log in with the virtual IP.

The virtual IP of the Ethernet port is 14.14.14.14.

step 4 Select the desired language in the upper right corner. Click **Login** and enter the login password pw1111 to enter the Web interface.



User types include **Ordinary User** and **O&M User**.

Ordinary users can view basic information, real-time fault, and device monitoring information of the logger.

O&M users not only have the permissions of the ordinary users, but also can set and modify information of devices connected to the logger.

In this manual, description is given by using permissions of O&M users as an example.



It is recommended to change the login password when logging in for the first time. The method of changing the password: click **O&M User**→**Modify Password** to set a new password.

If you forgot login password, contact SUNGROW and inform us the S/N and system time of the current device to obtain the dynamic password.

-- End

5.3.3.3 Commissioning Steps

Add PID device on the Logger4000 interface and set its initial parameters to enable PID suppression, recovery, and ISO functions.

step 1 Click **Device Maintenance**→**Device List**.

step 2 Connect PID device.

- 1 Click **Add Device** tab, and set the device information on the pop-up.

table 5-1 Set parameters of the PID device

Parameter	Description
Device Type	Choose "PID".
Port	Select the port to be connected to Logger4000 from COM1 to COM7.
Device Model	Choose "PID100".
Beginning Address	Enter the beginning address according to the parameters of DIP switch of the PID device, usually set as 250 or 251.
Quantity of Device	Set as the number of PID devices actually connected.

- 2 Click **Save**.

After the PID device is connected, check its communication status under Device List. If the indicator reads as , the device is connected successfully, as shown below.



No.	SN	Device Name	Device Model	Port	Device Address	Forwarding Address ID	Com Status	Operation
1	Y032848018	B037FA000-01	B037FX	COM2	1	2		
2	P0380COM-003	P0380COM-003	P0380	COM5	250	3		

step 3 Click **Device Monitoring** and select the PID module to be set in the left device bar.



- Click **Realtime Values** tab to check real-time data information such as AC insulation impedance, power output voltage, power output current, internal temperature, fault status, and alarm status of the PID device.
- Set parameters of the PID device to enable PID suppression, recovery, and ISO functions.

- 1 Click **Initial Parameter** tab to set relevant parameters of the PID device.

table 5-2 PID Module Parameters

Parameter	Description
Anti-PID Time (h)	<ul style="list-style-type: none"> – The duration of PID suppression, in the event of PID suppression and ISO detection working in turn. – Anti-PID time can only be integer values. – When the PID suppression is enabled, the ISO detection (day) is disabled.
ISO Detection Time (Day) (min)	<ul style="list-style-type: none"> – The duration of ISO detection, in the event of PID suppression and ISO detection working in turn. – ISO detection time can only be integer values. – When the ISO detection (day) is enabled, the PID suppression is disabled.
PID Recovery Time (h)	<ul style="list-style-type: none"> – The duration of PID recovery, in the event of PID recovery and ISO detection working in turn. – PID recovery time can only be integer values. – When the PID recovery is enabled, the ISO detection (night) is disabled.
ISO Detection Time (Night) (min)	<ul style="list-style-type: none"> – The duration of ISO detection, in the event of PID recovery and ISO detection working in turn. – ISO detection time can only be integer values. – When the ISO detection (night) is enabled, the PID recovery is disabled.
AC Insulation Alarm Threshold (kΩ)	<ul style="list-style-type: none"> – Resistance threshold to trigger the AC insulation alarm of the PID module. – The alarm threshold can only be integer values. – If the protection threshold < detection value < alarm threshold for a period longer than the insulation alarm time, the PID module will report the alarm code.
AC Insulation Alarm Time (s)	<ul style="list-style-type: none"> – Duration needed to trigger the AC insulation alarm of the PID module. – The alarm time can only be integer values. – If the protection threshold < detection value < alarm threshold for a period longer than the insulation alarm time, the PID module will report the alarm code.

Parameter	Description
AC Insulation Alarm Recovery Value (kΩ)	<ul style="list-style-type: none"> – The value that indicates the AC insulation resistance of the PID module returns to normal. – The alarm recovery value can only be integer values. – If the alarm recovery value < detection value for a period longer than the insulation alarm recovery time, the alarm of the PID module is cleared.
AC Insulation Alarm Recovery Time (s)	<ul style="list-style-type: none"> – Duration needed to clear the fault alarm, in which the AC insulation resistance of the PID module should be in the normal range. – The AC insulation alarm recovery time can only be integer values. – If the alarm recovery value < detection value for a period longer than the insulation alarm recovery time, the alarm of the PID module is cleared.
AC Insulation Protection Threshold (kΩ)	<ul style="list-style-type: none"> – Resistance threshold to trigger the AC insulation protection alarm of the PID module. – The protection threshold can only be integer values. – If the detection value < protection threshold for a period longer than the insulation protection time, the PID module will report the fault code and the protection will be triggered.
AC Insulation Protection Time (s)	<ul style="list-style-type: none"> – Duration needed to trigger the AC insulation protection alarm of the PID module. – The protection time can only be integer values. – If the detection value < protection threshold for a period longer than the insulation protection time, the PID module will report the fault code and the protection will be triggered.
AC Insulation Protection Recovery Value	<ul style="list-style-type: none"> – The value that indicates the AC insulation resistance of the PID module returns to normal. – The protection recovery value can only be integer values. – If the protection recovery value < detection value for a period longer than the insulation protection recovery time, the fault of the PID module is cleared and the protection is stopped.

Parameter	Description
AC Insulation Protection Recovery Time (s)	<ul style="list-style-type: none"> – Duration needed to clear the fault and stop the protection, in which the AC insulation resistance of the PID module should be in the normal range. – The protection recovery time can only be integer values. – If the protection recovery value < detection value for a period longer than the insulation protection recovery time, the fault of the PID module is cleared and the protection is stopped.
Trip Switch Enabling	<ul style="list-style-type: none"> – Enable: In the event of AC insulation faults, trip the RMU circuit breaker via DO port. – Disable: In the event of AC insulation faults, no action is taken and the RMU circuit breaker will not be tripped.
DO Associated with Trip Switch	<p>In the event of AC insulation faults, trip the RMU switch via DO port. Click the drop-down box and select DO associated with trip switch (DO which outputs trip signal).</p> <div style="border: 1px solid black; padding: 5px; margin-top: 10px;">  Setting of DO associated with trip switch can only take effect with trip switch enabled. </div>
Port of Associated Inverter	<p>Set the port number to which the associated inverter is connected according to actual conditions.</p> <div style="border: 1px solid black; padding: 5px; margin-top: 10px;">  Inverter shutdown or restart command is executed via this port in the event of the PID module detecting any abnormality. </div>
Number of Overcurrent Faults Within Seven Days	<p>The PID module will stop working in the case of over 5 overcurrent faults occurring within seven days. Please check whether the insulation resistance is normal. If it is normal, please click Clear to clear the count of overcurrent faults, and the PID module will resume work.</p>

2 Click **Save** to effect the parameter settings.

- Click **Device Information** tab to check the device model and software version.

-- End

6 Troubleshooting and Maintenance

6.1 Maintenance Notices

Before maintenance, read through the “General Safety Instructions” first and ensure the requirements listed therein, as well as requirements mentioned in "Maintenance Safety", are all met.

DANGER

Risk of personal injury or device damage due to improper maintenance!

- Be sure to use specialized insulated tools when performing high-voltage operations.
- Before maintenance, disconnect the upstream power supply and PLC power supply first; otherwise, it may cause personal injury.
- Wait 25 minutes after the device is powered off, then measure the voltage and current with a specialized measurement instrument. Only when no current or voltage is present, operators, who wear protective equipment, can perform operation and maintenance on the device.

WARNING

Power off the device before proceeding with maintenance.

CAUTION

To prevent irrelevant personnel from operating the product by mistake or other accidents, please set up highly visible warning signages or safety warning tapes around the product.

6.2 Troubleshooting

Fault	Possible Cause	Corrective Measures
According to the background monitoring device, some devices in the PV array are abnormally disconnected.	1. RS485 cable is abnormal.	1. Measure the voltage between RS485–A and RS485–B with a multimeter, and check whether the voltage is about 5V.
	2. There are repeated device addresses in the PV array.	2. Check whether there are repeated device addresses.

Fault	Possible Cause	Corrective Measures
According to the background monitoring device, some devices in the PV array are unstably connected.	3. Parameters of Logger3000 are incorrectly configured.	3. Check, through the WEB interface " System " -> " Port Parameter " -> " RS485 ", whether the PLC access is enabled.
	4. Master and slave node modules of the MPLC are abnormal.	4. Check whether the indicator D12 keeps steady red while the indicator D8 flickers green. If not, the modules are abnormal.
	5. Other causes	If the fault persists, please contact SUNGROW.
	1. There are repeated device addresses in the PV array.	1. Check whether there are repeated device addresses.
	2. Parameters of Logger3000 are incorrectly configured.	2. Check, through the WEB interface " System " -> " Port Parameter " -> " RS485 ", whether the PLC access is enabled.
	3. Other causes	If the fault persists, please contact SUNGROW.

6.3 PID Module Replacement (Optional)

Prerequisites

- Make sure the device is unavailable.
- Confirm that there is a spare PID module, the model is matched, and it can work normally.
- Professional and technical personnel must wear protective equipment that meets safety regulations when maintaining and replacing the device.
- Tools used during maintenance must be covered with an insulating protective layer.
- Before maintaining and replacing the device, make sure that the AC circuit breaker of the PID module is disconnected.

For an intelligent sub-array controller with a PID module, first, disconnect the power switch in the box-type substation corresponding to FU1 (800Vac), and then disconnect Q1(220Vac).

Steps

- step 1 Open the EMU200A cabinet door referring to "[4.5 Preparation Before Connection](#)".
- step 2 Loosen the nut of the "INPUT-OUTPUT" waterproof terminal at the bottom of the device referring to "[4.6.7 PID Dry Contact Connection \(Optional\)](#)".

step 3 Open the maintenance door of the device with a Phillips screwdriver referring to "4.6.7 PID Dry Contact Connection (Optional)".

step 4 Remove cables of the faulty PID module.

step 5 Unscrew the four fixing screws up and down the PID holder, and then remove the faulty PID module.

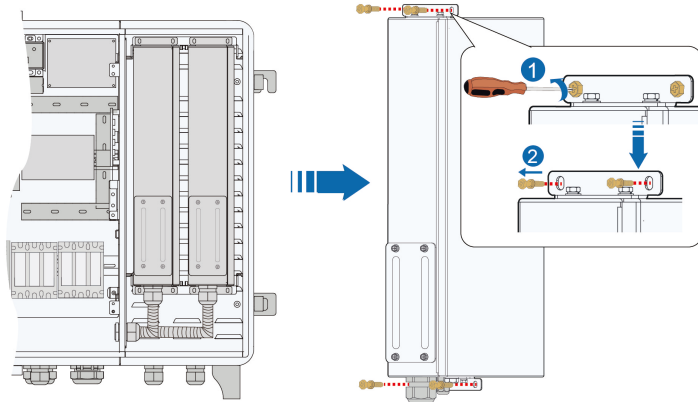

step 6 Install a new PID module.

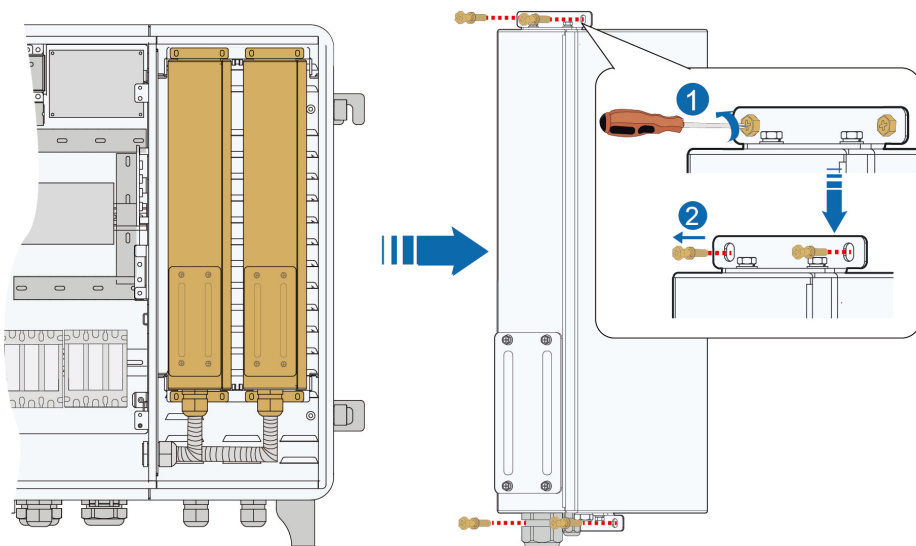

step 7 (Optional) To replace the PID module on the right, use a slotted screwdriver to flip the DIP switch of the PID module to "ON".

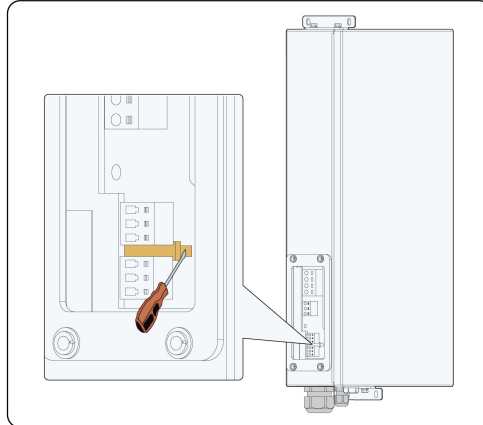

step 8 Connect the removed cables to the PID module.

step 9 Tighten the nut on the waterproof terminal.

step 10 Reinstall the maintenance door with the M4 screws with a tightening torque of 1.2N/m.

step 11 Adjust the limit rod and close the EMU200A cabinet door when the PID module works normally.

-- End

Web Operations

- 1 Delete the original faulty PID module through "Device"-> "Device List" on the Web page.
- 2 Add the new PID module and set relevant parameters.

7 Appendix A: Technical Parameters

Communication	
Max. number of devices	300
RS485 interface	5
MPLC Interface	2
Fiber port	2*100 / 1000Mbps
Ethernet port	4*10 / 100Mbps
Fast dispatch port (ETH)	1*10 / 100Mbps
PID & ISO Control Box	2
Fiber Switch (optional)	2 Fiber ports and 6 Ethernet ports
Fiber Splice Box (optional)	4-Input and 24-Output ST Single mode
SFP Module (optional)	100 / 1000Mbps
I/O Module (optional)	4-DI, 2-PT100, 2-AI (0 – 10 V), 2-DO
MPLC communication	
Max. communication distance	≤ 1000 m
Max. number of each channel devices	≤ 80inverters
Rated voltage	400 – 800 Vac
Max. withstands voltage	≤ 1000 Vac
Power supply	
AC input	100 – 277 Vac, 50 / 60 Hz
Power consumption	max. 900 W
Ambient conditions	
Operating Temperature	-30 °C – +60 °C
Storage Temperature	-40 °C – +70 °C
Relative air humidity	≤95 % (non-condensing)
Elevation	≤ 4000 m
Protection class	IP65
Mechanical parameters	
Dimensions (W x H x D)	860×680×275mm (±5mm)
Weight	36kg
Mounting type	Wall mounting, bracket mounting, and ground mounting
Cable in and out mode	Bottom in, bottom out

8 Appendix B: General Information

8.1 Quality Assurance

When product faults occur during the warranty period, SUNGROW will provide free service or replace the product with a new one.

Evidence

During the warranty period, the customer shall provide the product purchase invoice and date. In addition, the trademark on the product shall be undamaged and legible. Otherwise, SUNGROW has the right to refuse to honor the quality guarantee.

Conditions

- After replacement, unqualified products shall be processed by SUNGROW.
- The customer shall give SUNGROW a reasonable period to repair the faulty device.

Exclusion of Liability

In the following circumstances, SUNGROW has the right to refuse to honor the quality guarantee:

- The free warranty period for the whole machine/components has expired.
- The device is damaged during transport.
- The device is incorrectly installed, refitted, or used.
- The device operates in harsh conditions beyond those described in this manual.
- The fault or damage is caused by installation, repairs, modification, or disassembly performed by a service provider or personnel not from SUNGROW.
- The fault or damage is caused by the use of non-standard or non-SUNGROW components or software.
- The installation and use range are beyond stipulations of relevant international standards.
- The damage is caused by unexpected natural factors.

For faulty products in any of above cases, if the customer requests maintenance, paid maintenance service may be provided based on the judgment of SUNGROW.

8.2 Contact Information

In case of questions about this product, please contact us.

We need the following information to provide you the best assistance:

- Model of the device

- Serial number of the device
- Fault code/name
- Brief description of the problem

For detailed contact information, please visit: <https://en.sungrowpower.com/contactUS>

