

User Manual

Communication Box

COM100A



All Rights Reserved

All Rights Reserved

No part of this document can be reproduced in any form or by any means without the prior written permission of Sungrow Power Supply Co., Ltd (hereinafter "SUNGROW").

Trademarks

SUNGROW and other Sungrow trademarks used in this manual are owned by SUNGROW.

All other trademarks or registered trademarks mentioned in this manual are owned by their respective owners.

Software Licenses

- It is prohibited to use data contained in firmware or software developed by SUNGROW, in part or in full, for commercial purposes by any means.
- It is prohibited to perform reverse engineering, cracking, or any other operations that compromise the original program design of the software developed by SUNGROW.

About This Manual

This manual gives instructions mainly on the transport, storage, installation, electrical connection, and regular maintenance of the product, yet not all-encompassing regarding all details. You may visit [www. sungrowpower. com](http://www.sungrowpower.com) or the website of the equipment manufacturer for more information.

Declaration

To ensure safe use of the product, please read through the below information carefully:

- 1 This manual is intended for personnel who are responsible for product installation or other work on the product. Users must have certain electrical and mechanical expertise, and be familiar with the electrical and mechanical schematics and the characteristics of electronic components. SUNGROW shall not be held liable for any personal injury or economic loss arising from the installation carried out by non-qualified personnel or not in compliance with the safety instructions specified in this manual.
- 2 All pictures, marks, and symbols in this manual are owned by SUNGROW. No part of this manual may be reproduced by any non-internal staff without the prior written authorization of SUNGROW.
- 3 The manual may be updated and revised from time to time, however, there still might be slight deviation from the real product or errors. In such cases, the actual product you have purchased should take precedence. You can find the latest version of user manual on the company's website, or reach your sales for it.
- 4 To ensure the safety of the installation personnel, the product, and the system, be sure to follow the safety instructions specified in this manual when installing the product. SUNGROW shall not be held liable for any personal injury or economic loss arising from failure to follow the instructions specified in this manual.
- 5 If maintenance on or alteration to this product is needed, please contact SUNGROW customer service in advance. The copyright of this user manual belongs to SUNGROW, and any rights not expressly granted are reserved. The content herein is subject to change without notice and may deviate from the actual up-to-date product.

Target Group

This manual is intended for qualified technical persons who are responsible for installation, electrical connection, and other relevant work on the product.

Installation can only be done by qualified technical persons. Qualified technical persons must:

- Have certain electrical wiring, electronic, and mechanical expertise, and be familiar with electrical and mechanical schematics;
- Have received professional training in the installation and commissioning of electrical equipment;
- Be able to respond quickly to dangers or emergencies that may occur during the process of installation and commissioning;

- Read through this manual carefully and have a good understanding of the relevant safety instructions;
- Be familiar with applicable local standards and relevant safety regulations on electrical systems.

How to Use This Manual

Read through this manual carefully before using the product, and keep it properly in an easy-to-reach place.

The manual may be updated and revised from time to time, however, there still might be slight deviation from the real product or errors. In such cases, the actual product you have purchased should take precedence. You can find the latest version of the manual at support.sungrowpower.com or reach your sales for it.

Symbols in the Manual

To ensure the safety of life and property for users when using the product and to improve the efficiency of product use, the manual provides relevant safety information, which are highlighted by the following symbols.

Symbols used in this manual are listed below. Please review carefully for better use of this manual.

DANGER

Indicates an imminently hazardous situation which, if not avoided, will result in death or serious injury.

WARNING

Indicates a moderately hazardous situation which, if not avoided, will result in death or serious injury.

CAUTION

Indicates a slightly hazardous situation which, if not avoided, may result in minor or moderate injury.

NOTICE

Indicates a potential hazard which, if not avoided, will result in device malfunction or property damage.



Indicates supplementary information, emphasis on specific points, or tips related to the use of the product that might help to solve your problems or save your time.

Contents

All Rights Reserved	I
About This Manual	II
1 Safety Instructions	1
1.1 Safety Signs on the Product	1
1.2 General Safety Instructions	2
1.3 Packaging, Transport, and Storage Safety	4
1.4 Installation Safety	5
1.5 Electrical Safety	7
1.6 Operation Safety	8
1.7 Maintenance Safety	8
1.8 Disposal Safety	10
2 Product Description	11
2.1 Function Description	11
2.2 Main Features	11
2.3 Dimensions	12
3 Mechanical Mounting	13
3.1 Installation Notices	13
3.2 Inspection before Installation	13
3.3 Location Requirements	14
3.4 Installation Method	14
3.4.1 Bracket Mounting	15
3.4.2 Wall Mounting	15
3.4.3 Ground Mounting	17
3.5 Set Communication Address(optional)	17
3.6 Installing IO Modules (Optional)	18
4 Electrical Connection	20
4.1 Electrical Connection Notices	20
4.2 Waterproof Terminal Description	21
4.3 Internal Structure	21
4.4 Preparation Before Connection	22
4.5 Connection Steps	24

4.5.1	Grounding	24
4.5.2	RS485 Communication Terminal Connection	26
4.5.3	Optical Fibre (Optional).....	27
4.5.4	100ac–277Vac Power Supply Connection	28
4.5.5	PLC Wiring	29
4.5.6	DI/DO Port Connection	37
4.6	Post-wiring Processing	38
4.7	Communication Methods	38
5	Commissioning	39
5.1	Operation Notices.....	39
5.2	Inspection before Commissioning	39
5.3	Commissioning Steps	39
6	Troubleshooting and Maintenance	41
6.1	Maintenance Notices	41
6.2	Troubleshooting	41
7	Appendix A: Technical Parameters	43
8	Appendix B: General Information	44
8.1	Quality Assurance	44
8.2	Contact Information	44

1 Safety Instructions

Be sure to read through this manual carefully before proceeding with the transport, storage, installation, operation, use, and maintenance of the device. All work should be done by strictly following the safety instructions mentioned in this manual to ensure the personnel safety. Improper use or misoperation may result in:

- Injury to or death of the operator or other people;
- Damage to the device or the property of the operator or other people.





- Safety instructions in this manual should only serve as a supplement and not all-encompassing regarding all the norms that need to be followed. All work should be carried out considering the actual situation on the site.
- SUNGROW shall not be held liable for damages caused by violation of safe operation requirements, general safety standards, and safety instructions in this manual.

1.1 Safety Signs on the Product



Signs on the Product

Observe all warning signs on the product at all times, which are:

Symbol	Description
	High voltage inside. Risk of electrical shock hazard when it is touched.
	PE (Protective Earthing) terminal, which should be grounded properly to ensure the safety of operators.

Labels Inside the Product

Observe all labels inside the product at all times, which are:

Symbol	Description
	Warning Electric Shock.
	Must wear insulated protection supplies.

1.2 General Safety Instructions

Compliance with Laws and Regulations

NOTICE

All work, including transport, storage, installation, operation, use, and maintenance, should be done in compliance with the local laws, regulations, standards, and specifications.

Personnel Requirements

NOTICE

Persons who perform operations on the device must meet the following requirements:

- Have received professional training in the installation and commissioning of electrical equipment, and have the necessary experience;
- Be able to respond quickly to dangers or emergencies that may occur during the process of installation and commissioning;
- Persons, who are responsible for device installation and maintenance, must be trained thoroughly and have a firm grasp of the correct operation methods and a good knowledge of safety precautions and applicable local standards of the country/region;
- Persons responsible for special types of work (e.g. electrical operations, working at heights) must have relevant qualifications as required by the local regulations of the country/region.

DANGER

- Do not wear any conductive object, such as watches, bracelets, bangles, rings, and necklaces, during the operation process, so as to avoid electrical burns.
- Do not smoke in the area where the device is located, so as to prevent fires, electric shocks, and explosions, which may result in personal injuries or property damages.

DANGER

Use specialized insulated tools during operation to avoid electric shock hazards or short circuits. The tools should have an insulation withstand voltage rating that meets the requirements of the applicable local laws, regulations, standards, and specifications.

⚠ WARNING

Wear specialized personal protective equipment during the process of operation, such as protective clothing, insulated shoes, goggles, safety helmets, and safety gloves.

⚠ WARNING

Personnel except for those who perform operations on the device should stay away from the device.

Tools Requirements**⚠ WARNING**

- Ensure all necessary tools are ready, without any damage, and pass the inspection by a specialized agency. Do not use tools that have signs of damages or fail to pass the inspection. Make sure the tools are firm and secure.
- Understand how to use the tools correctly before starting using them to avoid personal injury or damage to the device.

⚠ WARNING

- Use a wooden or insulated ladder when working at heights to avoid getting an electric shock.
- Check if the ladder is in good shape and if its load capacity meets the requirements. Do not overload the ladder.

Environment Requirements**⚠ DANGER**

Do not place the device near heat or fire, so as to prevent damaging the device or causing fires.

⚠ DANGER

Do not store flammables and explosives in the device area. Do not place the device in an environment with flammable, explosive gas or smoke, or perform any operation in such environments.

⚠ WARNING

Do not install the device in an area close to liquids, so as to avoid device malfunction or short circuits caused by ingress of liquids.

⚠ WARNING

When installing the device, ensure the foundation is solid and stable and has a load-bearing capacity up to the requirements of the device.

⚠ WARNING

Do not perform any operation on the product (including but not limited to, handling, installing, powering on, and maintaining the product, performing electrical connection, and working at heights) in harsh weather conditions, such as thunder and lightning, rain, snow, and Level 6 or stronger winds.

⚠ WARNING

The device should be kept in a clean, dry, and well-ventilated place and protected from dust and condensation.

⚠ WARNING

Do not install the device in a place with strong vibration, strong noise source, or strong electromagnetic field interference.

⚠ CAUTION

To prevent irrelevant personnel from operating the product by mistake or other accidents, please set up highly visible warning signages or safety warning tapes around the product.

NOTICE

Ensure the safety signs, warning labels, and the nameplate of the device are clearly legible.

1.3 Packaging, Transport, and Storage Safety

Packaging

The product is packed in a cardboard box with orientation markings that provide loading and unloading instructions.

Transport

- All work related to transport must be carried out in compliance with the applicable local laws and regulations of the country/region.
- Measures should be taken to fasten the goods during transport, so as to avoid damages to product packaging due to strong shaking or bumping.

- Get prepared for carrying its weight before handling the device to avoid getting hurt. This device should be moved by at least 3 people together.

Storage

- The place where the product is stored should be kept dry, clean, and well-ventilated, protected from hazardous gases.
- Do not store the product in a place where corrosives are kept.
- The packaged product should be stored in an appropriate environment. See "Technical Data" for the corresponding environmental parameters.

Unpacking and Inspection

- Non-qualified personnel are forbidden from disassembling the device or moving its components.
- Check if the product you have received matches the order you placed.
- Inspect the product for external damages or damages to its structural parts.
- Check if the safety signs, warning labels, and the nameplate on the product are all legible.

In case of any problem with the above-mentioned inspection items, contact SUNGROW in time.

1.4 Installation Safety

DANGER

During installation, do not perform any operation on the device when it is powered on. Do not connect or disconnect the cables when the device is powered on, as electric arcs or sparks may occur immediately when the cable core is in contact with the conductor, which may cause fires or personal injuries.

NOTICE

Installation should be conducted in compliance with the applicable local laws, regulations, standards, and specifications.

Installation Requirements

WARNING

Poor operating environments will affect the device's system performance!

- **Install the product in a well-ventilated place.**
- **Ensure the product's heat dissipation system or air vent is not blocked.**
- **Do not install the product in an environment with flammables, explosives, or smoke.**

Pre-installation

NOTICE

- Upon receiving the product, be sure to inspect it for damages. Contact **SUN-GROW** or the transport company immediately in case of anything abnormal.
- Be sure to have a good understanding of the safety instructions in this manual before performing any operation on the product.
- Please load/unload, handle, install, operate, and maintain the device by referring to the descriptions in this manual to ensure the safe use of the device.
- Before installing the device, ensure the cabinet is stable and not tilted.

During Installation

NOTICE

This product can only be used for purposes specified in this manual. Unauthorized alternations or use of parts and components not sold or recommended by **SUN-GROW** may result in fires, electric shocks, and other hazards.

NOTICE

Disconnect all electrical connection and the upstream input switch before installation, and ensure the device is voltage-free.

NOTICE

If drilling is required during installation:

- Wear goggles and safety gloves.
- Avoid the water pipes and electrical wires inside the wall when drilling.
- Cover the product to protect it from ingress of debris and dust.

Post-installation

NOTICE

After the device is installed, clear away the empty packaging materials in the device area, such as the cardboard box, foam, plastics, and ties.

1.5 Electrical Safety

Improper wiring may result in personal injuries. Operators responsible for electrical wiring must read through the safety instructions carefully before proceeding with this work.

DANGER

Before carrying out electrical connection:

- **Make sure the product is not damaged; otherwise, it may lead to danger.**
- **Disconnect the upstream input switch and ensure the device is voltage-free; otherwise, it may lead to electric shocks.**

DANGER

Improper or incorrect electrical wiring may result in accidents such as fires or electric shocks.

DANGER

Danger to life due to high voltage inside the device!

- **When performing electrical wiring, operators must wear proper personal protective equipment and use specialized insulated tools, so as to avoid electric shock hazards or short circuits.**
- **Ensure the cables are voltage-free using a measurement instrument before touching them.**
- **Please observe the warning signs on the device, and perform operations by strictly following the corresponding safety instructions.**

WARNING

For the device that needs to be grounded, connect the PE cable as the first step when installing it, and disconnect the PE cable at the very end of the process when removing it.

WARNING

Before operating the device, inspect the electrical connection and ensure the device is reliably grounded.

WARNING

If the power cable is not long enough, replace it with a new one. Do not add joints or welding spots to the power cable.

⚠ WARNING

- **Electrical connection must be performed by qualified personnel.**
- **All work related to wiring must be conducted in compliance with the applicable local laws and regulations of the country/region.**
- **Please observe the warning signs on the device, and perform operations by strictly following the corresponding safety instructions.**
- **Damages to the product due to incorrect wiring will not be covered by the warranty.**

1.6 Operation Safety

There is high voltage inside the device when it is running, and improper operation may cause personal injuries or property damages. Please perform operations by strictly following the safety instructions specified in this manual and other relevant documentation.

⚠ DANGER

When laying cables, keep the cables at least 30 mm away from the outer edge of the heat-generating components or areas, so as to protect the insulation layer of cables from aging or getting damaged due to high temperature.

⚠ DANGER

When the device is running:

- **Do not touch any live component of the device; otherwise, it may lead to electrical shocks.**
- **Do not touch any wiring terminal on the device; otherwise, it may lead to electrical shocks.**
- **Do not touch any hot part of the device (e.g. heat sink); otherwise, it may cause burns.**

1.7 Maintenance Safety

Improper maintenance may lead to personal injuries or property damages. Therefore, it is necessary to power off the device before maintenance and perform operations by strictly following the safety instructions specified in this manual and other relevant documentation.

⚠ DANGER

- **Before maintenance, disconnect the upstream power supply and PLC power supply first; otherwise, it may cause personal injury.**
- **Wait 25 minutes after the device is powered off, then measure the voltage and current with a specialized measurement instrument. Only when no current or voltage is present, operators, who wear protective equipment, can perform operation and maintenance on the device.**
- **Even if the device is shut down, it may still be very hot and cause burns. Please perform operations on the device wearing safety gloves after it cools down.**

⚠ DANGER

Do not touch the grid or the contacts and terminals inside the product that are connected to the grid; otherwise, it may lead to electric shocks.

⚠ WARNING

Power off the device before proceeding with maintenance.

⚠ WARNING

- **Repair of the device can only be performed by SUNGROW's service team or qualified personnel.**
- **Users are forbidden from performing repair and maintenance or replacing modules by themselves. Otherwise, it may cause severe personal injuries or property damages.**

⚠ CAUTION

To prevent irrelevant personnel from operating the product by mistake or other accidents, please set up highly visible warning signages or safety warning tapes around the product.

NOTICE

- **Do not use cleaning agents to clean up the device. Otherwise, the device may be damaged, and losses caused therefrom will not be covered by the warranty.**
- **If the paint on device's enclosure peels off or the enclosure gets rusty, repair it in time. Otherwise, the device performance may be affected.**
- **No component inside the device requires maintenance. Do not open the device (except for the junction box) or replace any internal components without authorization. Otherwise, damages caused therefrom will not be covered by the warranty.**
- **To minimize the risk of electric shocks, do not perform maintenance operations that are not specified in this manual. If needed, please contact SUNGROW for maintenance and repair services. Otherwise, damages caused therefrom will not be covered by the warranty.**

1.8 Disposal Safety

Please scrap the product in accordance with relevant local regulations and standards to avoid property damages or personal injuries.

NOTICE

- **All work related to product scrapping must be done in compliance with the applicable local laws and regulations of the country/region.**
- **Ensure the safety signs, warning labels, and the nameplate on the product are all legible before scrapping it.**

2 Product Description

2.1 Function Description

The system block diagram is shown in the following figure.

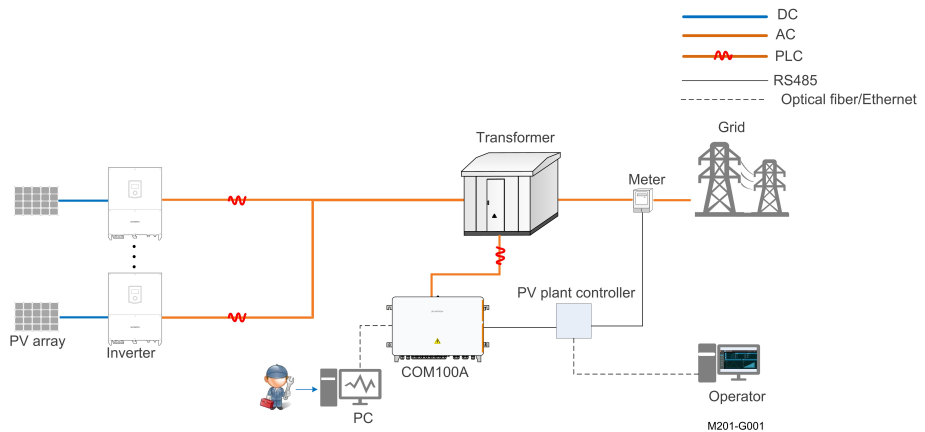

2.2 Main Features

Smart and flexible

- Integrating data collector, support of local intelligent commissioning
- Wall mounting available, flexible installation

Simple and efficient

- Seamless connection to iSolarCloud, easy management of PV devices
- Built-in PLC communication, communication and management of string inverters developed by SUNGROW without cable routing

Safe and reliable

- Equipped with SPD protection, steady and reliable operation
- Ingress of protection IP65, long-term reliable outdoor operation

2.3 Dimensions

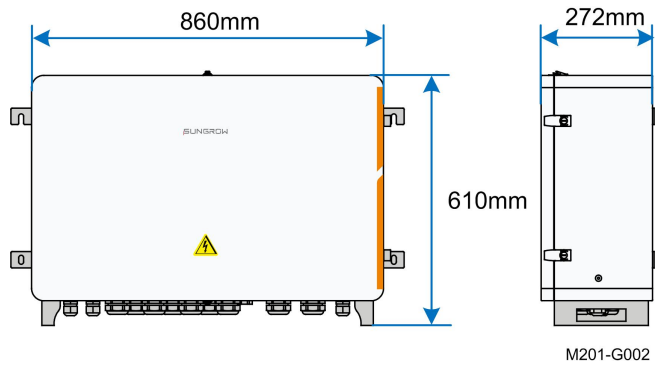

3 Mechanical Mounting

3.1 Installation Notices

Before installing the device, read through the “General Safety Instructions” first and ensure the requirements listed therein, as well as requirements mentioned in "Installation Safety", are all met.

DANGER

During installation, do not perform any operation on the device when it is powered on. Do not connect or disconnect the cables when the device is powered on, as electric arcs or sparks may occur immediately when the cable core is in contact with the conductor, which may cause fires or personal injuries.

WARNING

- **Install the product in a well-ventilated place.**
- **Ensure the product’s heat dissipation system or air vent is not blocked.**

NOTICE

Disconnect all electrical connection and the upstream input switch before installation, and ensure the device is voltage-free.

NOTICE

If drilling is required during installation:

- **Wear goggles and safety gloves.**
- **Avoid the water pipes and electrical wires inside the wall when drilling.**
- **Cover the product to protect it from ingress of debris and dust.**

3.2 Inspection before Installation

Check the scope of delivery for completeness according to the packing list. The following items should be included:

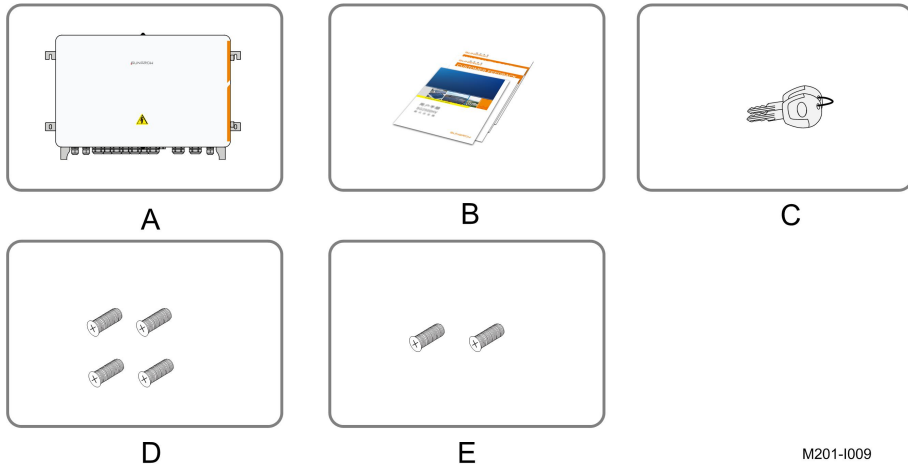

M201-1009

Item	Description	Sum
A	COM100A	1
B	Documents, including certificate, warranty card, delivery inspection report, user manual, etc.	1
C	Keys	1
D	M10x45 bolt assembly	4
E	M6x14 bolt	1

NOTICE

The device is carefully tested and inspected before delivery, but damage may be caused during shipping. Therefore, inspect the device before installation. If there any damage, contact the forwarding company or SUNGROW.

3.3 Location Requirements

- With the ingress of protection IP65, COM100A can be installed outdoors.
- Ambient temperature: -30°C to +60°C , and ambient humidity: 5%–95%。 Excessive moisture can damage internal components.
- Take anti-moisture and anti-corrosion measures.

3.4 Installation Method

⚠ WARNING

**Beware of the weight of the device throughout the installation process!
Tilting or falling of the device due to inappropriate processing can cause personal injury!**

The installation dimensions of mounting ears on the back of the device are shown in the following figure.

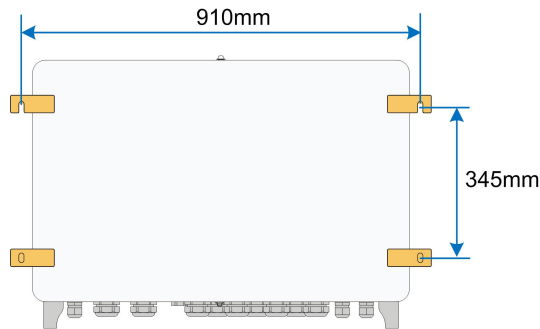

M201-I002

3.4.1 Bracket Mounting

step 1 Mark the hole locations on the mounting brackets according to the installation dimensions of mounting ears and drill holes on the marked locations according to bolt specifications.

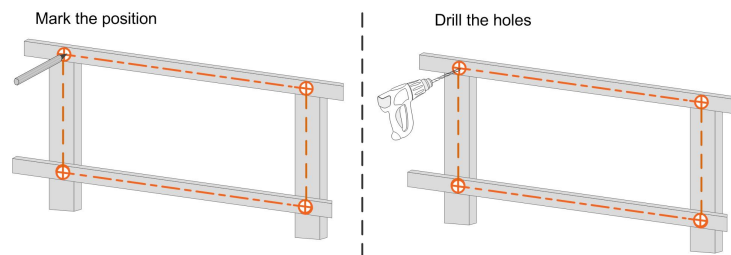

M201-I013

step 2 Fasten the device on the brackets in the order of M10x45 bolt, mounting ear, mounting bracket, and nut with a fastening torque of $37 \pm 3 \text{N.m}$.

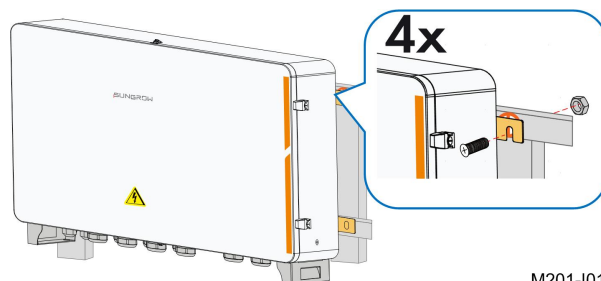

M201-I014

step 3 Check to ensure the device is firmly in place.

-- End

3.4.2 Wall Mounting

step 1 Mark the hole locations on the installation wall according to the foregoing installation dimensions.

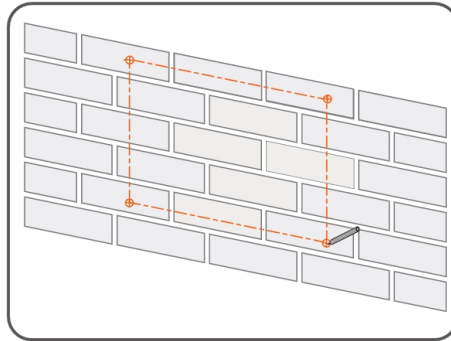

step 2 Drill holes on the marked locations.

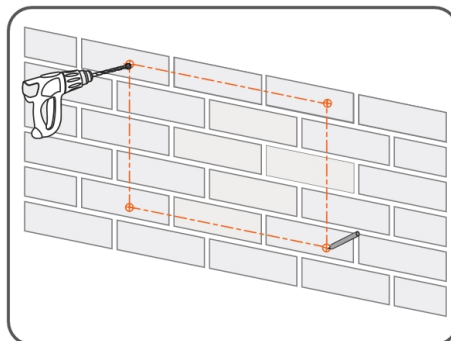

step 3 Place the M10x80 expansion sleeve(not included in the scope of delivery) into the hole, and tap it with a rubber hammer. Make it completely embedded in the wall.

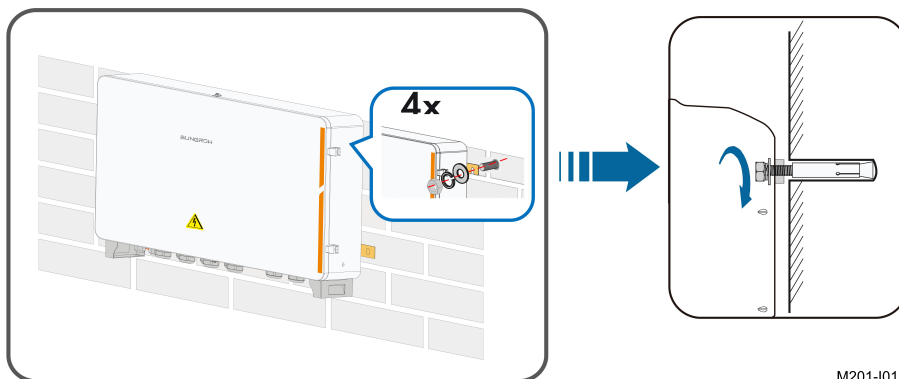

M201-I012



The length of the expansion solenoid should be selected reasonably in accordance with the drilling depth.

step 4 Fasten the device on the wall in the order of nut, lock washer, flat washer, mounting ear, and expansion sleeve with a fastening torque of $37\pm 3\text{N.m}$.

-- End

3.4.3 Ground Mounting

For the ground mounting, the device is fixed to the foundation via the installation holes in the bottom of the device (shown in Figure A below).

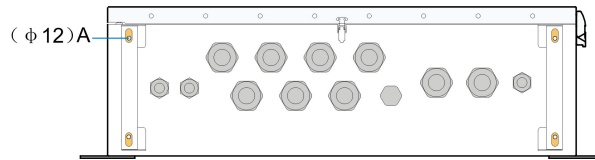

M201-I015

step 1 Construct the foundation according to the exterior dimensions of the device.

step 2 Pre-embed the foundation bolts in the four corners of the foundation, and the bolts used are M10.

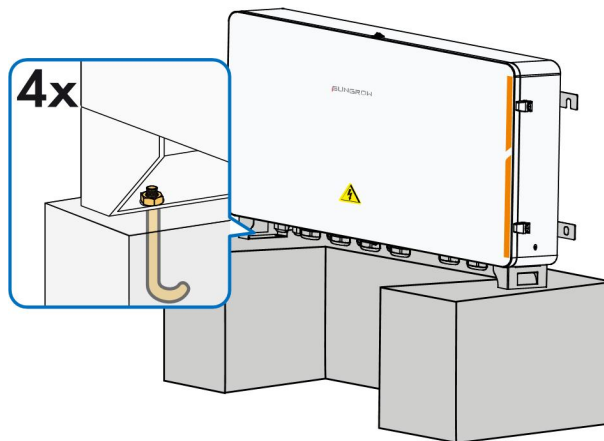

M201-I016

step 3 Secure the installation holes in bottom of the device to the foundation with a fastening torque of $37\pm 3\text{N.m}$.

-- End

3.5 Set Communication Address(optional)

Take out the IO module, find the dip switch on the back, and set the communication address through the dip switch. The setting range of the communication address is from 1 to 15.

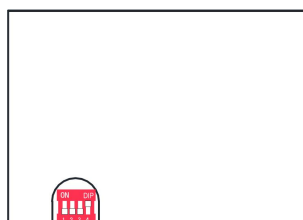

M201-I021

The DIP switches are from left to right from low position to high position.

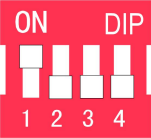
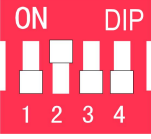
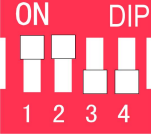
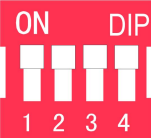
Example of communi- cation address setting	Binary address	Decimal address
	0001	1 ($1 \times 2^0 = 1$)
	0010	2 ($1 \times 2^1 + 0 \times 2^0 = 2$)
	0011	3 ($1 \times 2^1 + 1 \times 2^0 = 3$)
⋮	⋮	⋮
	1111	$1 \times 2^3 + 1 \times 2^2 + 1 \times 2^1 + 1 \times 2^0 = 15$

NOTICE

The dip switch addresses on each IO module must be different.

3.6 Installing IO Modules (Optional)

This operation is required if IO modules are ordered.

step 1 Remove the IO modules and M4 screw assembly from the IO module deliverables.

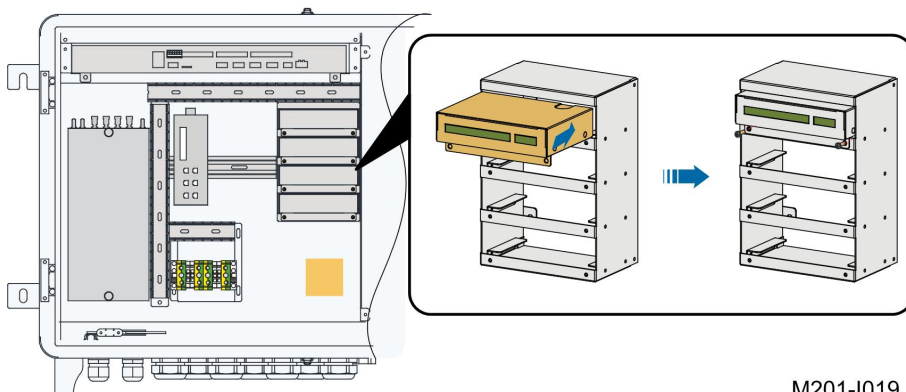

M201-I019

step 2 After inserting the IO modules into the reserved area, tighten them with M4 screw assembly with a tightening torque of 1.2N.m.

step 3 All four IO modules should be installed as shown in the following figure.



M201-I020

-- End

4 Electrical Connection

4.1 Electrical Connection Notices

Before performing electrical connection, read through the "General Safety Instructions" first and ensure the requirements listed therein, as well as requirements mentioned in "Electrical Safety", are all met.

DANGER

Before carrying out electrical connection:

- **Make sure the product is not damaged; otherwise, it may lead to danger.**
- **Disconnect the upstream input switch and ensure the device is voltage-free; otherwise, it may lead to electric shocks.**

DANGER

Danger to life due to high voltage inside the device!

- **When performing electrical wiring, operators must wear proper personal protective equipment and use specialized insulated tools, so as to avoid electric shock hazards or short circuits.**
- **Ensure the cables are voltage-free using a measurement instrument before touching them.**
- **Please observe the warning signs on the device, and perform operations by strictly following the corresponding safety instructions.**

WARNING

- **Electrical connection must be performed by qualified personnel.**
- **Please observe the warning signs on the device, and perform operations by strictly following the corresponding safety instructions.**

4.2 Waterproof Terminal Description

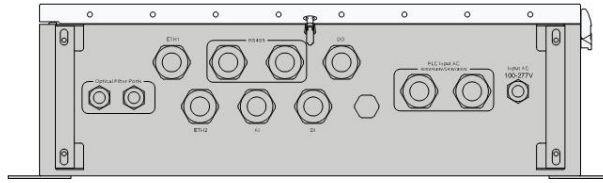

M201-E001

Mark	Description
ETH1	Waterproof terminals for Ethernet communication cables
ETH2	
RS485	Waterproof terminals for RS485 communication cables
AI	Waterproof terminals for analog input cables
DI	Waterproof terminals for dry contact input cables
PLC Input AC400V/480V/540V/800V	Waterproof terminal for PLC communication cables
Input AC100–277V	Waterproof terminal for AC 100–277V power cables
Optical fiber ports	Waterproof terminals for optical fibers
	Grounding waterproof terminal

4.3 Internal Structure

The internal structure of COM100A is shown in the following figure.

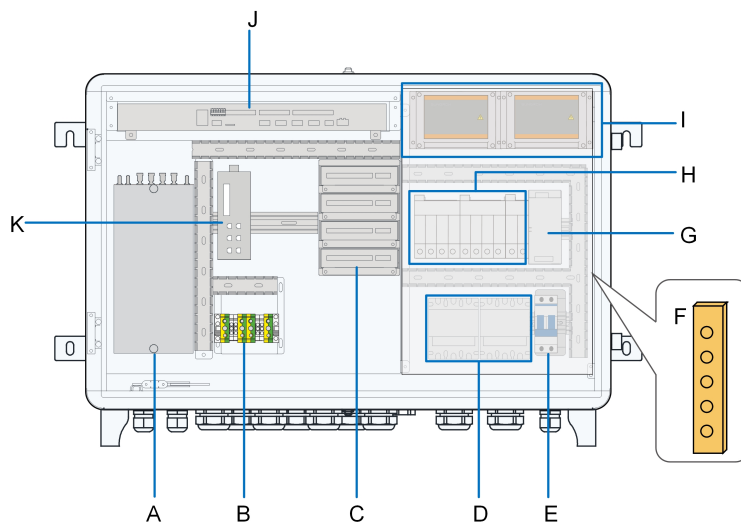

M201-E002

Internal components may differ as per selected product module. For details, refer to the product received.

No.	Description	Recommended Cable Specification	Source
A*	Splice box	—	—
B	RS485 communication terminal	2 x (0.75~1.5) mm ² outdoor ultraviolet protection STP	Beyond the scope of delivery
C*	IO module	0.75mm ²	Beyond the scope of delivery
D	Fuse	—	—
E	Circuit breaker	1~1.5 mm ² or 15~17AWG outdoor ultraviolet protection cable	Beyond the scope of delivery
F	Grounding copper bar	4mm ² ~ 10mm ² or 7 ~ 11AWG	Beyond the scope of delivery
G	Power module	1.5mm ² or 13AWG	Beyond the scope of delivery
H	Surge protective device	—	—
I	PLC module	—	—
J	Logger3000	—	—
K*	Switch	—	—

* is optional.

4.4 Preparation Before Connection

step 1 Open the cabinet. Unlock the door with the specific key, as shown in the following figure.

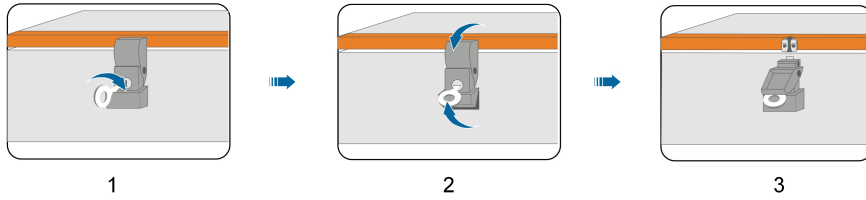

step 2 Unclip the top and bottom clips of the cabinet.

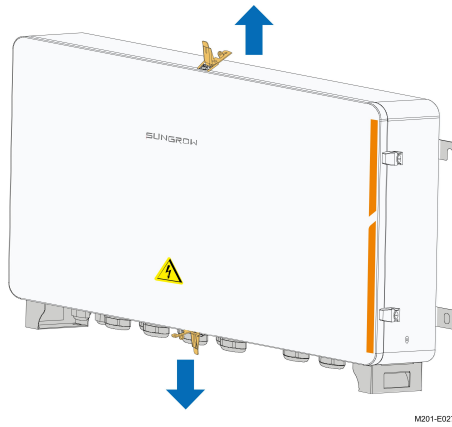

step 3 Remove the protective cover inside the cabinet.

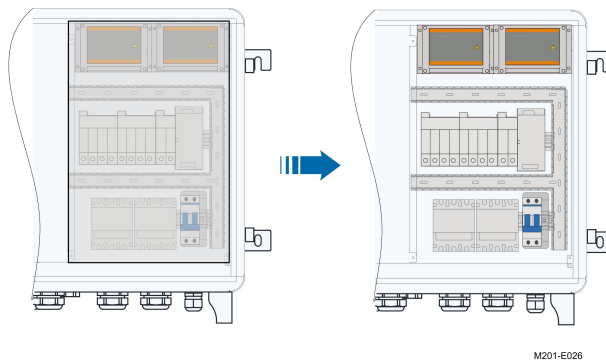

step 4 Disconnect the upstream input switch of the device, and turn the power switch inside the device to the "OFF" position to ensure the device is voltage-free.



step 5 Disconnect the switch of the transformer side.

-- End

4.5 Connection Steps

4.5.1 Grounding

Safety Instructions

⚠ WARNING

The grounding cable must be grounded reliably! Otherwise,

- Lethal electrical shock can be caused when fault occurs!
- The device may be damaged by lightning!

Brief Introduction

The device is designed with two grounding terminals: grounding copper bar inside the cabinet and external PE point.

On site, connect both grounding terminals reliably.

Preparation before Installation

- Prepare the grounding cable.
- Strip the cable and crimp the OT terminal, and then use heat shrink tubing to tighten the cable and the OT terminal.

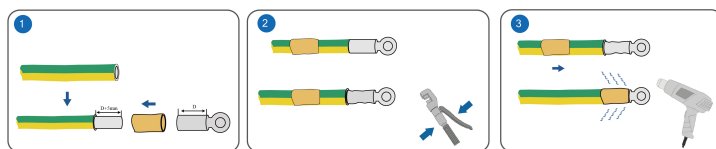

4.5.1.1 Copper Bar Grounding

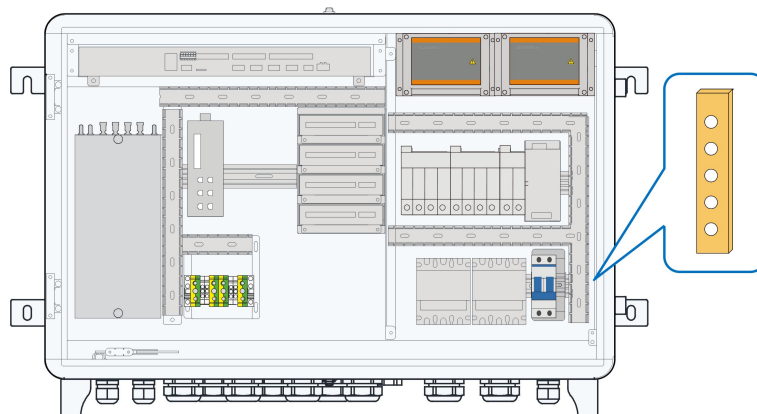

Position Description

The grounding copper bar is located inside the cabinet, as shown in the figure below.



M201-E005

Wiring Steps

- step 1 Unscrew the waterproof terminal “” at the bottom of the device.
- step 2 Connect the yellow-green grounding cable led from outside to the grounding copper bar inside the device through the internal waterproof terminal “”.

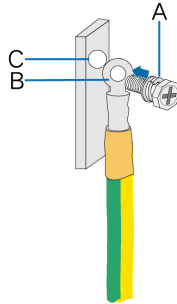

No.	Definition
A	M6x12 bolt(Beyond the scope of delivery)
B	OT terminal
C	Grounding hole

- step 3 Secure the cable with M6x12 bolt with a fastening torque of $7.5 \pm 0.5 \text{ N} \cdot \text{m}$.
- step 4 Screw the waterproof terminal at the bottom of the device.

-- End

4.5.1.2 PE Point Grounding

Position Description

The external PE point of the device is shown by A in the figure below.

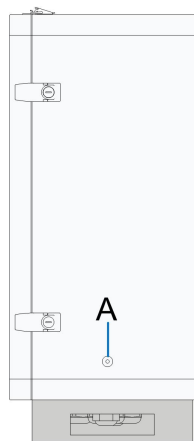

M201-E007

Wiring Steps

Anchor the prepared OT terminal to the grounding hole with bolt assembly with a fastening torque of $7.5 \pm 0.5 \text{ N} \cdot \text{m}$.

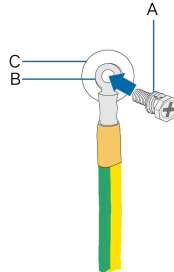

No.	Definition
A	M6 x 14 bolt assembly(included in the scope of delivery)
B	OT terminal
C	Grounding hole

4.5.2 RS485 Communication Terminal Connection

Preparation Before Connection

NOTICE

When the COM100A is connected to external devices by RS485, make sure that the external devices are protected against lightning.

Cable Requirements

Cables connected to the device must be $2 \times (0.75 \sim 1.5) \text{ mm}^2$ in cross-sectional area.

Wiring Steps

- step 1 Unscrew the "RS485" waterproof terminal at the bottom of the device.
- step 2 Connect the RS485 cable led from outside to the communication terminal inside the device through the "RS485" waterproof terminal.
- step 3 Strip the cable jacket with a wire stripper.

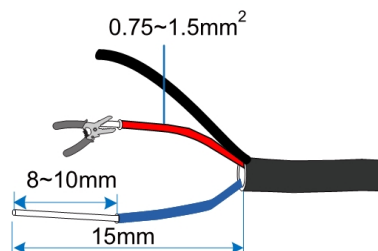

- step 4 Connect the cable to the corresponding terminal, and secure it with a screwdriver with a fastening torque between 0.5N·m and 0.6N·m.

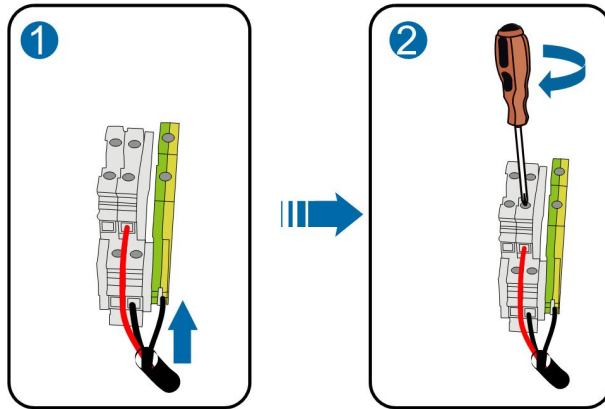

Mark	Definition
A	Connected to RS485–A, corresponding to upper-layer terminal
B	Connected to RS485–B, corresponding to lower-layer terminal
GND	Connected to RS485 cable shield

- step 5 Gently pull the cable backwards to ensure firm connection.
- step 6 Screw the "RS485" waterproof terminal at the bottom of the device.

-- End

4.5.3 Optical Fibre (Optional)

Preparation before Installation

Before installation, prepare the required components. Components listed below are for reference only, and the actual situation may differ.

No.	Component
1	Pigtail: single-mode ST
2	Jumper: Single-mode single-core ST-SC, 500mm
3	ST flange
4	Network cable, 460mm

Installation Steps

- step 1 Unscrew the waterproof terminal "Optical fiber ports", and lead the optical fibre through the terminal.
- step 2 Splice the optical fibre inside the splice box.



For details, contact SUNGROW.

- step 3 Screw the waterproof terminal "Optical fiber ports".

-- End

4.5.4 100ac–277Vac Power Supply Connection

Preparation before Installation

- Before wiring power supply, ensure that the micro circuit breaker is in the OFF position.
- Prepare the AC cable.

Installation Steps

step 1 Unscrew the waterproof terminal "Input AC 100–277", and lead the external power supply cable through the terminal.

step 2 Strip the cable with a wire stripper.

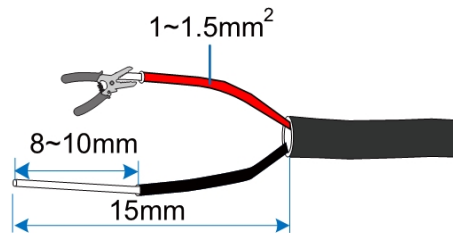

step 3 Crimp the cord end terminal.

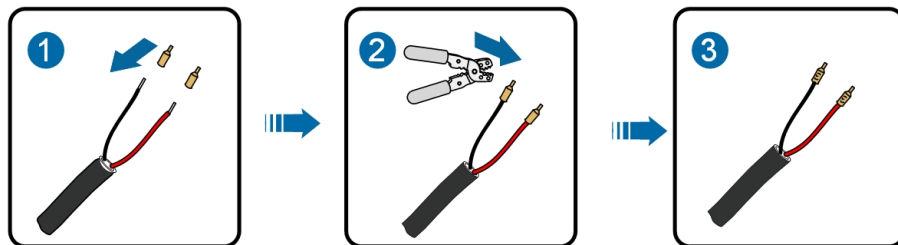

step 4 Connect the cord end terminal to the corresponding terminal, and secure it with a screw with a fastening torque of 2.0N·m.

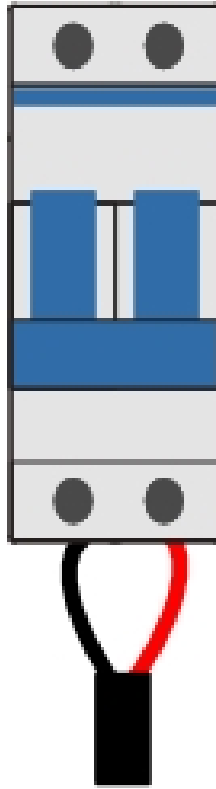

step 5 Screw the waterproof terminal "Input AC 100–277".

-- End

4.5.5 PLC Wiring

This section gives an introduction to PLC wiring diagrams and rules for PLC wiring between different devices.

4.5.5.1 Application Scenarios

PLC is applied mainly to the double-winding transformer and the double-split transformer. Wiring diagrams under these two application scenarios are shown as follows.

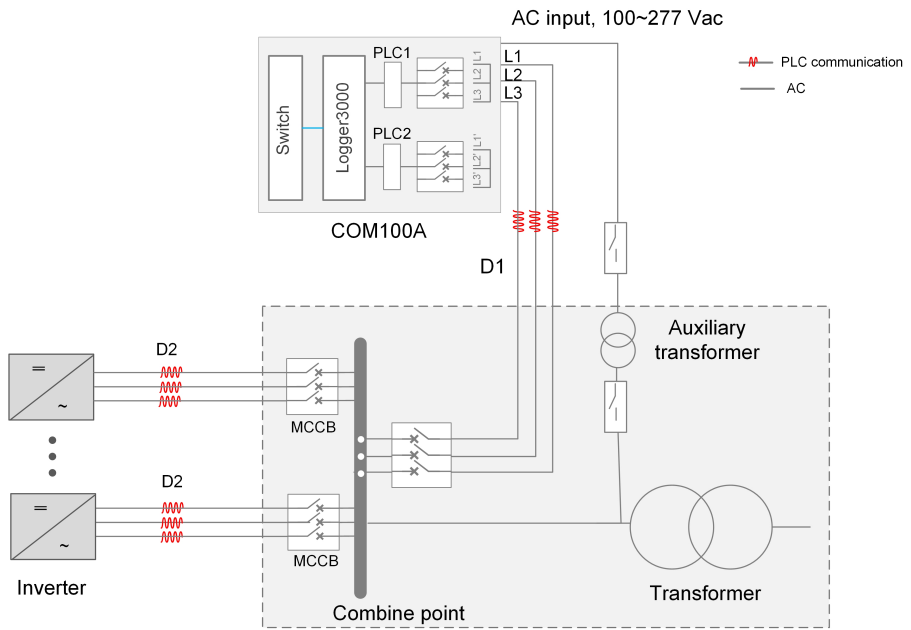

figure 4-1 PLC wiring diagram for a double-winding transformer

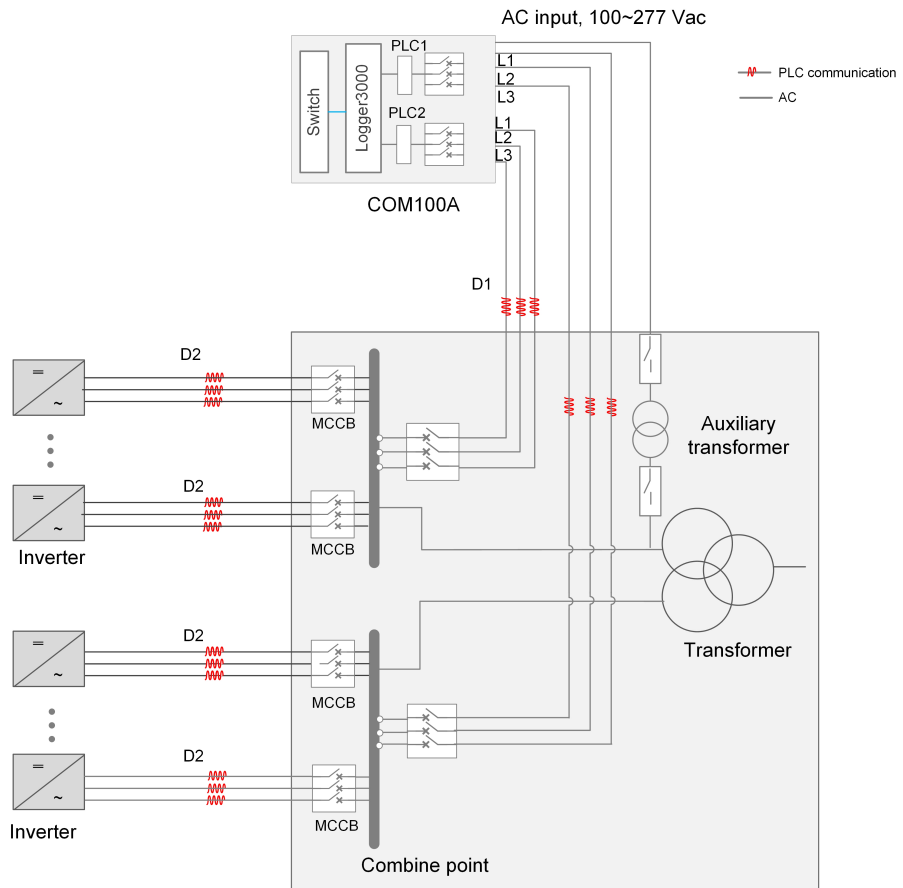



figure 4-2 PLC wiring diagram for a double-split transformer

Description of parameters in the diagrams is listed in the table below.

Parameter	Description	Cable Specification	Remarks
D1	Length of PLC communication box to box-type transformer	<ul style="list-style-type: none"> Use outdoor UV-resistant multi-core copper AC cable with a core diameter of $\geq 2.5\text{mm}^2$. Cable isolation voltage $> 1000\text{V}$. Suggested length $< 10\text{m}$. Shorter cable leads to better communication. 	$D1 + D2 \leq 1000\text{m}$

Parameter	Description	Cable Specification	Remarks
D2	Length of PLC cable from box-type transformer to inverter	<ul style="list-style-type: none"> Length $\leq 990\text{m}$, if a multi-core AC cable is used. Length $\leq 790\text{m}$, if a single-core AC cable is used. The cable should be fastened every 1 meter, as shown in the figure below. 	
			
	Port input voltage	800 Vac	-
PLC module	Port supply voltage	24 Vdc	-
	Maximum number of inverters connected	80	-

4.5.5.2 PLC Wiring Rules

Rules for PLC wiring from box-type transformer to inverter

AC cables between the box-type transformer and the inverters can be laid in cable ducts, cable trenches, or pipelines. In addition, AC cable laying should be performed in compliance with requirements for PLC wiring under the same box-type transformer, as well as those for PLC wiring under different box-type transformers.

- Requirements for PLC wiring under the same box-type transformer
 - Only AC cables under the same box-type transformer can be laid in the cable trench. Diagram of PLC wiring under the same box-type transformer is shown below.

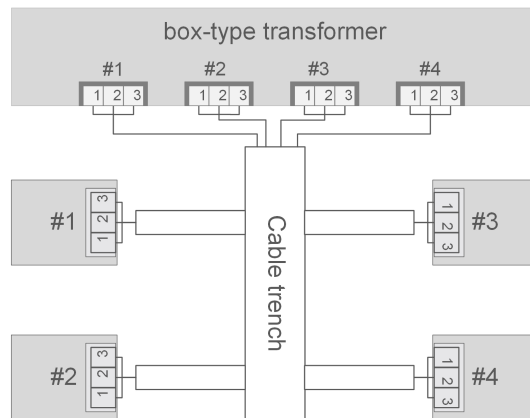

figure 4-3 Diagram of PLC wiring under the same box-type transformer

- 2 Cables can be laid in the cable trench in parallel, which however should not get entangled or knotted. There is no requirement for spacing between AC cables in the same trench.

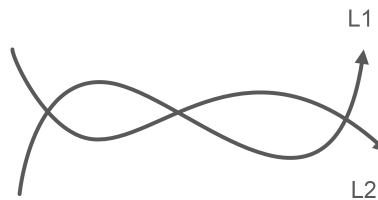

figure 4-4 Knotted PLC cable

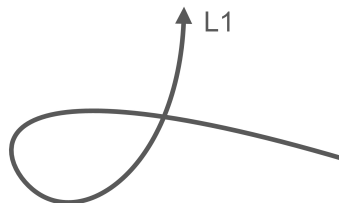

figure 4-5 Entangled PLC cable

- 3 If single-core cables are adopted, AC cables of the inverters should be fastened every 1 meter with cable ties. In addition, cables between different inverters should be laid in parallel without getting entangled or knotted.
- 4 Requirements for spacing between LV AC cable and MV AC cable of the same box-type transformer are listed as follows.
 - In the case of two cables laid parallel to each other, the horizontal spacing between them should be >3m.

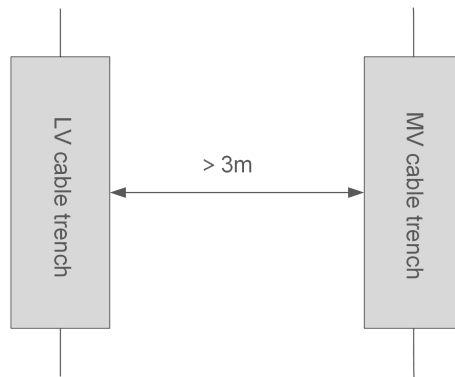

figure 4-6 Horizontal spacing between PLC cables (in parallel)

- In the case of two cables laid crosswise, the angle formed should fall in the range of 60°-120° and the vertical spacing between them should be >1m.

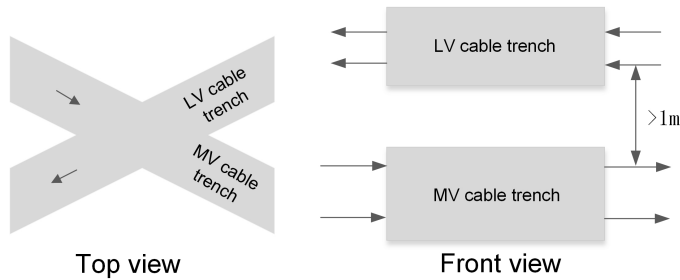

figure 4-7 Vertical spacing between PLC cables (crosswise)

- Requirements for PLC wiring under different box-type transformers
 - 1 LV-side AC cables of different box-type transformers should be laid in their own cable trenches. Diagram of PLC wiring under different box-type transformers is shown below.

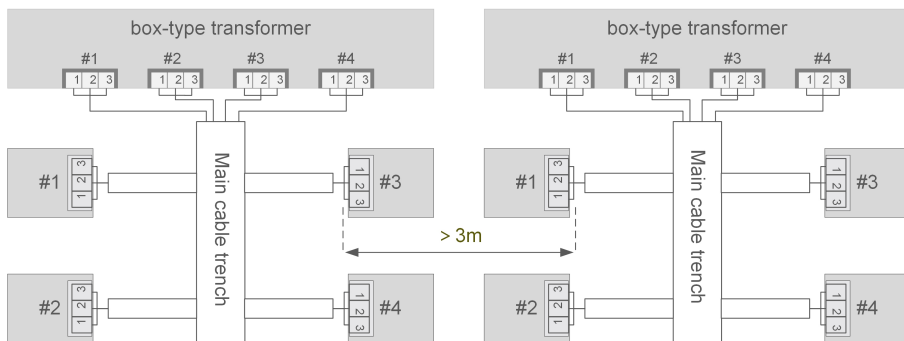

figure 4-8 Diagram of PLC wiring under different box-type transformers

- 2 Requirements for spacing between LV-side cable trays of different box-type transformers are listed as follows.
 - In the case of two cables laid parallel to each other, the horizontal spacing between them should be >3m.

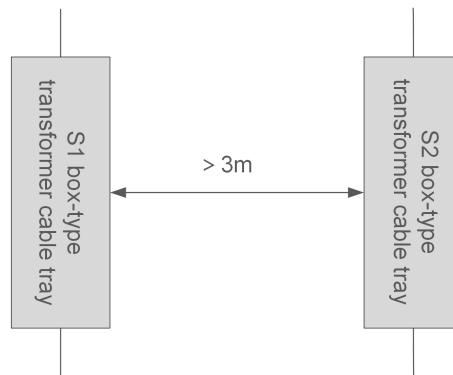

figure 4-9 Horizontal spacing between PLC cables (in parallel)

- In the case of two cables laid crosswise, the angle formed should fall in the range of 60° - 120° and the vertical spacing between them should be $>1\text{m}$.

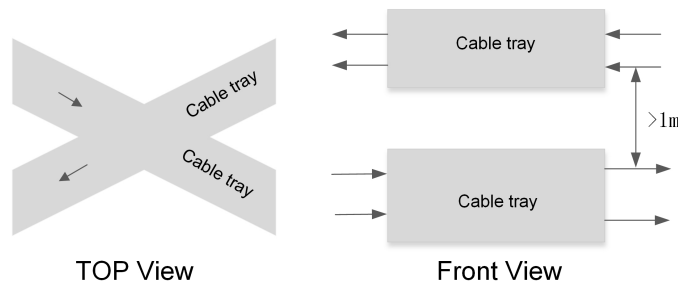

figure 4-10 Vertical spacing between PLC cables (crosswise)

- 3 Wiring requirements of MV AC cable and LV AC cable of different box-type transformers are listed as follows.
 - In the case of two cables laid parallel to each other, the horizontal spacing between them should be $>3\text{m}$.
 - In the case of two cables laid crosswise, the angle formed should fall in the range of 60° - 120° and the vertical spacing between them should be $>1\text{m}$.

Rules for PLC wiring from communication box to box-type transformer

- 1 AC cables from communication box to box-type transformer should be laid parallel to each other, without getting knotted or entangled in the cable trench.
- 2 The coupling point for connecting the PLC cable to the box-type transformer busbar is recommended to be arranged in the position corresponding to the middle of the busbar. For instance, for an 8-branch busbar, the coupling point is suggested to be set corresponding to the 4th or 5th branch busbar; while for a 9-branch busbar, it is suggested to be set corresponding to the 5th branch busbar.
- 3 Use the multi-core copper AC cable with a core diameter of $\geq 2.5\text{mm}^2$.
- 4 Rated power-frequency voltage to ground of three-phase AC cable should be $\geq 1000\text{V}$. Cable length should be $< 10\text{m}$. Shorter cable leads to better communication.

4.5.5.3 PLC Wiring

Pre-wiring preparation

- Before performing AC wiring, please ensure that upstream AC switches and circuit breakers inside the device are all disconnected.
- Please refer to "4.5.5.1 Application Scenarios" for PLC application scenarios and cable specifications.
- Please refer to "4.5.5.2 PLC Wiring Rules" for wiring diagrams under different application scenarios.

Wiring

- 1 Unscrew the "Input AC 400V/480V/540V/800V" waterproof terminal at the bottom of the device, and lead the external AC cable through the waterproof terminal.
- 2 Remove the protective layer of the cable using a wire stripper to expose the copper core.

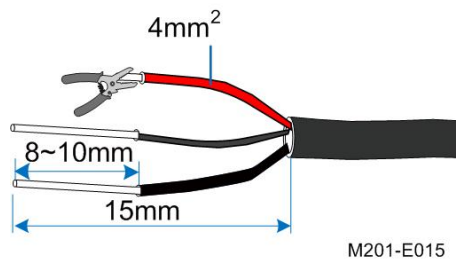

- 3 Crimp the OT terminal.

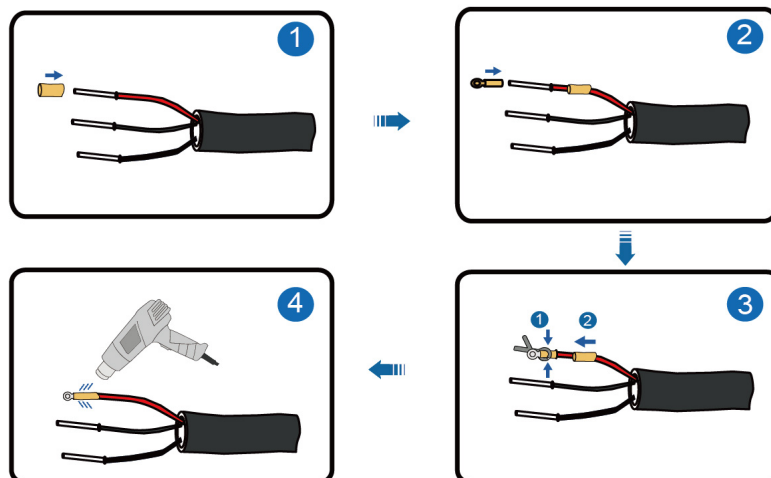

- 4 Connect the cable to the corresponding terminal.

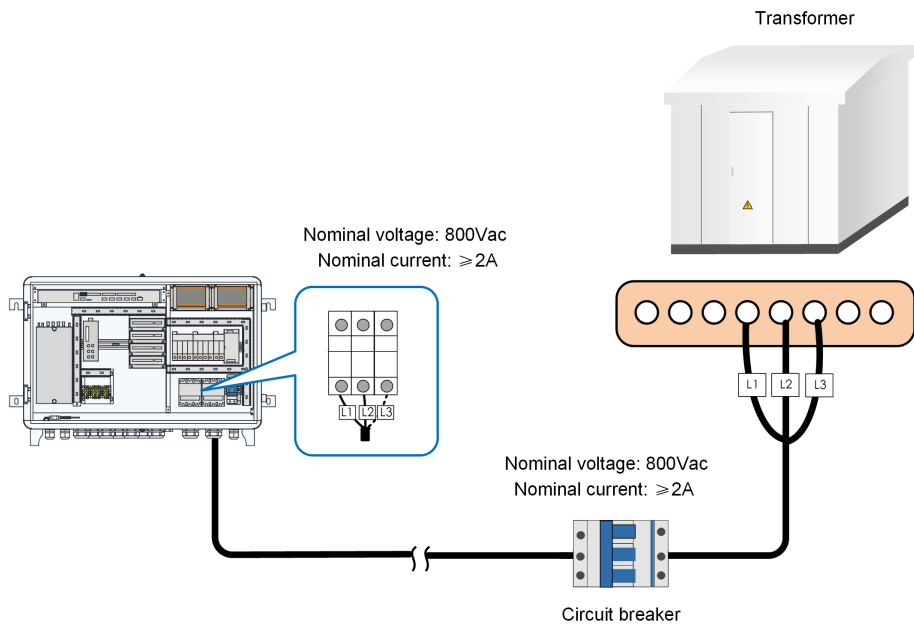

figure 4-11 Three-phase three-wire system



The coupling point for connecting the PLC cable to the box-type transformer busbar is recommended to be arranged in the position corresponding to the middle of the busbar.



- Parameters of the circuit breaker on the box-type transformer side should be determined based on the short circuit current of the transformer.
- Please pay attention to the phase sequence of cables and terminals in the wiring process.

- 5 Fasten the cables with screws after confirming the cables are properly prepared. Tightening torque: 5.5N·m

4.5.6 DI/DO Port Connection

If the purchased model is not equipped with the IO module, the DI/DO port must be directly connected to the logger. For details about how to connect the DI/DO port, scan the following QR code to view the *User Manual* of Logger3000.



If the purchased model is equipped with an IO module, the DI/DO port must be connected to the IO module. For details about how to connect the DI/DO port, scan the following QR code to view the *Quick Installation Guide* of IO Module.



4.6 Post-wiring Processing

NOTICE

Check whether the electrical wiring is completed correctly. If so, seal the cable inlet by filling the clearance around the cable with fireproof mud.

step 1 Gently pull the cable backwards to ensure firm connection when finish wiring.

step 2 Restore the protective cover inside the cabinet.

step 3 Close the cabinet door.

-- End

4.7 Communication Methods

The COM100A can collect the operating data of the inverter, transformer and other equipment in the system and upload it to the remote monitoring system.

Via the remote monitoring system, users can access the WEB interface to view operation information and set parameters.

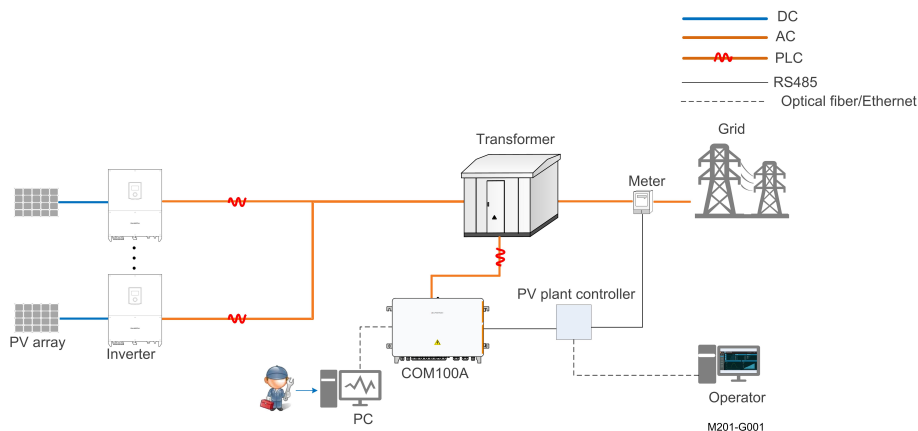

5 Commissioning

5.1 Operation Notices

Before the device is put into operation, read through the “General Safety Instructions” first and ensure the requirements listed therein, as well as requirements mentioned in "Operation Safety", are all met.

⚠ DANGER

When the device is running:

- **Do not touch any live component of the device; otherwise, it may lead to electrical shocks.**
- **Do not touch any wiring terminal on the device; otherwise, it may lead to electrical shocks.**
- **Do not touch any hot part of the device (e.g. heat sink); otherwise, it may cause burns.**

5.2 Inspection before Commissioning

No.	Inspection item
1	All cables are connected correctly and firmly.
2	The phase sequence of all cables is correct.
3	The internal and external grounding points of the device are reliably grounded.

5.3 Commissioning Steps

Commissioning Steps

Item	Description
1	Connect the internal fuse of COM100A.
2	Connect the control switch of AC power supply.
3	Check whether the switch and 24V switch-mode power supply operate normally.
4	Observe running indicators of Logger3000. If the PWR indicator keeps steady on, and the RUN indicator flickers once every second, the device operates normally.
5	Connect the transformer-side circuit breaker.

Configure Logger3000 through WEB Interface

Item	Description
1	Connect PC to the Ethernet port of the switch inside COM100A by using a network cable. IP of the Ethernet port is 13.13.13.13 by default.
2	Set IP of the PC, which should be in the same network segment as that of the ETH2 port of the Logger3000. For example, it can be set to 13.13.13.x (x ranges between 1 and 255, except 13), and the subnet mask can be set to 255.255.255.0.
3	Enter the IP of the Logger3000, such as 13.13.13.13, in the PC address bar, to enter the corresponding Web interface.
4	Configure serial port parameters.
5	Add devices.
6	Configure device IP.
	Configure iSolarCloud address if inverter data needs to be uploaded to iSolarCloud.
7	<ul style="list-style-type: none"> • Accessed iSolarCloud site is "Chinese Server" by default. • In mainland China, set the site to "Chinese Server"; • In Europe, set the site to "European Server". • In other regions, set the site to "International Server".
8	Access the Web interface of Logger3000 and check whether the running data of string inverters manufactured by SUNGROW is normal.
9	Create power plants through iSolarCloud App, and check whether the data displayed on iSolarCloud is normal.

Additional Description

To create power plant through iSolarCloud App, download and install the App and then proceed as follows:

- 1 Log into the Web interface of Logger3000 and click "About", to obtain the QR code.
- 2 Scan the QR code with the App or manually input the S/N to add communication device.

For more details, refer to Logger3000 User Manual, which can be obtained by scanning the foregoing QR code.



6 Troubleshooting and Maintenance

6.1 Maintenance Notices

Before maintenance, read through the “General Safety Instructions” first and ensure the requirements listed therein, as well as requirements mentioned in "Maintenance Safety", are all met.

DANGER

Risk of personal injury or device damage due to improper maintenance!

- Be sure to use specialized insulated tools when performing high-voltage operations.
- Before maintenance, disconnect the upstream power supply and PLC power supply first; otherwise, it may cause personal injury.
- Wait 25 minutes after the device is powered off, then measure the voltage and current with a specialized measurement instrument. Only when no current or voltage is present, operators, who wear protective equipment, can perform operation and maintenance on the device.

WARNING

Power off the device before proceeding with maintenance.

CAUTION

To prevent irrelevant personnel from operating the product by mistake or other accidents, please set up highly visible warning signages or safety warning tapes around the product.

6.2 Troubleshooting

Fault	Possible Cause	Corrective Measures
According to the background monitoring device, some devices in the PV array are abnormally disconnected.	1. RS485 cable is abnormal.	1. Measure the voltage between RS485–A and RS485–B with a multimeter, and check whether the voltage is about 5V.
	2. There are repeated device addresses in the PV array.	2. Check whether there are repeated device addresses.

Fault	Possible Cause	Corrective Measures
	3. Parameters of Logger3000 are incorrectly configured.	3. Check, through the WEB interface " System " -> " Port Paramter " -> " RS485 ", whether the PLC access is enabled.
	4. Master and slave node modules of the PLC are abnormal.	4. Check whether the indicator D12 keeps steady red while the indicator D8 flickers green. If not, the modules are abnormal.
	5. Other causes	If the fault persists, please contact SUNGROW.
According to the background monitoring device, some devices in the PV array are unstably connected.	1. There are repeated device addresses in the PV array.	1. Check whether there are repeated device addresses.
	2. Parameters of Logger3000 are incorrectly configured.	2. Check, through the WEB interface " System " -> " Port Paramter " -> " RS485 ", whether the PLC access is enabled.
	3. Other causes	If the fault persists, please contact SUNGROW.

7 Appendix A: Technical Parameters

Configuration	
Logger	Logger3000
Fibre channel switch (Optional)	2 optical ports, 6 electrical ports
Splice box (Optional)	4-input, 24-output, ST single-mode
Power supply	100–277 Vac, 50/60 Hz
PLC port input voltage	400Vac/480Vac/540Vac/800Vac
PLC power supply voltage	Master node of PLC module: 24 Vdc
Power consumption	<ul style="list-style-type: none"> • Average power consumption: 30W • Max. power consumption: 60W
Ambient parameters	
Operating temperature	- 30°C - +60°C
Storage temperature	- 40°C - +70°C
Operating humidity	5%–95%, non-condensing
Operating altitude	≤4000m
Protection degree	IP65
Mechanical parameters	
Dimensions (W x H x D)	860mm x 610mm x 272mm
Weight	32kg
Installation method	Wall mounting, bracket mounting, and ground mounting
Cable in and out mode	Bottom in, bottom out

8 Appendix B: General Information

8.1 Quality Assurance

When product faults occur during the warranty period, SUNGROW will provide free service or replace the product with a new one.

Evidence

During the warranty period, the customer shall provide the product purchase invoice and date. In addition, the trademark on the product shall be undamaged and legible. Otherwise, SUNGROW has the right to refuse to honor the quality guarantee.

Conditions

- After replacement, unqualified products shall be processed by SUNGROW.
- The customer shall give SUNGROW a reasonable period to repair the faulty device.

Exclusion of Liability

In the following circumstances, SUNGROW has the right to refuse to honor the quality guarantee:

- The free warranty period for the whole machine/components has expired.
- The device is damaged during transport.
- The device is incorrectly installed, refitted, or used.
- The device operates in harsh conditions beyond those described in this manual.
- The fault or damage is caused by installation, repairs, modification, or disassembly performed by a service provider or personnel not from SUNGROW.
- The fault or damage is caused by the use of non-standard or non-SUNGROW components or software.
- The installation and use range are beyond stipulations of relevant international standards.
- The damage is caused by unexpected natural factors.

For faulty products in any of above cases, if the customer requests maintenance, paid maintenance service may be provided based on the judgment of SUNGROW.

8.2 Contact Information

In case of questions about this product, please contact us.

We need the following information to provide you the best assistance:

- Model of the device

- Serial number of the device
- Fault code/name
- Brief description of the problem

For detailed contact information, please visit: <https://en.sungrowpower.com/contactUS>

