

User Manual

High Voltage LFP Battery

SBR064/096/128/160/192/224/256



All Rights Reserved

All Rights Reserved

No part of this document can be reproduced in any form or by any means without the prior written permission of Sungrow Power Supply Co., Ltd (hereinafter "SUNGROW").

Trademarks

SUNGROW and other SUNGROW trademarks used in this manual are owned by SUNGROW.

All other trademarks or registered trademarks mentioned in this manual are owned by their respective owners.

Software Licenses

- It is prohibited to use data contained in firmware or software developed by SUNGROW, in part or in full, for commercial purposes by any means.
- It is prohibited to perform reverse engineering, cracking, or any other operations that compromise the original program design of the software developed by SUNGROW.

About This Manual

The manual mainly describes the product information, guidelines for installation, operation and maintenance. The manual cannot include complete information the system (i.e. the hybrid inverter), just the battery. The reader can get additional information about other devices at www.sungrowpower.com or on the webpage of the respective component manufacturer.

Validity

This manual is valid for the following battery models:

- SBR064
- SBR096
- SBR128
- SBR160
- SBR192
- SBR224
- SBR256

They will be referred to as "battery" hereinafter unless otherwise specified.

Target Group

This manual is intended for battery owners who will have the ability to interact with the battery and qualified personnel who are responsible for the installation and commissioning of the battery. Qualified personnel should have the following skills:

- Training for installation and commissioning of electrical system, as well as dealing with hazards
- Knowledge of the manual and other related documents
- Knowledge of the local regulations and directives

How to Use This Manual

Read the manual and other related documents before performing any work on the battery. Documents must be stored carefully and be available at all times.

Images in this manual are for reference only. The actual product received may differ.

Contents may be periodically updated or revised due to the product development. It is probably that there are changes of manual in the subsequent battery edition. The latest manual can be acquired via visiting the website at support.sungrowpower.com.

Symbols

Important instructions contained in this manual should be followed during installation, operation and maintenance of the battery. They will be highlighted by the following symbols.

DANGER

Indicates a hazard with a high level of risk that, if not avoided, will result in death or serious injury.

WARNING

Indicates a hazard with a medium level of risk that, if not avoided, could result in death or serious injury.

CAUTION

Indicates a hazard with a low level of risk that, if not avoided, could result in minor or moderate injury.

NOTICE

Indicates a situation that, if not avoided, could result in equipment or property damage.



Indicates additional information, emphasized contents or tips that may be helpful, e.g. to help you solve problems or save time.

Abbreviation

BMS: Battery Management System

CAN: Controller Area Network

LFP: Lithium iron phosphate

SOC: State of Charge

PACK: Battery module

Contents

All Rights Reserved.....	I
About This Manual.....	II
1 Safety Instructions.....	1
1.1 Notices for Safe Use.....	2
1.2 Battery Handling Information.....	3
1.3 Emergency Situations.....	4
1.3.1 Leaking Batteries.....	4
1.3.2 Fire.....	5
1.3.3 Wet Batteries.....	6
1.3.4 Damaged Batteries.....	6
2 Product Description.....	7
2.1 Product Introduction.....	7
2.2 Terminal Description.....	9
2.3 Symbols on the Product.....	10
2.4 LED Indicator.....	11
3 Unpacking and Storage.....	13
3.1 Unpacking and Inspection.....	13
3.2 Scope of Delivery.....	14
3.3 Storage.....	15
4 Mounting.....	18
4.1 Safety during Mounting.....	18
4.2 Location Requirements.....	18
4.3 Installation Environment Requirements.....	18
4.4 Installation Clearance Requirements.....	19
4.5 Installation Tools.....	20
4.6 PE Cable Preparation.....	21
4.7 Assemble DC Connectors.....	21
4.8 Assembling the Communication Connector.....	24

4.9 Installing the Battery.....	29
5 Commissioning/Start-up.....	37
5.1 Inspection before Commissioning.....	37
5.2 Commissioning Procedure.....	37
6 Decommissioning the Battery/Shutdown Procedure.....	40
7 Viewing Battery information.....	41
8 Battery Augmentation.....	44
9 Troubleshooting and Maintenance.....	50
9.1 Troubleshooting.....	50
9.2 Maintenance.....	56
10 Appendix.....	58
10.1 Technical Data.....	58
10.2 FAQs.....	60
10.2.1 Battery Not Charging.....	60
10.2.2 Battery Not Discharging.....	61
10.2.3 SOC Jump.....	62
10.2.4 Battery Upgrade.....	62
10.3 Quality Assurance.....	62
10.4 Contact Information.....	63

1 Safety Instructions

When installing, commissioning, operating, and maintaining the product, strictly observe the labels on the product and the safety requirements in the manual. Incorrect operation or work may cause:

- Injury or death to the operator or a third party.
- Damage to the product and other properties.

WARNING

- **Do not perform any operation on the product (including but not limited to, handling, installing, powering on, or maintaining the product, performing electrical connection, and working at heights) in harsh weather conditions, such as thunder and lightning, rain, snow, and Level 6 or stronger winds. SUNGROW shall not be held liable for any damage to the device due to force majeure, such as earthquakes, floods, volcanic eruptions, mudslides, lightning strikes, fires, wars, armed conflicts, typhoons, hurricanes, tornadoes, and other extreme weathers.**
- **In case of fire, evacuate from the building or product area and call the fire alarm. Re-entry into the burning area is strictly prohibited under any circumstances.**

NOTICE

- **Tighten the screws with the specified torque using tools when fastening the product and terminals. Otherwise, the product may be damaged. And the damage caused is not covered by the warranty.**
- **Learn how to use tools correctly before using them to avoid hurting people or damaging the device.**
- **Maintain the device with sufficient knowledge of this manual and use proper tools.**



- The safety instructions in this manual are only supplements and cannot cover all the precautions that should be followed. Perform operations considering actual onsite conditions.
- SUNGROW shall not be held liable for any damage caused by violation of general safety operation requirements, general safety standards, or any safety instruction in this manual.
- When installing, operating, and maintaining the product, comply with local laws and regulations. The safety precautions in this manual are only supplements to local laws and regulations.
- During the product transport, installation, wiring, maintenance, etc., the materials and tools prepared by users must meet the requirements of applicable local laws and regulations, safety standards, and other specifications. SUNGROW shall not be held liable for any damage to the product caused by the adoption of materials and tools that fail to meet the above-mentioned requirements.
- Operations on the product, including but not limited to, handling, installing, wiring, powering on, maintenance, and use of the product, must not be performed by unqualified personnel. SUNGROW shall not be held liable for any damage to the product resulting from operations done by unqualified personnel.
- Where the transport of the product is arranged by users, SUNGROW shall not be held liable for any damage to the product that is caused by users themselves or the third-party transport service providers designated by the users.
- SUNGROW shall not be held liable for any damage to the product caused by the negligence, intent, fault, improper operation, and other behaviors of users or third-party organizations.
- SUNGROW shall not be held liable for any damage to the product arising from reasons unrelated to SUNGROW.

1.1 Notices for Safe Use

Read all safety instructions carefully prior to any work and observe them at all times when working on or with the battery. Failure to observe the precautions described in this section can cause serious injury to persons or damage to property.

⚠ DANGER**Risk of explosion**

- Do not subject the battery to any strong force.
- Do not mechanically damage the battery (pierce, deform, strip down, etc.)
- Do not heat the battery or dispose of the battery in a fire.
- Do not install the battery in potentially explosive environments.
- Do not place the battery in water or other liquids.

⚠ DANGER**Risk of fire**

- Do not place the battery near a heat source, such as direct sunlight, a fireplace, a thermally uninsulated wall exposed to sunlight, hot water, or a heater.
- Keep sources of ignition such as sparks, flames, and smoking materials away from the battery.

⚠ DANGER**Risk of electric shock**

- Do not disassemble the battery.
- Do not handle a wet battery or use wet tools.
- Do not soak the battery in water or expose it to moisture or liquids.
- Keep the battery away from children and animals.
- Wear suitable clothing, guards and gloves to prevent you from direct contact with the DC voltage.
- Use insulated tools during working with battery.
- Set aside metal jewelry before working on the DC circuit.

1.2 Battery Handling Information

NOTICE

Follow local standards to use the battery.

Any man-made damage will void the limited warranty for the battery. Handle the battery with care to protect it from damage.

- Use the battery only as intended and designed.
- The battery must only be installed at a suitable location.
- Make sure the battery is well connected to ground before use.
- Do not use the battery if it is defective, appears cracked, broken or damaged, or fails to operate.
- Do not use the battery together with other types of batteries.
- Do not pull, drag or step on the battery.
- Do not leave any foreign objects inside the battery.
- Do not repair or modify the battery. It is not user serviceable.
- Do not pull out any cables when the battery is powered on.
- Do not damage the sheath of cables, wire harness and connectors.
- While the battery is charged, used and stored, keep it away from materials that are prone to electric discharge, including static discharge.
- Keep the battery away from babies and children to avoid any accidents.
- Cover terminals with insulating tape before proper disposal.
- Avoid direct contact with rain, snow, and water, and prevent the battery from falling and mechanical impact during battery transportation.

1.3 Emergency Situations

1.3.1 Leaking Batteries

Abuse/misuse/damage of the battery may cause increasing of internal pressure in the battery cells. It may result in the electrolyte venting. In the event that battery electrolyte is released:

- Do not enter the room under any circumstance.
- Avoid contact with the leaking liquid or gas.
- Call the Local Emergency number or Fire Brigade if necessary.

If one is exposed to the leaking substance, follow the suggestions below to minimize the chance of injury:

- Inhalation: Evacuate the contaminated area, and seek medical aid.
- Eye contact: Rinse eyes with copious amounts of water for at least 15 minutes, and seek medical aid immediately.

- Skin contact: Wash the affected area thoroughly with plenty of water for at least 15 minutes. If possible, remove or saturate contaminated clothing with water. Seek medical aid if the patient is distressed.
- Ingestion: Induce vomiting, and seek medical aid immediately.

Wipe out the contacted area with a sponge or cloth that is soaked in water until you obtain medical aid. These materials can damage skin and eyes, causing blindness.

1.3.2 Fire

Fire may occur with the battery despite its careful design. Likewise, a fire or unusually high temperatures near the battery can cause it to catch fire.

Protective equipment

A respirator is not required during normal operations.

In the event of a fire, hazardous fumes including carbon monoxide, carbon dioxide, and/or various hydrocarbons may be emitted. To comply with the Personal Protective Equipment Directive (89/686/EEC), use a full-face self-contained breathing apparatus (SCBA) with full protective gear during fire fighting.

Fire fighting

NOTICE

In the event of a fire, only qualified firefighters with appropriate protective equipment are permitted to enter the room where the battery is located.

It may take a long time to completely extinguish the fire. Consider allowing the system to burn. Smoke indicates that the battery is still burning. Always note that there is a risk of the battery re-igniting.

Proceed as follows for fire-fighting.

1. Shut off any connected power system or electronics such as the battery, battery isolator, PV DC isolator(s), AC isolator, solar supply main switch and normal supply main switch.
2. Perform an adequate knock down on the fire before entering the incident's hot zone.
3. If the battery catches on fire, use fire-fighting sand, CO₂ extinguisher, or other emergency fire extinguishing equipment approved by fire fighters to extinguish the fire.
4. If the fire is not from the battery and has not spread to it yet, use an ABC fire extinguisher to extinguish the fire. Remove batteries and other ignition sources from the scene of a fire.

1.3.3 Wet Batteries

If the battery is submerged in water, do not let people access it, and then contact Sungrow or an authorized service partner for technical support.

If a battery is submerged in water or flooded, first, switch off all circuit breakers in the system to cut off the power supply to the battery. Wait until floodwaters subside and do not approach near battery. If someone needs to go into the flooded water, wear insulated full length rubber boots and gloves.

Do not use a flooded battery again.

1.3.4 Damaged Batteries

The battery consists of lithium-ion cells. These are considered dry cell batteries. If the battery is damaged, only a small amount of battery fluid can leak.

A damaged battery can cause rapid heating of the battery cells. If you notice smoke coming from the battery area, assume that the battery is burning and take appropriate action as described in [1.3.2 Fire](#).

Damaged batteries are dangerous and must be handled with extreme caution. They are not fit for use and may pose a danger to people or property. If a battery seems to be damaged:

1. Pack it in its original container.
2. Store it in a separated room like the installation place.
3. Contact SUNGROW.

DANGER

A damaged battery may release dangerous material and a flammable gas mixture. Never try to repair the battery even if you are a qualified electrician.

2 Product Description

2.1 Product Introduction

Brief Introduction

The battery is designed for residential energy storage systems. The inbuilt battery management system monitors its operation and prevents the battery from operating beyond the specified limitations.

This product is a high-voltage battery system with an operating voltage range between 108 V ~ 584 V. A battery system consist of 2 to 8 individual battery modules connected in series.

Max.4 battery systems can be connected in parallel to compatible hybrid inverter. Please refer to hybrid inverter manual for the compatibility details.

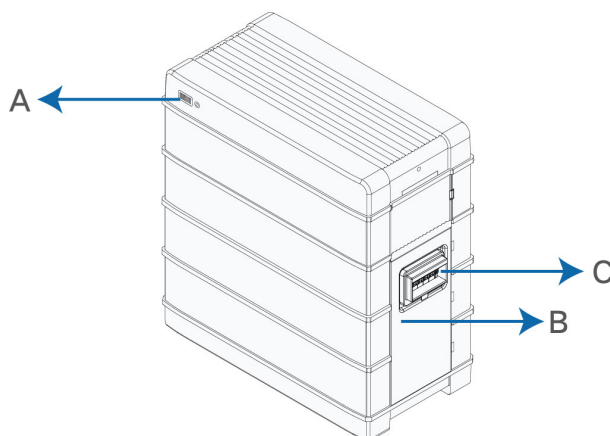

figure 2-1 Product overview

NOTICE

SBR064 is only applicable to SH3.0-6.0RS and SH5.0-10RT/-20.



Images are for reference only. The actual products received may differ.

table 2-1 Design of the product

Position	Designation
A	LED Indicator LED indicator include the SOC indicator and the status indicator. The status indicator is also used as the power button. LED indicator indicates the SOC value and status of the battery system.
	Nameplate The nameplate clearly identifies the product. The nameplate must remain permanently attached to the product. You will find the following information on the nameplate: <ul style="list-style-type: none"> • SUNGROW logo and product model • Technical data • Product symbol
C	DC circuit breaker

Major Components

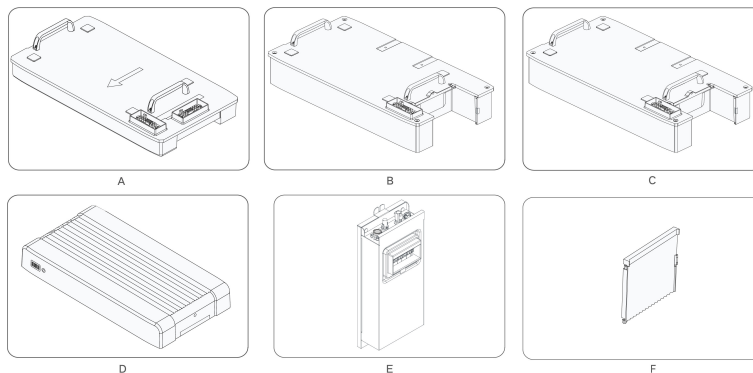

Images are for reference only. The actual products received may differ.

Name	Designation
A	Base
B	Battery module
C	Empty module
D	Top cover
E	Switch gear
F	Empty module*

NOTICE

Battery module: Single module is 3.2 kWh and used in SBR064-256 battery system.

***Empty module:** 1. Decorative accessory, which makes the battery height higher, and on the SBR064, which makes the switch gear fit perfectly into the modules.

2. It has the same appearance as Battery module, with a built-in conduction line and does not contain battery cells.

3. Standard on SBR064, optional on SBR096-256.

table 2-2 Configuration Table

No.	Model	Base	Battery module	Top cover	Switch gear	Side cover
1	SBR064	1	2	1	1	2
2	SBR096	1	3	1	1	3
3	SBR128	1	4	1	1	4
4	SBR160	1	5	1	1	5
5	SBR192	1	6	1	1	6
6	SBR224	1	7	1	1	7
7	SBR256	1	8	1	1	8

2.2 Terminal Description

All electrical terminals are located at the switch gear.

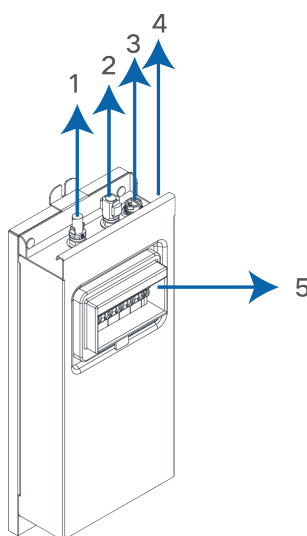













Images are for reference only. The actual products received may differ.

No.	Label	Description
1	P-	The system negative terminal, connected to the hybrid inverter negative terminal
2	P+	The system positive terminal, connected to the hybrid inverter positive terminal
3	COMM	To enable the communication between the hybrid inverter and the battery
4		Grounding terminal, connected to the ground
5	DC circuit breaker	To connect/disconnect the DC circuit, for power-on, power-off, and short-circuit protection

2.3 Symbols on the Product

Symbol	Explanation
	Pay attention to the danger. Do not operate this product in the live status!
	No open flames Do not expose to flame, incinerate, puncture, or impact.
	Electric shock hazard Serviced by qualified personnel only. Out of reach from children.
	TÜV mark of conformity
	TÜV mark of conformity
	CE mark of conformity EU/EEA Importer
	UKCA mark of conformity
	Do not dispose in trash. Compacting a lithium ion battery is dangerous as it can explode.
	Please recycle this lithium ion battery. Do not discard.

Symbol	Explanation
	Read the user manual before maintenance!
	This is a protective grounding terminal, which should be grounded securely to protect the safety of operators.

2.4 LED Indicator

LED indicators include the SOC indicator and the status indicator. The status indicator is also used as the power button.

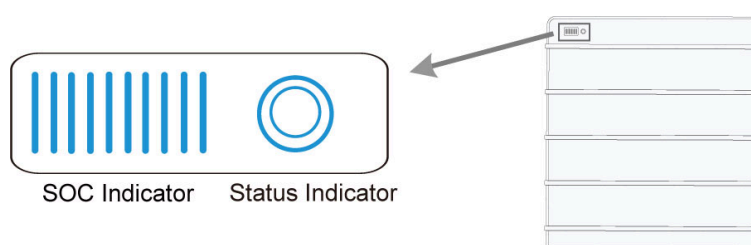



SOC Indicator

The SOC indicator indicates the current SOC value of the battery. One bar indicates the SOC value of 10%.



Status Indicator

The Status indicator indicates the current state of the battery.

LED color	LED indicator	LED state	Definition
	Blue	ON	Normal operation (without fault)
		Slow blink Period: 2 s	The battery is at power-on or standby state or firmware update state(without fault).
		Fast blink Period: 0.5 s	Battery self-test in process.
	Red	ON	A system fault has occurred.
		Blink	The battery is at power-on or standby state (with primary fault).



Images are for reference only. The actual products received may differ.

The status indicator can be used to power on the battery.

Operation	Definition
Press and hold for less than 2 seconds	To power on the battery*

NOTICE

*The start mode is black start, please refer to [5.2 Commissioning Procedure](#) for details.

3 Unpacking and Storage

3.1 Unpacking and Inspection

The product is thoroughly tested and strictly inspected before delivery. Nonetheless, damage may still occur during shipping. For this reason, please conduct a thorough inspection after receiving the product.

- Check the packing case for any visible damage.
- Check the scope of delivery for completeness according to the packing list.
- Check the inner contents for damage after unpacking.

Contact SUNGROW or the transport company in case of any damage or incompleteness, and provide photos to facilitate services.

Do not dispose of the original packing case. It is recommended to store the device in the original packing case when the product is decommissioned.

NOTICE

- **After receiving the product, check whether the appearance and structural parts of the device are damaged, and check whether the packing list is consistent with the actual ordered product. If there are problems with the above inspection items, do not install the device and contact your distributor first. If the problem persists, contact SUNGROW in time.**
- **If any tool is used for unpacking, be careful not to damage the product.**

3.2 Scope of Delivery

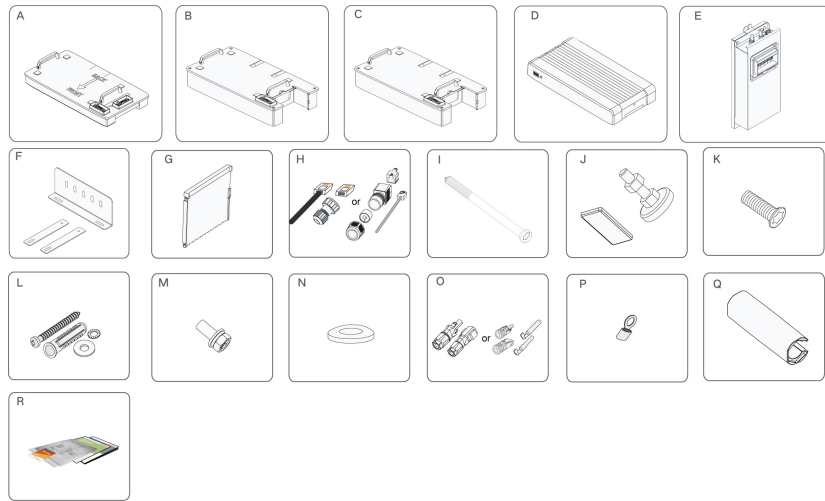

Item	Name	Quantity
A	Base	1
B	Battery module	2 - 8
C	Empty module*	1
D	Top cover	1
E	Switch gear ¹	1
F	Bracket	1
G	Side cover	2 - 8
H	Communication connector	1
I	M5*125 hex socket screw (optional)	1
J	Foot	4
K	M5*14 hex socket screw ²	14 - 24
L	Expansion plug set	2
M	M5 screw sets ²	6
N	M6 fender washer ²	5
O	SUNCLIX connector or MC4 Connector	1
P	OT terminal	1
Q	Communication cable fastening tool**	1
R	Documents	1



1. Images in this manual are for reference only. The actual product received may differ.
 2. The number of parts marked with “2” is greater than required. Please refer to the installation steps for the specific quantity needed.
- * Only SBR064 provides empty module, SBR096-256 does not provides empty module.
- ** This accessory is intended for circular communication connectors only.

3.3 Storage

Proper storage is required if the battery is not installed immediately.

- Store the battery in the original packing case with the desiccant inside.
- Preferably, keep the temperature in the range of 15°C - 25°C and install the battery as soon as possible. Store the battery within the temperature range of -10°C to 35°C. The storage time has to be ≤6 months, and the storage should not exceed 12 months.

(The start of the storage time is the production time of the battery module. The production time can be checked by Sungrow sales network such as local distributors via the Serial Numbers of the battery modules.) The procedure is the following: Each battery module comes with a serial number label. This label is typically found on the side or top of the battery module or on the packaging of the battery module. The production date is encoded within the serial number and can be determined as follows:

EM	134	D	2	21	8	20	0289	D	A
				Year	Month	Day			

- In ideal conditions the maximum storage time for the battery is 12 months. However due to uncertainties regarding the warehouse conditions for example temperature fluctuations outside the normal storage range, it is required to recharge the battery to 30% SOC every 6 months of storage.
- Handle the batteries with care. Pay attention to the harsh environment, such as sudden cooling/heating and collision, to avoid damage to the battery.
- The storage relative humidity must be always between 0 and 95%, non-condensing.
- Store the battery in a clean and dry place, without exposure to sunlight and rain. The storage location must be free of harmful gases, flammable/explosive products and corrosive chemicals. The battery should be prevented from mechanical impact, high pressure, high-intensity magnetic field and direct exposure to sunlight.
- The number of stacking layers of battery modules with package must not exceed 6. It is strictly forbidden to directly stack batteries without package.

- Regularly inspect the package for damage and insect bites. If any damage is found, the product should be replaced immediately.
- The packing and batteries should be upright.
- Always use the oldest stored batteries first to ensure none are stored beyond their recommended period.
- Lithium batteries are recommended to be recharged within 12 months of storage at recommended temperature or transportation.



If the battery is stored over one year, min.5% and max.10% SOH of the capacity may lose irreversibly according to the level of the improper storage.



In case a battery needs to be charged, because it has been stored for more than 12 months, please gather necessary equipment such as an hybrid inverter, connecting cables and safety gear and follow chapters 4 to 5 of this user manual for a proper installation.

1. In the Energy Management Parameters, continue to set the compulsory charging mode in our iSolarCloud (Web-based version or App) of the hybrid inverter.

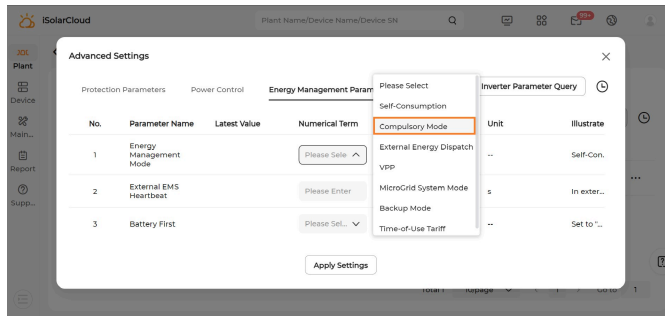

2. Set the lower SOC limit to 30%.

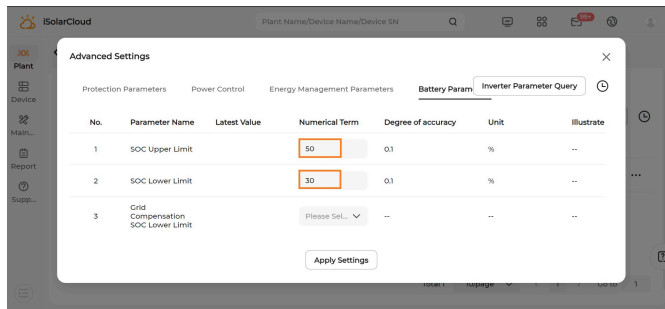

3. Select Charge as the charging command and an appropriate charging power. Monitor the charging process to ensure the SOC reaches 30%. Once charging is complete, disconnect the battery from the hybrid inverter safely.

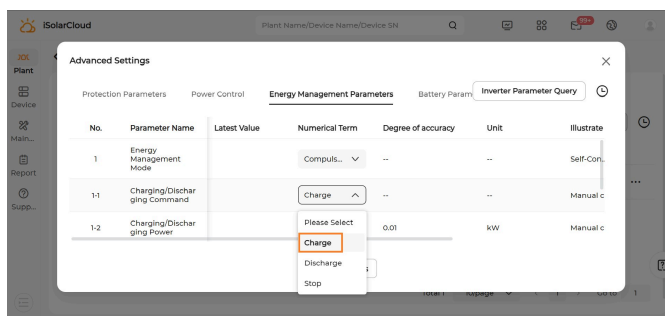

4 Mounting

4.1 Safety during Mounting

WARNING

This product or system must be operated by professionals!

Failure to follow the safety instructions in this manual or operation of this product or system by non-professionals may cause severe personal injury or major property damage.

WARNING

Strictly follow local relevant standards and requirements in the whole process of installation.

4.2 Location Requirements

Select an optimal mounting location for safe operation, long service life and expected performance.

The battery with IP55 can be installed both indoors and outdoors.

Install the battery in a place convenient for electrical connection, operation, and maintenance.

4.3 Installation Environment Requirements

- The installation environment must be free of inflammable or explosive materials.
- The location should be not accessible to children.
- In order to ensure that the battery has a better working condition and longer service life, it is recommended to install the battery at a temperature of 10-30°C throughout the year environment. Please refer to [10.1 Technical Data](#) for the maximum operation temperature range.
- The relative humidity must be always between 0 and 95%, non-condensing.

- Avoid direct exposure to sun, rain and snow.
- The battery should be well ventilated. Ensure air circulation.

4.4 Installation Clearance Requirements

- Reserve enough clearance around the battery to ensure sufficient space for heat dissipation.

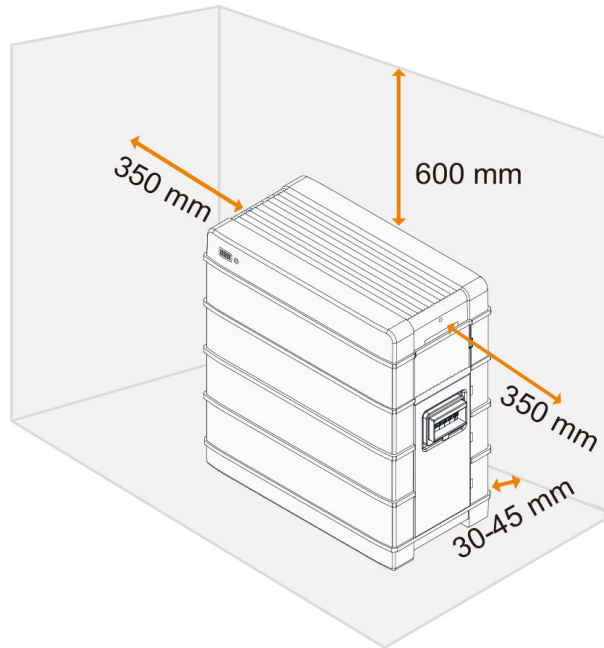

- In case of multiple batteries, reserve specific clearance between the batteries.

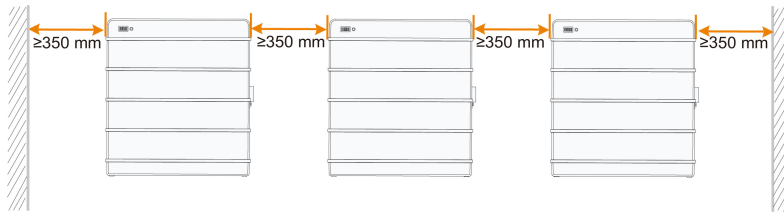











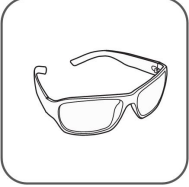
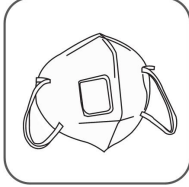



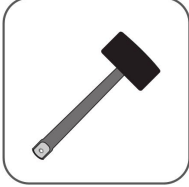

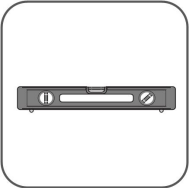
NOTICE

The distance is only the recommended distance, which can be adjusted according to the actual situation.

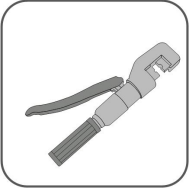
4.5 Installation Tools

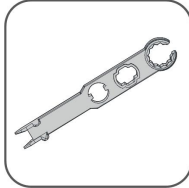
Installation tools include but are not limited to the following recommended ones. If necessary, use other auxiliary tools on site.

table 4-1 Tool specification

			
Goggles	Dust mask	Protective gloves	Insulated shoes
			
Utility knife	Marker	Rubber mallet	Measuring tape
			
Level	Hammer drill (φ10)	Torque screwdriver (ST6.3,M4,M5,M6)	Torque wrench (16mm, 17mm, 35mm)
			
Hydraulic plier	Heat gun	Allen wrench (M5)	MC4 Wrench
			

Tube terminal crimping tool	Wire stripper	MC4 terminal crimping tool(4–6 mm ²)	Electric screwdriver(ST6.3,M4,M5,M6)
-----------------------------	---------------	--	---------------------------------------

4.6 PE Cable Preparation

Additional grounding cable is prepared by customers.

table 4-2 Cable requirements

Type	Specification
Complying with 1000V and 105°C standard	4–6 mm ²

Prepare the cable and OT/DT terminal.

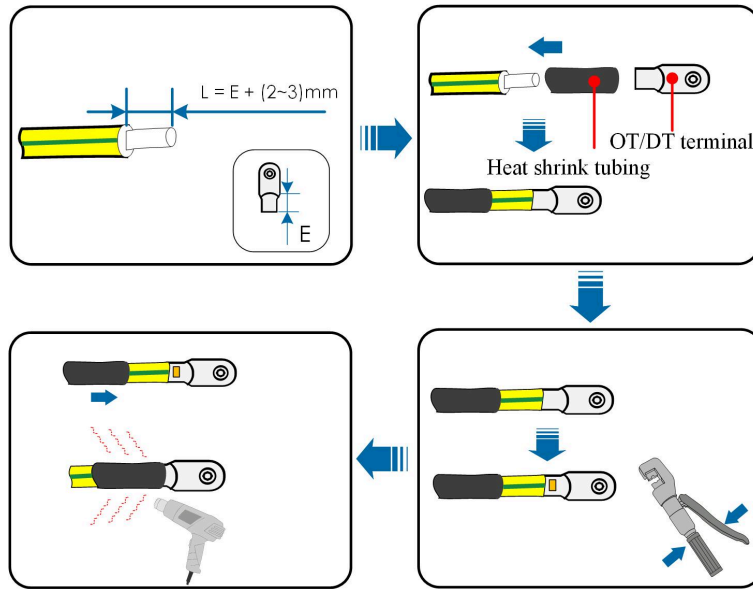

4.7 Assemble DC Connectors

Assembling the MC4 Connectors



To ensure IP65-rated protection for the DC connectors, use only the provided connectors.

1. Strip the insulation from the cable by 7 mm - 8 mm.

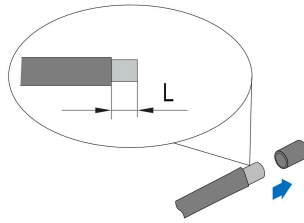

2. Assemble the cable ends with the crimping pliers.

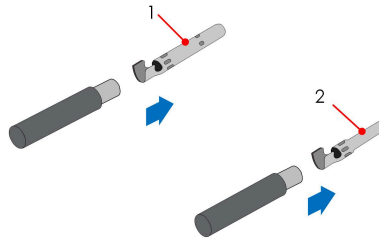

1: Positive crimp contact

2: Negative crimp contact

3. Lead the cable through cable gland, and insert the crimp contact into the insulator until it snaps into place. Gently pull the cable backward to ensure firm connection. Tighten the cable gland and the insulator (torque 2.5 N•m to 3 N•m).

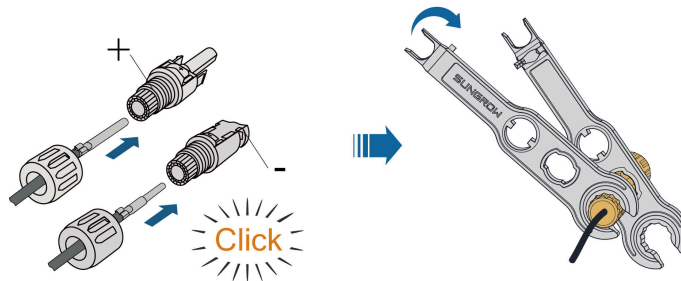

NOTICE

Tighten the MC4 connector at a torque of 2.5 N•m to 3 N•m. Failure to do so may lead to a risk of waterproofing failure.

Assembling the SUNCLIX Connector

NOTICE

During assembly, be careful not to contaminate, pull out, or shift, the seal in the cable gland. A contaminated or shifted seal impairs strain relief and leak tightness.

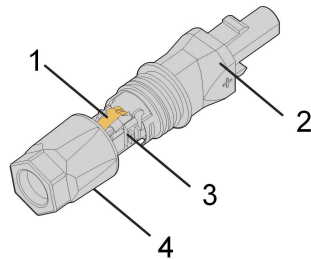
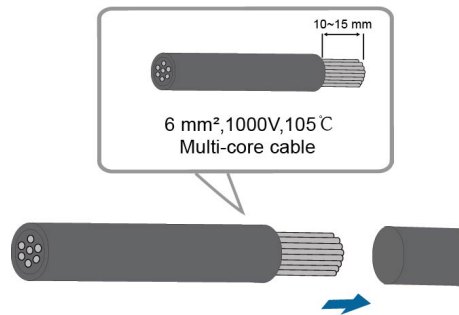

figure 4-1 SUNCLIX Connector Components

1: Spring 2: Sleeve 3: Insert 4: Cable gland

1. Strip the insulation from the cable by 10mm - 15 mm.



2. Pry the connection open and pull the sleeve and the insert apart.

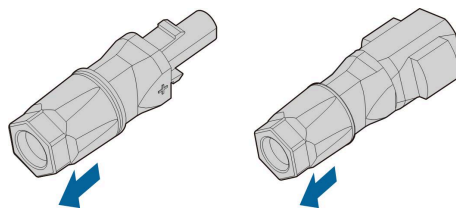

3. Insert the stripped cable into the cable gland up to the stop. The stranded wire can be seen inside the spring. Press the spring down until it audibly snaps into place.

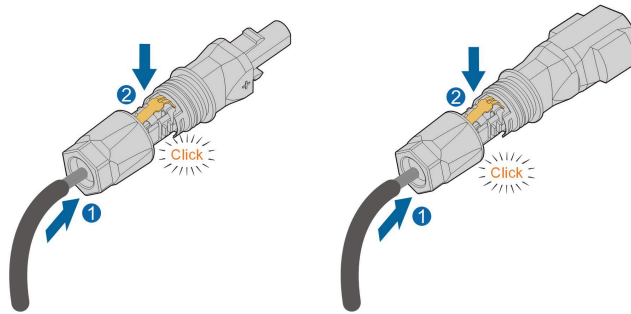

4. Push the insert into the sleeve and tighten the cable gland (torque 2 N·m).

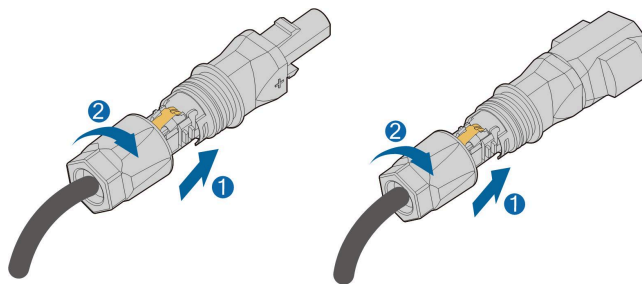

4.8 Assembling the Communication Connector



If the communication connector received is G2, please skip this step.

Two types of communication connectors are available for the battery products. The communication connector that comes with the delivery should prevail.

Circular Communication Connector

1. Unscrew the swivel nut from the connector.

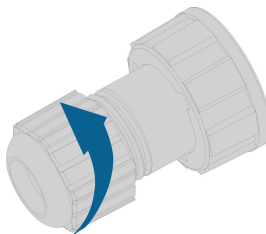

2. Remove the inner rubber gasket.

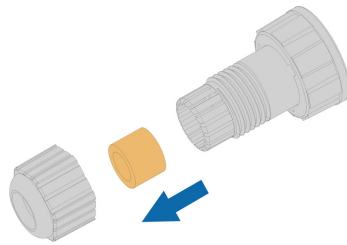

3. Insert the RJ45 plug into the front plug connector until there is an audible click, and install the rubber gasket.

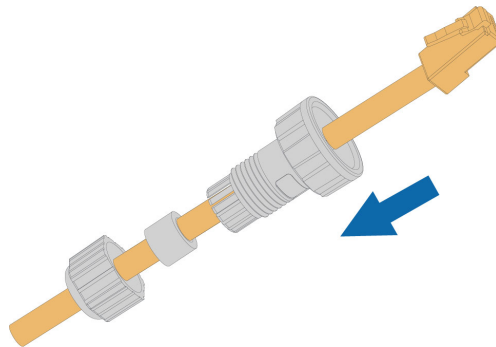

It is recommended that the RJ45 connector be exposed 9–11 mm outside the communication connector.

4. Tighten the swivel nut.

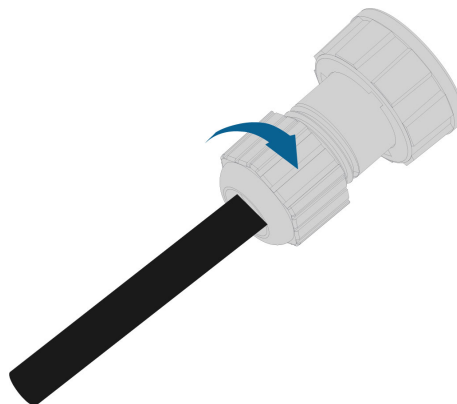

Square-shaped Communication Connector

1. Prepare the required materials.

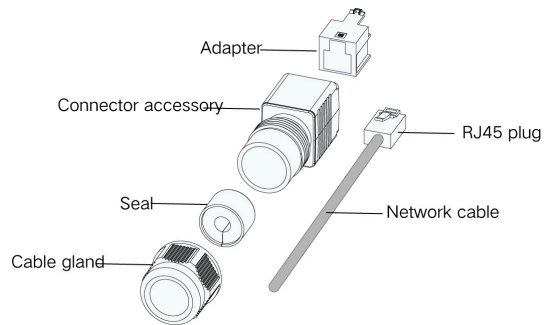

2. Crimp the RJ45 plug on the cable, and lead it through the cable gland and then the connector accessory.

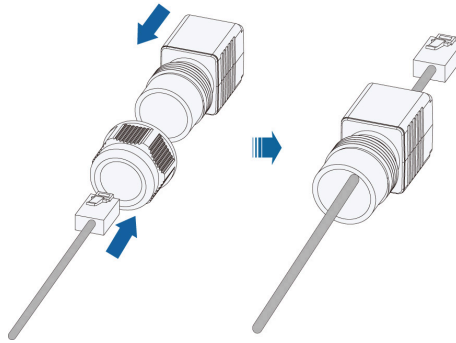

3. Put the adapter on the RJ45 plug. Then, fit the assembly of adapter and RJ45 plug, along with the network cable, into the connector accessory.

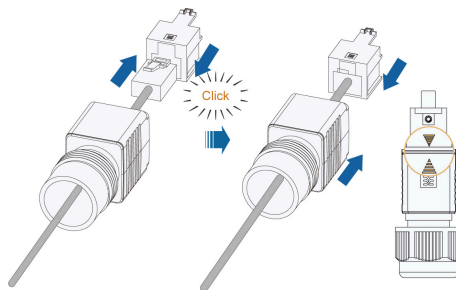

4. Put the seal into place.

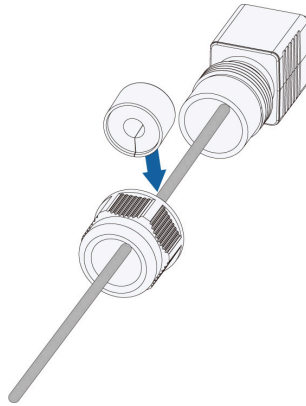

5. Fit the seal and the cable gland.

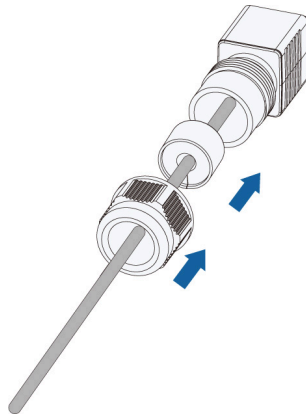

6. Tighten the cable gland (at a torque of 1.8–2.0 N.m).

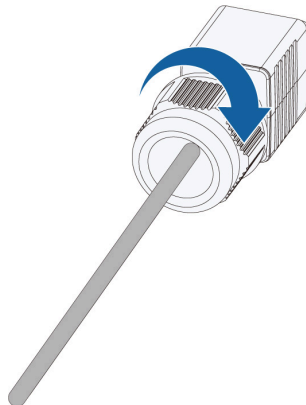

Removing the Square-shaped Communication Connector

1. Loosen the cable gland on the communication connector.

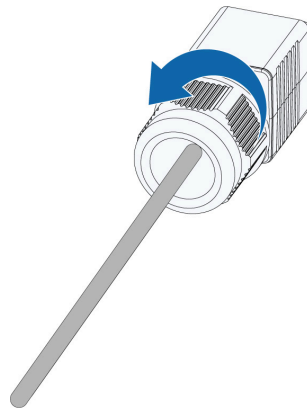

2. Press down on the tab to push the adapter out.

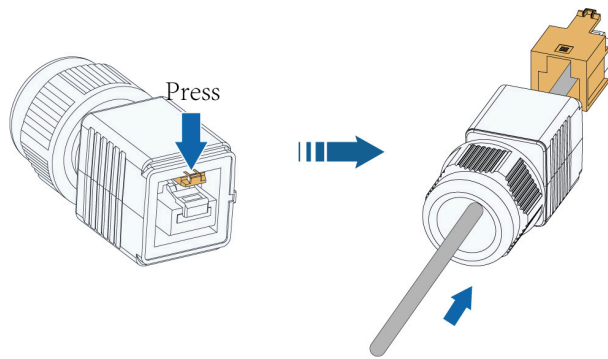

3. Press down on the adapter to pull out the network cable.

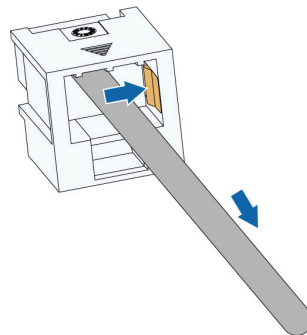

4.9 Installing the Battery



Assemble the battery on a flat surface.

The SBR128 mounting will be used as an example.

step 1 Install the feet of the battery.

Method 1

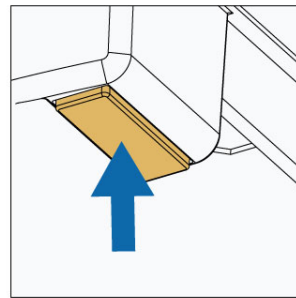
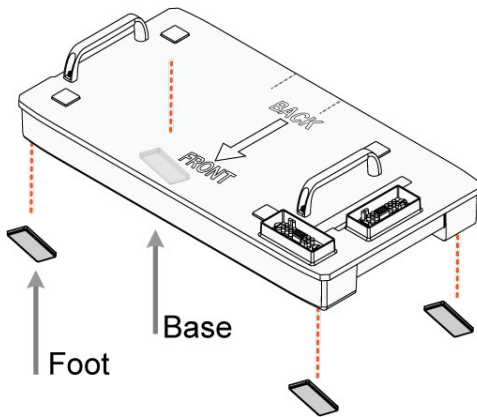

Method 2

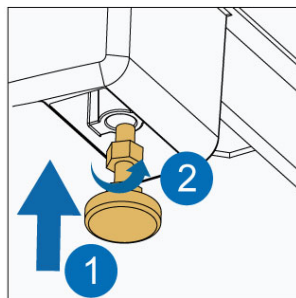
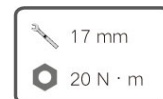
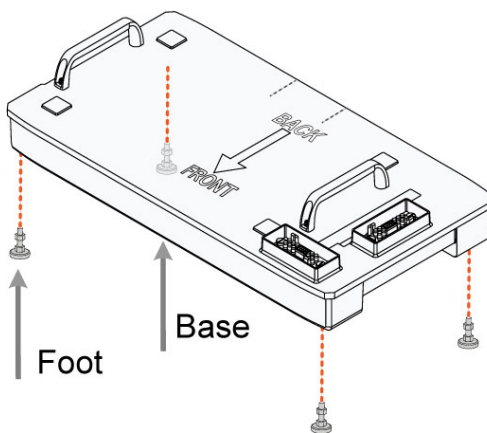

step 2 Align the base with the wall, and keep a distance of 30 mm to 45 mm between the base and the wall. Mark the hole positions of the mounting bracket with a marker according to the required layout of holes.

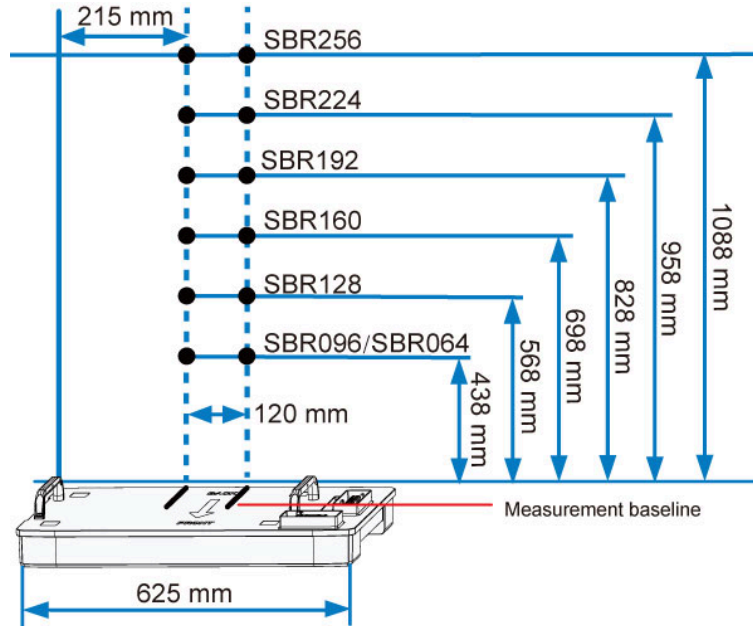

Mark the hole positions along a line vertical to the measurement baseline.

The feet of the base have been installed already.

step 3 Drill the holes according to the marked positions, and install the expansion sleeves.

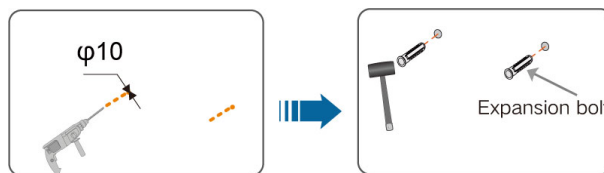

NOTICE

Goggles and gloves are necessary when drilling holes for protection. Shield the battery during drilling. After drilling, clean up debris in time.

step 4 Position the base maintaining the required distance from the wall.

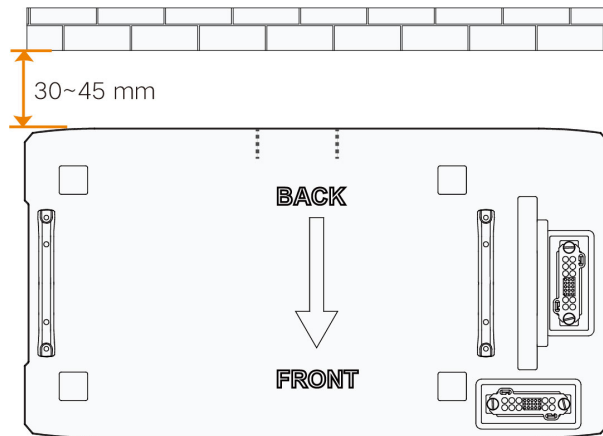

step 5 Place each battery module on top of the base.

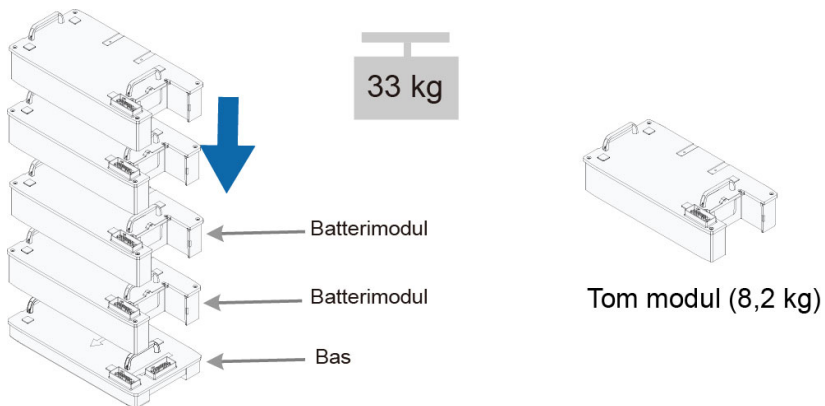

- When carrying the battery module, always be aware of its weight of 33 kg.
- The empty module can be placed anywhere during installation.

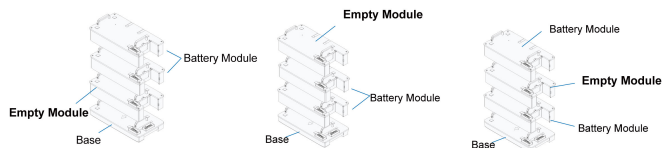

step 6 Fix the battery to the wall.

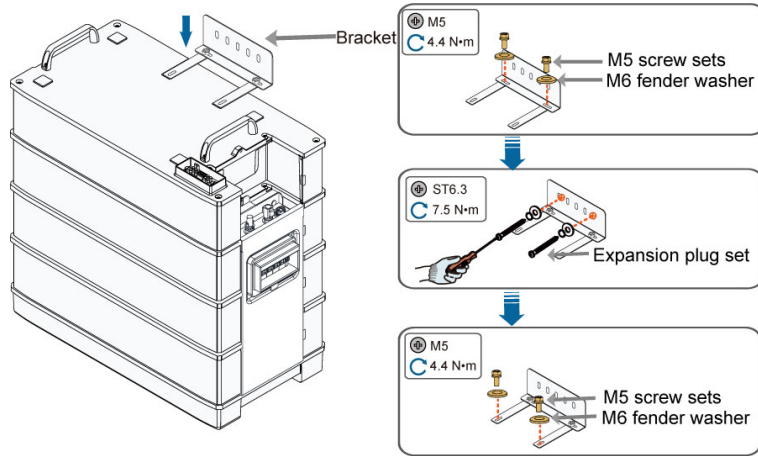

The bracket is mounted on the top battery module.

The mounting position can be fine-tuned through oval holes in the back.

Goggles and gloves are necessary when drilling holes for protection. Shield the battery during drilling. After drilling, clean up debris in time.

step 7 Fix the battery modules with the included screws.

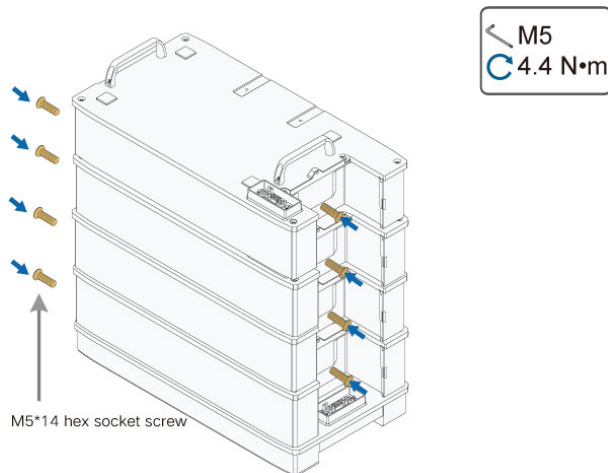

step 8 Connect the switch gear to the base.

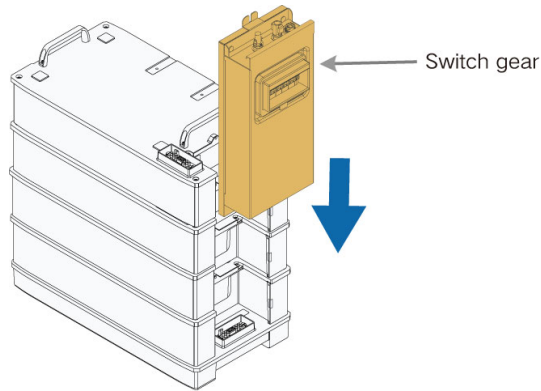

Ensure that the DC circuit breaker is disconnected.

step 9 Fix the switch gear with the provided M5 screw or stud.

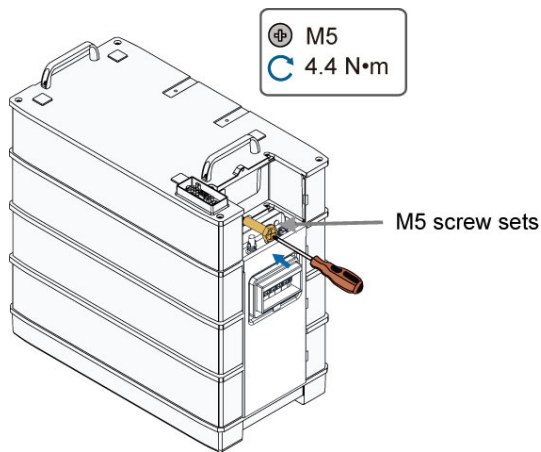

When 4 or more than 4 battery modules are installed in one base, M5 screw set is required to secure the switch gear. The stud is mounted on the top of battery module.

step 10 Connect the harness.

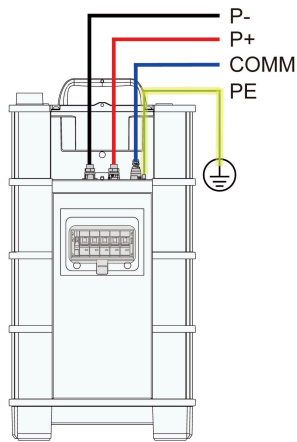

Connection Diagram

Circular Communication Connector :

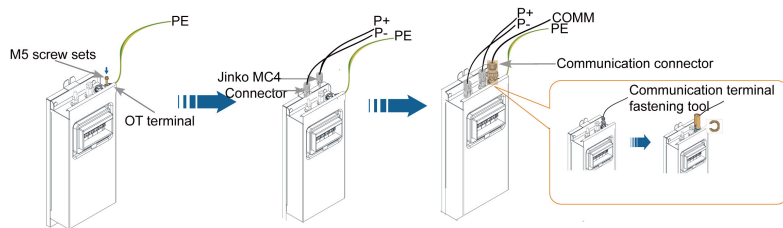

Square-shaped Communication Connector:

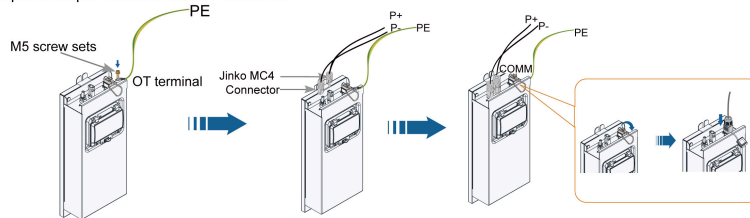

For communication between the battery and the hybrid inverter, after connecting the communication cable to the COMM port, use the communication cable fastening tool to tighten the cable clockwise. Then connect to the hybrid inverter using the other end of the communication cable. Strip the insulation layer of the communication cable with a wire stripper, and lead the corresponding CAN1_H/CAN1_L signal cable out. Cut off the redundant signal cable and wrap it with a heat-shrink tubing. Signal cable 1 white and orange cable is used as CAN1_H; and signal cable 2 orange cable is used as CAN1_L.

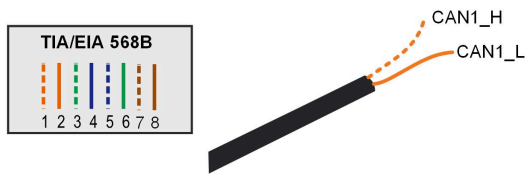

NOTICE
Please ensure that the MC4 cable are connected to same terminals, as shown below.

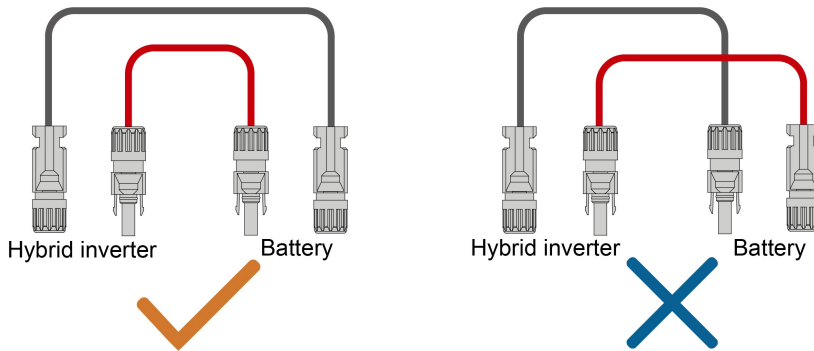

step 11 Place the top cover and fix it with the screws provided.

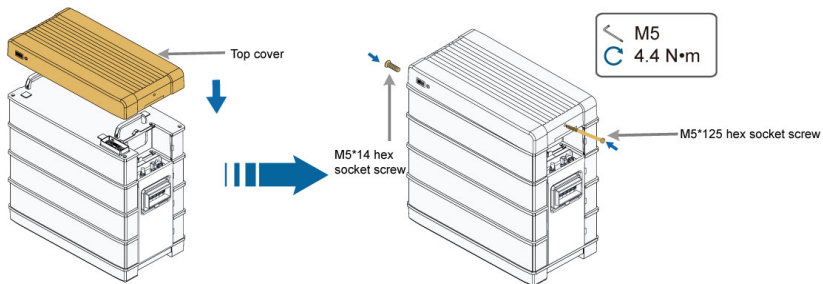

i Secure the power cables and the communication cable near the battery respectively using cable ties (do not bind the power cable and communication cable together) and ensure a U-curve in the cables, as shown in the figure below. This restricts the cable movement and reduces the risk of water flowing into the battery along the cables.

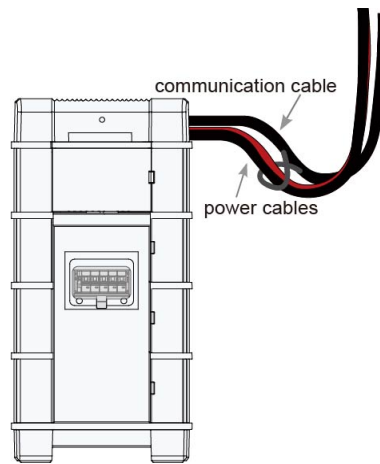

step 12 (Optional) Install the side covers.

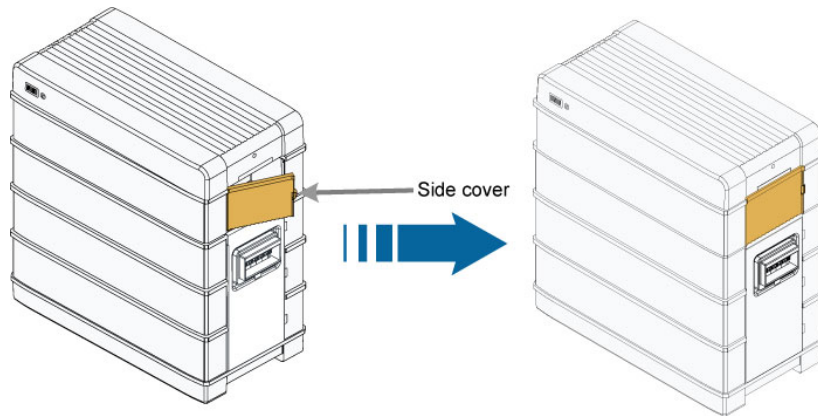

When 4 or more than 4 battery modules are installed in one base, side covers are required.

-- End

5 Commissioning/Start-up

5.1 Inspection before Commissioning

Check the following items before starting the battery:

- Check that the battery system has been installed completely.
- Check that the appearance of the battery system is intact.
- Check that the battery system output wiring harness is correctly connected to the positive and negative terminals of the battery and hybrid inverter to avoid misconnection and reverse connection.
- If a combiner box is used, check whether the connection between the battery and the combiner box and the connection between the combiner box and the hybrid inverter is complete, and whether the positive and negative terminals are correctly connected. (Combiner box not sale in EU)

5.2 Commissioning Procedure

If all of the items mentioned above meet the requirements, proceed as follows to start up the battery for the first time.

step 1 Connect all the switches on the AC and DC sides of the hybrid inverter.

step 2 Manually connect the DC breaker on the right side of the battery so that the BMS enters the self-test state. The status indicator blinks in blue. Wait until the indicator is steady on in blue, which indicates that the battery system is powered on and runs normally.

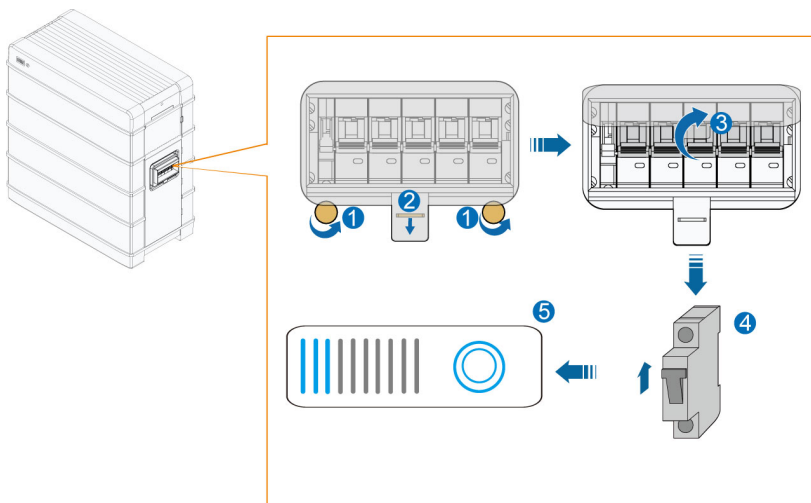



Black Start:

If the communication is established for the first time between the battery and the hybrid inverter, and the hybrid inverter has no DC power supply and no AC power supply. Manually connect the DC breaker on the right side of the battery so that the BMS enters the self-test state. The status indicator blinks in blue. Ten seconds later, press and hold the status indicator for less than 2 seconds. Wait until the indicator is steady on in blue, which indicates that the battery system is powered on and runs normally.

step 3 Close the protective cover.

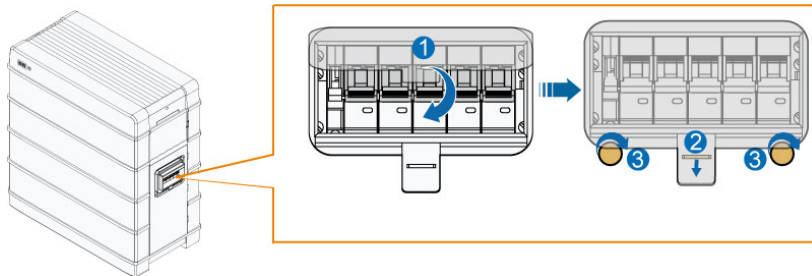

⚠ WARNING

During commissioning, if there is a short-circuit fault in the battery system, disconnect the power cable between the switch gear and the hybrid inverter, check the battery system wiring, and eliminate the short-circuit fault point. Execute step 2, check whether there is a fault in the battery (the indicator light is red), and obtain fault information through iSolarCloud to contact SUNGROW to repair the battery system.

NOTICE

The battery can only be connected to hybrid inverter produced by **SUNGROW**, as listed below:

- **Three-phase model: SH5.0RT, SH6.0RT, SH8.0RT, SH10RT, SH15T, SH20T, SH25T.**
- **Single-phase model: SH3.0RS, SH3.6RS, SH4.0RS, SH5.0RS, SH6.0RS.**



Pay attention the hybrid inverter firmware version should be same that is illustrated in hybrid inverter manuals.

-- End

6 Decommissioning the Battery/Shutdown Procedure

Decommission the battery in the system after the hybrid inverter is decommissioned.
Proceed as follows to decommission the battery.

step 1 Disconnect the DC circuit breaker.

step 2 One minute after the DC circuit breaker is disconnected, disconnect all cables between the battery and other devices.

-- End



Contact SUNGROW to dispose of the battery.

WARNING

If a combiner box is used, power off the DC and AC sides of the hybrid inverter, and disconnect DC circuit breaker of all battery systems before operating the battery system.

7 Viewing Battery information

NOTICE

If you want to check battery information, please complete the plant creation in iSolarCloud first. For details on how to create a plant in iSolarCloud, please refer to *iSolarCloud App User Manual*, which can be obtained by scanning the following QR code.



Viewing Battery information on iSolarcloud App

1. Log in to the iSolarCloud App, tap **Overview**, the battery charging energy from PV then be displayed.

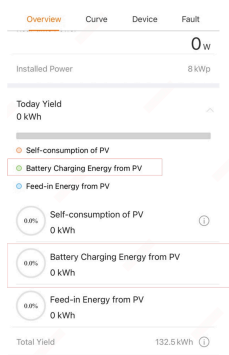

2. Tap **Device**, Tap **Battery**, Battery parameters then be consulted.

Device information : Basic information about the battery device.

Other information : Basic information about battery operating parameters.

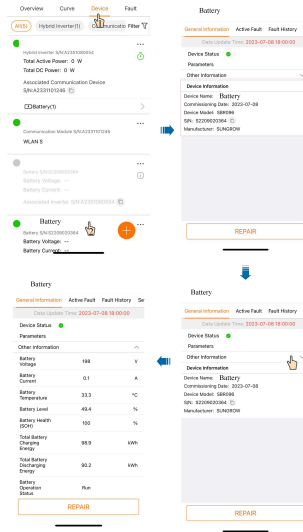

Viewing Battery information on iSolarcloud Web

1. Log in to the iSolarCloud Web, tap **Overview**, the battery charging energy from PV then be displayed.

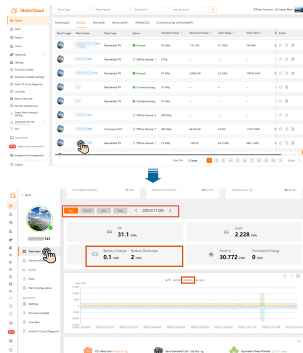

2. Tap **Device information**, Tap **Battery**, Battery parameters then be consulted.

Device information : Basic information about the battery device.

Other information : Basic information about battery operating parameters.

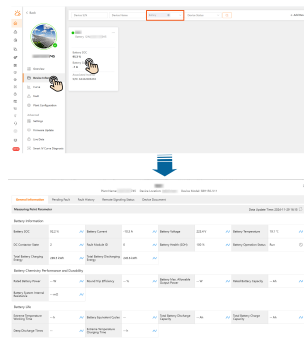

8 Battery Augmentation



If you have requirements of battery augmentation, please contact battery installers for professional support.

Battery charging and discharging may take a long time. So before adding a new battery (module) , please finish charging and discharging the battery system on site remotely. Please follow the instructions as outlined below:

Follow steps 1-6 to remotely charge and discharge the batteries at the plant site to ensure that the SOC of these batteries is consistent with that of the new modules to be added.

The following conditions must be met to use the battery augmentation function:

- The iSolarCloud App version should be V2.1.6.20230731 or later.
- The battery version should be V12 or later.
- The inverter model should be SHRS series and the version should be later than Sunstone-H_01011.02.27(LCD).

WARNING

Before adding a new battery (module), be sure to charge/discharge the on-site battery system via iSolarCloud App. After the settings are completed successfully, battery charging/discharging will start automatically, until the SOC of the battery on site is the same as that of the battery to be added. Otherwise, the battery system may not work normally after the new battery is added, and the problems arising therefrom will not be covered by warranty.

step 1 Open the iSolarCloud App and tap **Local Access** at the bottom left of the login screen.

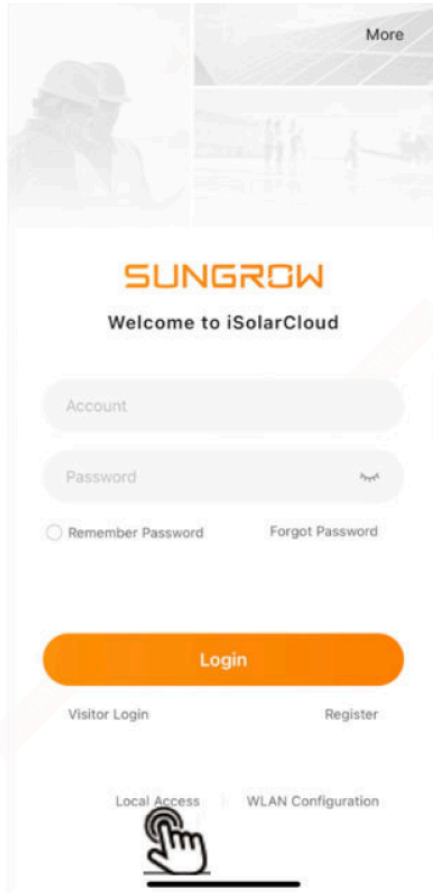

step 2 On the **Scan to Connect** screen, point your camera at the QR code on the device's enclosure, then wait for the connection to complete.

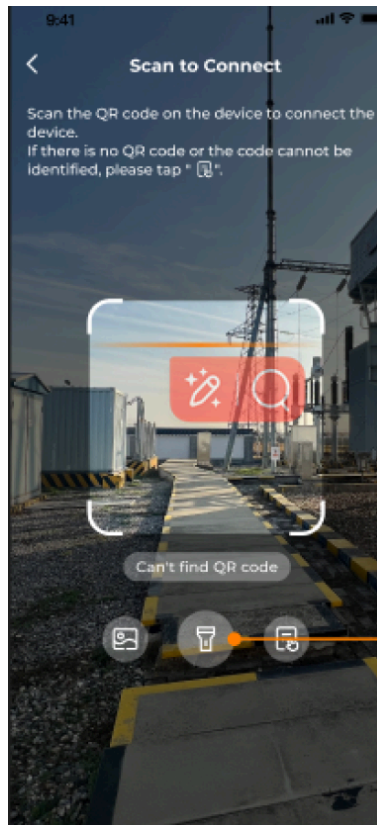

- a. If the QR code is missing or the scan fails, tap  to go to Manual Connection and connect to the device manually.

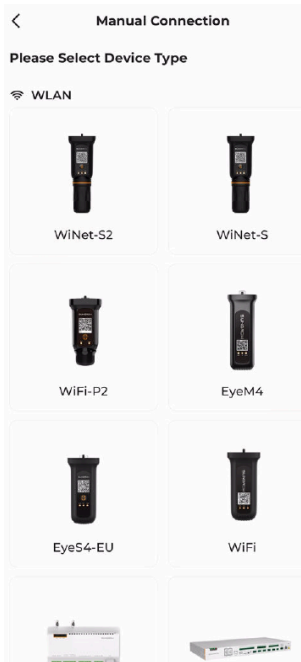

- b. Select the target device. The system will proceed to Bluetooth Connection. Wait for the connection to complete. If no Bluetooth device is found, disconnect and reconnect the communication module, then try again.

step 3 Enter your account name and password on the Identity Verification screen, and then tap Verify. The default account name and password are listed below. Please change your password as soon as possible to keep your account secure.

step 4 Navigate to **More**→**Battery Management** .

step 5 Tap **Battery Augmentation**.

step 6 Obtain the SOC of new battery modules by scanning the QR code or manually entering device

S/N. Tap  to enter the code scanning screen. Scan the QR code on the battery module to obtain the SOC.

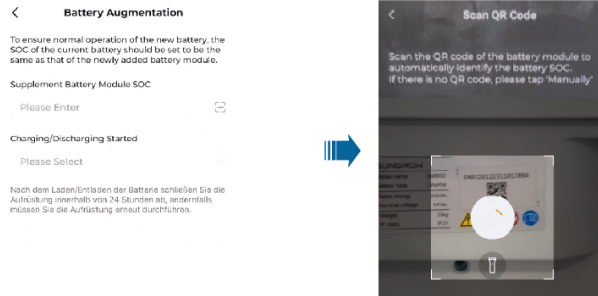

 If there is no QR code, please tap **Manually**.

step 7 Tap **Charging/Discharging Started** to set the start time, and tap **Execute Now** to wait for the charge and discharge to complete.

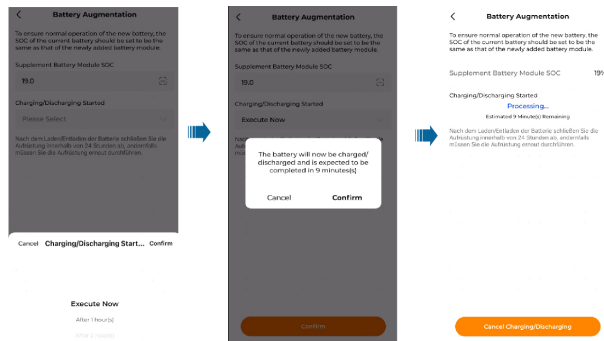

step 8 Power down the system following the commissioning steps. Install the new battery after the system is completely powered down.

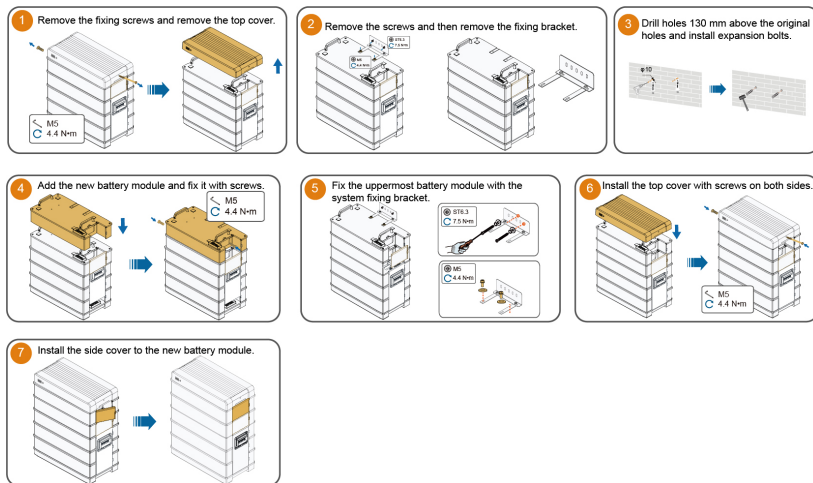

step 9 Check the battery base to ensure that the battery is placed steadily after the new battery module has been added. Reactivate the battery referring to Chapter Commissioning in the battery user manual and check whether the battery operates properly. Restore the battery waterproof cover, awning (if there is), etc.

-- End

9 Troubleshooting and Maintenance

9.1 Troubleshooting

In the event of any fault occurring to the battery system, the fault information can be viewed on the iSolarCloud App. If the hybrid inverter is equipped with an LCD display, you may check the fault information on the screen. Fault codes and the corresponding troubleshooting methods are listed in the table below.

Fault Name	Fault Code	Corrective Measure
	703, 711, 712, 715, 717	<ol style="list-style-type: none">1. Generally, the fault will disappear by itself within 20 min.2. In the event of continual and frequent occurrence of this fault, please switch off the battery system, and contact the installer or manufacturer to check whether the inverter is damaged.3. Please contact the installer or the manufacturer if the issue persists for a long time. Switch off the battery system immediately if the SOC drops below 3% to avoid damage caused by battery over-discharge.
Battery fault	707, 733	<ol style="list-style-type: none">1. Check whether there is a heat source near the battery system, and measure the ambient temperature. The operating temperature range of the battery system is 0 to 55°C for charging, and -20 to 55°C for discharging. Please check whether the ambient temperature or the battery temperature goes beyond this range. In case the battery is placed near a heat source or in an unventilated environment, or the ambient temperature is too high, please improve the installation environment for the battery system.2. Please contact the installer or the manufacturer if the issue persists for a long time. Switch off the battery system immediately if the SOC drops below 3% to avoid damage caused by battery over-discharge.

Fault Name	Fault Code	Corrective Measure
	708, 734	<ol style="list-style-type: none"> 1. The operating temperature range of the battery system is 0 to 55°C for charging, and -20 to 55°C for discharging. Please check whether the ambient temperature or the battery temperature falls below this range. In case the ambient temperature is too low, please improve the installation environment for the battery system. 2. Please contact the installer or the manufacturer if the issue persists for a long time. Switch off the battery system immediately if the SOC drops below 3% to avoid damage caused by battery over-discharge.
	714	<ol style="list-style-type: none"> 1. Check whether the communication cable between the battery and the inverter is incorrectly or loosely connected. 2. Replace the communication cable if the problem is not resolved. 3. Please contact the installer or the manufacturer if the issue persists for a long time. Switch off the battery system immediately if the SOC drops below 3% to avoid damage caused by battery over-discharge.
	732	<ol style="list-style-type: none"> 1. Please contact the installer or manufacturer to upgrade the hybrid inverter, WiNet, and battery software to the latest version. 2. Please contact the installer or the manufacturer if the issue persists for a long time. Switch off the battery system immediately if the SOC drops below 3% to avoid damage caused by battery over-discharge.
	735, 736, 737	<ol style="list-style-type: none"> 1. Generally, the battery will return to normal automatically; 2. If the problem is not resolved, switch off the battery system, and restart it after 5 minutes. 3. Please contact the installer or the manufacturer if the issue persists for a long time. Switch off the battery system immediately if the SOC drops below 3% to avoid damage caused by battery over-discharge.

Fault Name	Fault Code	Corrective Measure
	739	<ol style="list-style-type: none"> 1. Switch off the battery system, and restart it after 5 minutes. 2. Please contact the installer or the manufacturer if the issue persists for a long time. Switch off the battery system immediately if the SOC drops below 3% to avoid damage caused by battery over-discharge.
	740	<ol style="list-style-type: none"> 1. Check whether the client RACK is incorrectly or loosely connected. Switch off the battery, and restart it after 5 minutes. 2. Please contact the installer or the manufacturer if the issue persists for a long time. Switch off the battery system immediately if the SOC drops below 3% to avoid damage caused by battery over-discharge.
	741	<ol style="list-style-type: none"> 1. Please contact the installer or manufacturer to upgrade the hybrid inverter, WiNet, and battery software to the latest version. 2. If the problem is not resolved, please check whether the system configuration is correct (SUNGROW single-phase hybrid inverter used with battery system consisting of 2~6 PACKs; SUNGROW three-phase hybrid inverter used with battery system consisting of 3~8 PACKs). 3. Please contact the installer or the manufacturer if the issue persists for a long time. Switch off the battery system immediately if the SOC drops below 3% to avoid damage caused by battery over-discharge.
	742	<ol style="list-style-type: none"> 1. Please check whether the power cables are connected in inverse or poorly connected. 2. Please contact the installer or the manufacturer if the issue persists for a long time. Switch off the battery system immediately if the SOC drops below 3% to avoid damage caused by battery over-discharge.

Fault Name	Fault Code	Corrective Measure
	743, 744, 745	<ol style="list-style-type: none"> 1. Generally, the battery will return to normal automatically; 2. If the problem is not resolved, please upgrade the battery software. 3. Please contact the installer or the manufacturer if the issue persists for a long time. Switch off the battery system immediately if the SOC drops below 3% to avoid damage caused by battery over-discharge.
	746	<ol style="list-style-type: none"> 1. Please contact the installer or manufacturer to upgrade the hybrid inverter, WiNet, and battery software to the latest version. 2. If the problem is not resolved, please contact the installer to change the order of PACKs and re-install the battery system. 3. Please contact the installer or the manufacturer if the issue persists for a long time. Switch off the battery system immediately if the SOC drops below 3% to avoid damage caused by battery over-discharge.
	747	<ol style="list-style-type: none"> 1. Switch off the battery system, and restart it after 5 minutes. 2. If the problem is not resolved, please upgrade the battery software. 3. Please contact the installer or the manufacturer if the issue persists for a long time. Switch off the battery system immediately if the SOC drops below 3% to avoid damage caused by battery over-discharge.

Fault Name	Fault Code	Corrective Measure
	833	<ol style="list-style-type: none"> 1. Please contact the installer or manufacturer to upgrade the hybrid inverter, WiNet, and battery software to the latest version. 2. If the problem is not resolved, please check whether the system configuration is correct (SUNGROW single-phase hybrid inverter used with battery system consisting of 2~6 PACKs; SUNGROW three-phase hybrid inverter used with battery system consisting of 3~8 PACKs). 3. If the problem is not resolved, please contact the installer to change the order of PACKs and re-install the battery system. 4. Please contact the installer or the manufacturer if the issue persists for a long time. Switch off the battery system immediately if the SOC drops below 3% to avoid damage caused by battery over-discharge.
	932, 939, 964	<ol style="list-style-type: none"> 1. Generally, the battery will return to normal automatically. 2. Please contact the installer or the manufacturer if the issue remains unresolved for a long term. Turn off the battery immediately if the SOC drops below 3% to avoid damage caused by battery over-discharge..
Battery alarm	937, 941, 942	<ol style="list-style-type: none"> 1. Generally, the battery will return to normal automatically. 2. If the problem is not resolved, please upgrade the battery software. 3. Please contact the installer or the manufacturer if the issue remains unresolved for a long term. Turn off the battery immediately if the SOC drops below 3% to avoid damage caused by battery over-discharge..

Fault Name	Fault Code	Corrective Measure
	933	<p>1. Check whether there is a heat source near the battery system, and measure the ambient temperature. The operating temperature range of the battery system is 0 to 55°C for charging, and -20 to 55°C for discharging. Please check whether the ambient temperature or the battery temperature goes beyond this range. In case the battery is placed near a heat source or in an unventilated environment, or the ambient temperature is too high, please improve the installation environment for the battery system.</p> <p>2. Please contact the installer or the manufacturer if the issue persists for a long time. Switch off the battery system immediately if the SOC drops below 3% to avoid damage caused by battery over-discharge.</p>
	934	<p>1. The operating temperature range of the battery system is 0 to 55°C for charging, and -20 to 55°C for discharging. Please check whether the ambient temperature or the battery temperature falls below this range. In case the ambient temperature is too low, please improve the installation environment for the battery system.</p> <p>2. Please contact the installer or the manufacturer if the issue persists for a long time. Switch off the battery system immediately if the SOC drops below 3% to avoid damage caused by battery over-discharge.</p>
	935	<p>1. Generally, the battery will return to normal automatically.</p> <p>2. If the problem is not resolved, switch off the battery system, and restart it after 5 minutes.</p> <p>3. Please contact the installer or the manufacturer if the issue remains unresolved for a long term. Turn off the battery immediately if the SOC drops below 3% to avoid damage caused by battery over-discharge..</p>

9.2 Maintenance

NOTICE

When adding new battery modules for capacity expansion, please contact SUNGROW and follow the instruction released by SUNGROW. Otherwise, the system performance will be affected or even cannot operate properly.

Below is the recommended maintenance cycle. The actual maintenance cycle should be adjusted according to the specific installation environment of this product.

The power station scale, installation location and on-site environment affect the maintenance cycle of this product. In sandy or dusty environments, it is necessary to shorten the maintenance cycle and increase the frequency of maintenance.

Maintenance performed once a year

Inspection item	Inspection method
Battery module status and cleanliness	<p>Check the following items. In case of nonconformity, take corrective actions immediately:</p> <ul style="list-style-type: none"> • Check the battery module and and switchgear for damage or deformation. • Check the battery system for abnormal noise during operation. • Check whether the temperature inside the battery system is too high.
Warning sign	Check whether the warning sign and label are legible and dirty. If necessary, clean them.
Wire and cable	Check whether the switch gear and hybrid inverter are reliable connection.
Corrosion	Check the outside of the battery system for oxidation or rust.

Maintenance performed once every six months

Inspection item	Inspection method
Switch gear and battery module	<p>Check the following items. In case of nonconformity, take corrective actions immediately:</p> <ul style="list-style-type: none"> • Check whether there are flammable objects around the battery module. • Check whether the battery module is reliably fixed on the wall, and whether any fixing point is corroded. • Check the switch gear and battery module for damage, paint peeling, oxidation, etc.
Wire and cable layout	<p>The inspection must not be carried out until all internal devices of the battery module are powered off! In case of nonconformity found in inspection, take corrective actions immediately:</p> <ul style="list-style-type: none"> • Check the cable layout for short circuit and compliance with the specifications. If case of any abnormality, take corrective actions immediately. • Check the battery module for internal seepage of water. • Check whether the cables are loose, and tighten them according to the aforesaid torque.
Grounding	Check whether the grounding is correct.
Function inspection	Check whether the current, voltage and temperature in the isolar cloud app of the battery system are within the operating ranges.

10 Appendix

10.1 Technical Data

table 10-1 Technical parameters of high voltage LFP battery(SBR064 / SBR096 / SBR128 / SBR160).

Parameters	SBR064*	SBR096	SBR128	SBR160
System Data				
Battery Type	LiFePO4 Prismatic Cell			
Battery Module	3.2 kWh, 33 kg			
Energy (usable) **	6.4 kWh	9.6 kWh	12.8 kWh	16 kWh
Nominal voltage	128 V	192 V	256 V	320 V
Operating voltage	108V-146 V	162 V– 219 V	216 V– 292 V	270 V– 365 V
Rated DC power	3.84 kW	5.76 kW	7.68 kW	9.60 kW
Max. charge/discharge power	4.38 kW	6.57 kW	8.76 kW	10.95 kW
Max. charging / discharging current: continuous***	30 A			
Depth of Discharge	Max. 100% DOD(settable)			
Short circuit current	3500A			
Display	SOC indicator, Status indicator			
Communication interface	CAN			
Protection				
Over / under voltage protection	Yes			
Over current protection	Yes			
Over / under temperature protection	Yes			
DC breaker	Yes			

Parameters	SBR064*	SBR096	SBR128	SBR160
General Data				
Dimensions (W*H*D)	625 * 545 * 330 mm	625 * 545 * 330 mm	625 * 675 * 330 mm	625 * 805 * 330 mm
Weight	89kg	114kg	147kg	180kg
Installation location	Indoor / Outdoor			
Mounting method	Floor stand			
Operating temperature	Charge: 0 to 55°C Discharge: -20 to 55°C			
Degree of protection	IP55			
Allowable relative humidity range	0% to 95% no condensing			
Max. operating altitude	2000 m			
Cooling method	Natural convection			
Warranty	Please consult the local SUNGROW service team			
Expansion adaptation	Up to 4 units in parallel (need extra Combiner box)			

* SBR064 consists of 2 battery modules and 1 empty module.

** Test conditions: 25°C, 100% depth of discharge (DOD), 0.2C charge & discharge.

*** The maximum charging/discharging current of SBR064 is 20A when used with SHRT series inverter.

table 10-2 Technical parameters of high voltage LFP battery(SBR192 / SBR224 / SBR256).

Parameters	SBR192	SBR224	SBR256
System Data			
Battery Type	LiFePO4 Prismatic Cell		
Battery Module	3.2 kWh, 33 kg		
Energy (usable)**	19.2 kWh	22.4 kWh	25.6 kWh
Nominal voltage	384 V	448 V	512 V
Operating voltage	324 V – 438 V	378 V – 511 V	432 V – 584 V
Rated DC power	11.52 kW	13.44 kW	15.36 kW
Max. charge/discharge power	13.14 kW	15.33 kW	17.52 kW

Parameters	SBR192	SBR224	SBR256
Max. charging / discharging current: continuous		30 A	
Depth of Discharge		Max. 100% DOD(settable)	
Short circuit current		3500A	
Display		SOC indicator, Status indicator	
Communication interface		CAN	
Protection			
Over / under voltage protection		Yes	
Over current protection		Yes	
Over / under temperature protection		Yes	
DC breaker		Yes	
General Data			
Dimensions (W*H*D)	625 * 935 * 330 mm	625 * 1065 * 330 mm	625 * 1195 * 330 mm
Weight	213kg	246kg	279kg
Installation location		Indoor / Outdoor	
Mounting method		Floor stand	
Operating temperature		Charge: 0 to 55°C Discharge: -20 to 55°C	
Degree of protection		IP55	
Allowable relative humidity range		0% to 95% no condensing	
Max. operating altitude		2000 m	
Cooling method		Natural convection	
Warranty		Please consult the local SUNGROW service team	
Expansion adaptation		Up to 4 units in parallel (need extra Combiner box)	

** Test conditions: 25°C, 100% depth of discharge (DOD), 0.2C charge & discharge.

10.2 FAQs

10.2.1 Battery Not Charging

1. Please wait 5~10 minutes for data refresh of iSolarCloud App.

2. If the problem persists, try charging the battery by enabling force mode. If the battery can be charged now, please contact the hybrid inverter installer or manufacturer.
3. Check if the current battery SOC is the same as the set SOC upper limit of the hybrid inverter. Once the battery SOC reaches or goes beyond the SOC upper limit, the battery cannot be charged (please set the value to 50~100 as needed).
4. If the problem is still not resolved, please check the system for any faults and take countermeasures according to the fault code.
5. If the problem is still not resolved, check whether the ambient temperature is near or below 0°C. Switch off the battery in the event of the temperature falling below 0°C, and restart and charge it when the temperature rises up to over 5°C.
6. If the problem persists, check whether there is a heat source near the battery and whether the ambient temperature goes higher than 55°C. Switch off the battery in the event of the temperature exceeding 55°C, and restart and charge it when the temperature falls below 40°C.
7. Contact the installer or manufacturer if the problem can still not be resolved. Switch off the battery immediately once the SOC drops below 3%.

10.2.2 Battery Not Discharging

1. Please wait 5-10 minutes for data refresh of iSolarCloud App.
2. If the problem persists, try discharging the battery by enabling force mode. If the battery can discharge now, please contact the hybrid inverter installer or manufacturer.
3. Check if the current battery SOC is the same as the set SOC lower limit of the hybrid inverter. Once the battery SOC reaches or falls below the SOC lower limit, the battery will not discharge (please set the value to 5-50 as needed).
4. If the problem is still not resolved, please check the system for any faults and take countermeasures according to the fault code.
5. Check whether there is a heat source near the battery and whether the ambient temperature goes higher than 55°C. Switch off the battery in the case of the temperature exceeding 55°C, and restart and discharge it when the temperature falls below 40°C.
6. Contact the installer or manufacturer if the problem can still not be resolved. Switch off the battery immediately once the SOC drops below 3%.

10.2.3 SOC Jump

1. Occasional occurrence of SOC jump is considered to be a normal phenomenon, which does not affect the normal operation of the system.
2. In case the SOC jump issue occurs frequently, please contact the installer or manufacturer.

10.2.4 Battery Upgrade

1. Please contact the installer or manufacturer for iSolarCloud upgrade, if needed.
2. If the iSolarCloud is updated, please upgrade the software of the hybrid inverter, the communication module, and the battery at the same time. Otherwise, there may be problems arising from the mismatch of software versions.
3. Please contact the installer or manufacturer immediately in case of anything abnormal during or after the upgrade.

10.3 Quality Assurance

When product faults occur during the warranty period, SUNGROW will provide free service or replace the product with a new one.

Evidence

During the warranty period, the customer shall provide the product purchase invoice and date. In addition, the trademark on the product shall be undamaged and legible. Otherwise, SUNGROW has the right to refuse to honor the quality guarantee.

Conditions

- After replacement, unqualified products shall be processed by SUNGROW.
- The customer shall give SUNGROW a reasonable period to repair the faulty device.

Exclusion of Liability

In the following circumstances, SUNGROW has the right to refuse to honor the quality guarantee:

- The free warranty period for the whole machine/components has expired.
- The device is damaged during transport.
- The device is incorrectly installed, refitted, or used.

- The device operates in harsh conditions beyond those described in this manual.
- The fault or damage is caused by installation, repairs, modification, or disassembly performed by a service provider or personnel not from SUNGROW.
- The fault or damage is caused by the use of non-standard or non-SUNGROW components or software.
- The installation and use range are beyond stipulations of relevant international standards.
- The damage is caused by unexpected natural factors.

For faulty products in any of above cases, if the customer requests maintenance, paid maintenance service may be provided based on the judgment of SUNGROW.



Product data such as product dimensions are subject to change without prior notice. The latest documentation from SUNGROW should take precedence in case of any deviation.

10.4 Contact Information

In case of questions about this product, please contact us.

We need the following information to provide you the best assistance:

- Model of the device
- Serial number of the device
- Fault code/name
- Brief description of the problem

For detailed contact information, please visit: <https://en.SUNGROWpower.com/contactUS>

SUNGROW

Sungrow Power Supply Co., Ltd.
www.sungrowpower.com