

# User Manual

## AC Charger

AC22E-01



# All Rights Reserved

## All Rights Reserved

No part of this document can be reproduced in any form or by any means without the prior written permission of Sungrow Power Supply Co., Ltd (hereinafter "SUNGROW").

## Trademarks

**SUNGROW** and other Sungrow trademarks used in this manual are owned by SUNGROW.

All other trademarks or registered trademarks mentioned in this manual are owned by their respective owners.

## Software Licenses

- It is prohibited to use data contained in firmware or software developed by SUNGROW, in part or in full, for commercial purposes by any means.
- It is prohibited to perform reverse engineering, cracking, or any other operations that compromise the original program design of the software developed by SUNGROW.

## Privacy Protection

- Information contained in this manual is the private property of Sungrow Power Supply Co., Ltd. No part of this manual may be transmitted in any form without the prior written permission of Sunlight Power Co., Ltd. Internal reproduction is allowed only for product evaluation or other appropriate purposes.
- We declare that the network account and password data stored in the equipment system are only used for remote control and monitoring of the equipment and will not be transmitted to any third-party data platform without the user's permission.

## Disposal

After the service life of the charger ends, please dispose of it in accordance with the applicable electrical waste disposal act at the installation location. It can also be returned to Sungrow Power Supply Co., Ltd., but the relevant expenses shall be borne by your party.

# About This Manual

## Declaration

To ensure the safe use of the product, please read through the below information carefully:

1. The warranty period agreed for this product is subject to the contract.
2. This manual is intended for personnel who are responsible for product installation and other work on the product. Users must have certain electrical and mechanical expertise, and be familiar with the electrical and mechanical schematics and the characteristics of electronic components. SUNGROW shall not be held liable for any personal injury or financial loss arising from the installation operation carried out by non-qualified personnel or not in compliance with the safety instructions specified in this manual.
3. The content of this manual, including the pictures, marks, and symbols used herein, is all owned by SUNGROW. No part of this manual may be reproduced by any non-internal staff without the prior written authorization of SUNGROW.
4. The manual may be updated and revised from time to time, however, there still might be slight deviations from the real product or errors. In such cases, the actual product you have purchased should take precedence. You can find the latest version of the user manual on the company website, or reach your sales for it.
5. To ensure the safety of the installation personnel, the product, and the system, follow strictly the safety instructions specified in this manual when installing the product. SUNGROW shall not be held liable for any personal injury or financial loss arising from failure to follow the instructions specified in this manual.
6. If maintenance on or alteration to this product is needed, please contact SUNGROW customer service in advance. The copyright of this user manual belongs to SUNGROW, and any rights not expressly granted are reserved. The content of the manual is subject to change without notice and the actual up-to-date product shall prevail.

## How to Use This Manual

This manual mainly provides relevant information about the product and gives instructions on the safe operation, installation, electrical connection, and routine inspection of the product.

### Valid for

Product Model	Product Aliases
AC22E-01	Charger, "the device/product"

### Target Group

This manual is intended for qualified technical persons who are responsible for the installation, operation, and maintenance of the product, as well as people who use the

product for charging. Installation must only be performed by qualified technical persons, and qualified technical persons must be:

- Have certain electrical wiring, electronic, and mechanical expertise, and be familiar with electrical and mechanical schematics;
- Have received professional training in the installation and commissioning of electrical equipment;
- Be able to respond quickly and effectively to dangers or emergencies that may occur during the process of installation and commissioning;
- Be familiar with applicable local standards and specifications of the country/region where the project is located;
- Read through this manual carefully and have a good understanding of the relevant safety instructions.

## **EMC**

In some cases, even if the equipment is in accordance with the standard emission limits, it can have an impact in certain application areas (some sensitive equipment is placed in the same location; the equipment is installed close to a radio or TV receiver), and the operator is obliged to take appropriate action to correct this situation.

## **How to Use This Manual**

Read through this manual carefully before using the product, and keep it properly in an easy-to-reach place. The manual may be updated and revised from time to time, however, there still might be slight deviations from the real product or errors. In such cases, the actual product you have purchased should take precedence. You can also download the latest version of the user manual at [support.sungrowpower.com](http://support.sungrowpower.com).

## **Symbols in the Manual**

To ensure the safe and efficient use of the product, the manual provides relevant safety information, which are highlighted using relevant symbols. Symbols that may appear in this manual are listed below, but not all. Please read carefully for better use of this manual.

### **DANGER**

Indicates an imminently hazardous situation which, if not avoided, will result in death or serious injury.

### **WARNING**

Indicates a moderately hazardous situation which, if not avoided, will result in death or serious injury.

### **CAUTION**

Indicates a slightly hazardous situation which, if not avoided, may result in minor or moderate injury.

## NOTICE

Indicates a potential hazard which, if not avoided, will result in device malfunction or property damage.



Indicates supplementary information, emphasis on specific points, or tips related to the use of the product that might help to solve your problems or save your time.

# 1 Product Description

## 1.1 Introduction

The AC22E-01 charger (hereinafter "charger") is used for AC charging of electric vehicles (EVs) and can be either wall-mounted or pole-mounted, with the following advantages:

### Ease of Use

EV drivers can start and stop charging via RFID charge card or App. When the vehicle is fully charged, the charging will stop. The charger also supports plug&play, which means the charging starts automatically as soon as the charging connector is plugged into the vehicle.

### Smart and Easy Management

In addition to the LED lights on the charger that indicate charging status, EV drivers can visualize and control the charging session remotely via iEnergyCharge.

### Sustainability

With an IP65 rating, the charger is water and dust proof, allowing for outdoor use and maintenance.

### Declaration of Conformity

The manufacturer Sungrow Power Supply Co., Ltd, China hereby confirms that the product AC22E-01 complies with the essential requirements and other relevant provisions of Directives 2014/35/EU.

## 1.2 Model

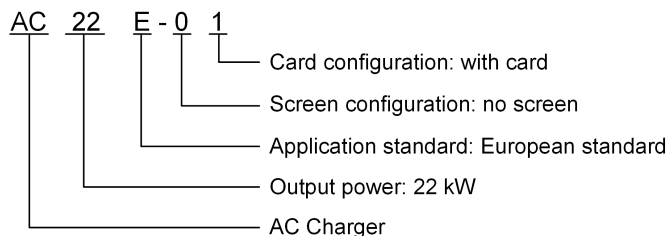

### 1.3 Appearance and Dimensions

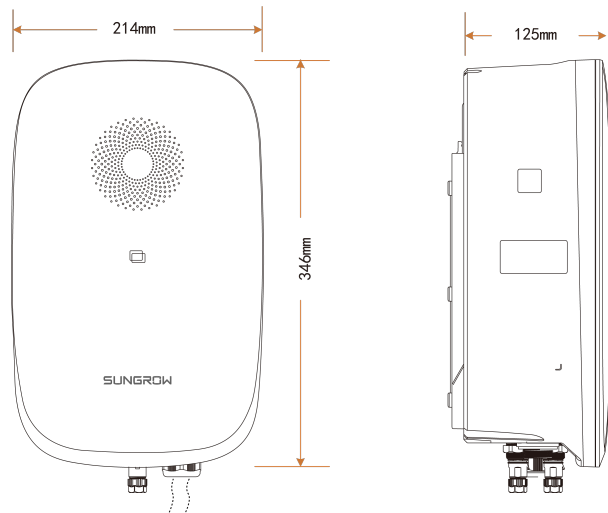

Figure 1-1 Appearance and dimensions

### 1.4 LED Signals

Table 1-1 LED Signals

LED Signal	Description
Blue indicator is steady on	Charger standby or charging is complete without drawing the charging plug
Blue indicator flashes, on for 0.5s and off for 0.5s	The charger connector is connected to the vehicle
Blue indicator breathes	Vehicle charging
Blue indicator flashes, on for 0.2s and off for 0.2s, 5 times	RFID charge card used
Red indicator is steady on	Fault occurs (check the fault type through App)
Indicator flashes rapidly 5 times, accompanied by a 1.5s beep from the buzzer	Reset local access password to the default <sup>(1)</sup> Turn on Wi-Fi hotspot <sup>(2)</sup>

LED Signal	Description
Indicator flashes rapidly 3 times, accompanied by a 0.5s beep from the buzzer	Turn off Wi-Fi hotspot <sup>(3)</sup>

(1) There are two methods to reset the local access password to the default (when charging connectors are not plugged):

- **Use the Restart button:** Press and hold the Restart button until the buzzer sounds.
- **Use the RFID card:** Hold the charge card against the card reader for over 5s.

(2) There are two methods to turn on the Wi-Fi hotspot (when charging connectors are not plugged):

- **Use the Restart button:** Press the Restart button quickly 3 times in a row within 5s.
- **Use the RFID card:** Tap the card on the card reader 3 times or more within 8s.

(3) There are two methods to turn off the Wi-Fi hotspot (when charging connectors are not plugged):

- **Use the Restart button:** Press the Restart button quickly 4 times in a row within 5s.
- **Use the RFID card:** Tap the card on the card reader 4 times or more within 8s.

## 1.5 Terminal Description

Electrical terminals are located at the bottom of the charger. The 4G terminal is located on the right side of the charger.



The charger is equipped with Wi-Fi (built-in), 4G, Ethernet, and RS485 interfaces, and only authorized users can access these ports.

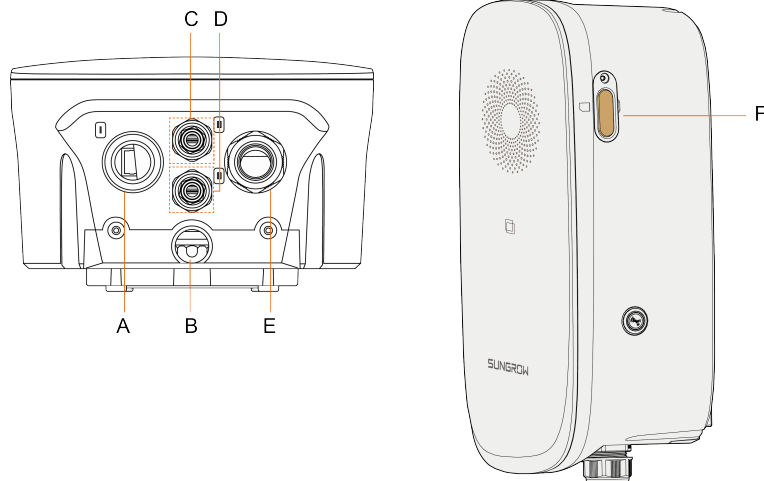

Figure 1-2 Terminal Diagram

**Table 1-2** Label Explanation

Label	Explanation
A	Network communication
B	AC input from the utility grid
C	RS485 Port 1 for connection to the Hybrid Inverter
D	RS485 Port 2 for connection to the Smart Energy Meter
E	Charging cable output (preinstalled)
F	4G communication

**NOTICE**

**Extension cable sets are not allowed to be used.**

## 1.6 System Topology

### Stand-alone EV Charger

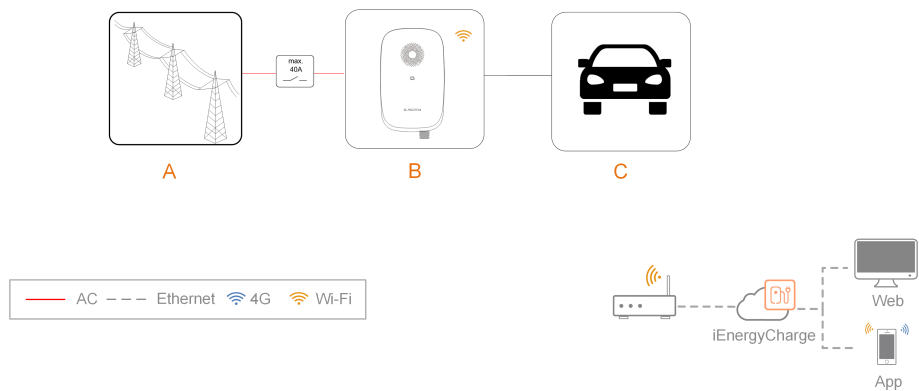
**Figure 1-3** System topology diagram of EV charger

Position	Description	Note
A	Utility grid	TN-C, TN-S, TN-C-S.
B	Charger	AC22E-01
C	Electric vehicle	-

### Solar-Storage-Charging Solution

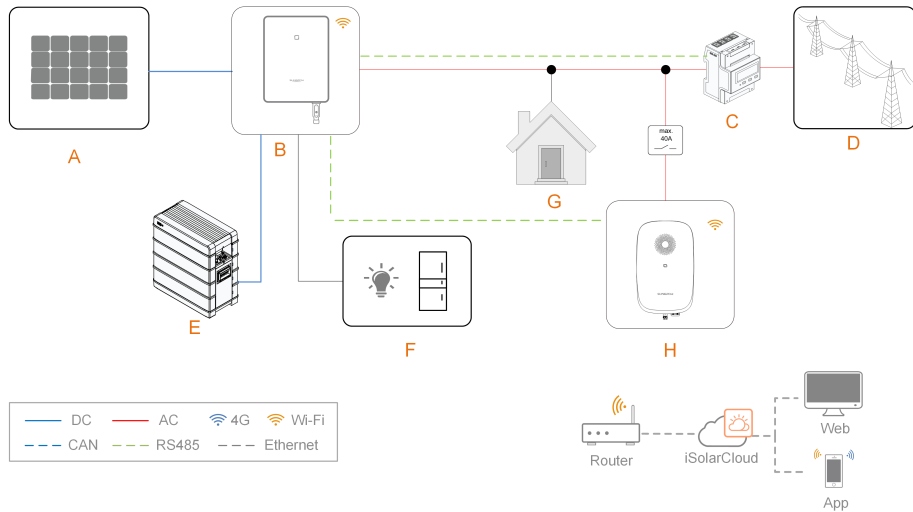

**Figure 1-4** System topology diagram of the solar-storage-charging solution

Position	Description	Note
A	PV strings	Compatible with monocrystalline silicon, polycrystalline silicon, and thin-film modules without grounding.
B	Inverter	SUNGROW's 3-phase inverter (SHRT).
C	Energy Meter	Meter cupboard with power distribution system.
D	Utility grid	TN, TN-C-S, TN-S, TN-C. The type of grid grounding system depends on local regulations.
E	Battery	A Li-ion battery.
F	Backup loads	Protected house loads directly connected to the inverter.
G	Normal loads	Non-protected house loads. They will be disconnected in case of grid failure.
H	Charger	AC22E-01



For SUNGROW's solar-storage-EV charging solution, please refer to user manuals of related inverters.

## 2 Installation

### ⚠ WARNING

- Respect all local standards and requirements during mechanical installation.
- Do not operate the device in temperature outside its operating range of -30°C to 50°C (-22°F to 122°F).

### ⚠ CAUTION

Any damage or malfunction with the charger caused by negligence or improper use will not be eligible for service and replacement under the warranty.

## 2.1 Installation Requirements

### Location Requirements

Select an optimal mounting location for safe operation, long service life and expected performance.

- The charger with protection rating IP65 can be installed both indoors and outdoors.
- The charger should be installed at a place where the LED signals can be easily seen, and is convenient for electrical connection, operation, and maintenance.

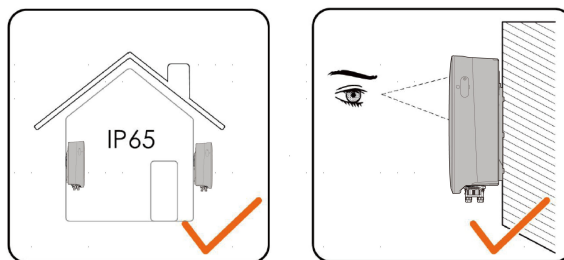

### Environment Requirements

- There must be no flammable hazards or ignition risks.
- The mounting location must be inaccessible to children.
- Please consult SUNGROW before installing chargers outdoors in areas prone to salt damage, which mainly are coastal areas within 500 meters of the coast. The sedimentation amount of salt spray is correlated to the characteristics of the seawater, sea winds, precipitation, air humidity, topography, and forest coverage in the adjacent sea areas, and there are substantial differences between different coastal areas.
- The ambient temperature and relative humidity must meet the following requirements.

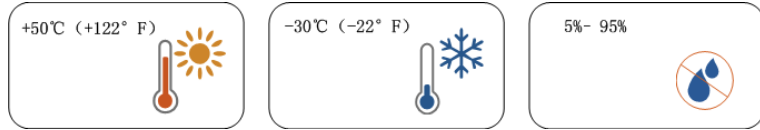

**i** If the environment temperature exceeds 40°C, the charger will be derated.

- Avoid exposure to direct sunlight, rainwater and snow.
- The charger should be well-ventilated for good air circulation.
- It is suggested to install the device in a place with shelter, so as to prevent it from getting impacted by direct sunlight or severe weather (e.g., snow, rain, and lightning). The device will derate in high temperatures for self-protection. If installed in a place directly exposed to sunlight, as the temperature rises, the device may witness power reduction.

### Carrier Requirements

The mounting structure where the charger is installed must comply with local/national standards and guidelines.

Ensure that the installation surface is solid enough to bear 4.5 times the weight of the charger and is suitable for the dimensions of the charger.

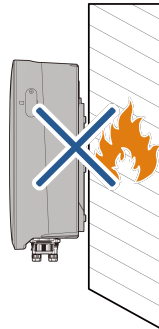

### Angle Requirements

It is recommended to install the charger vertically, or at a forward or backward inclination of 10° to the vertical. Do not install the charger horizontally or at large forward or backward inclination angles to the vertical, nor keep it upside down.

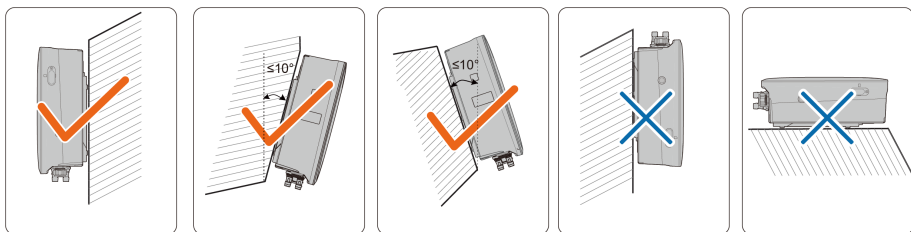

## 2.2 Unpacking and Inspection



After receiving the product, check whether the appearance and structural parts of the device are damaged, and check whether the packing list is consistent with the actual ordered product. If there are problems, do not install the device and contact your distributor first. If the problem persists, contact SUNGROW in time.

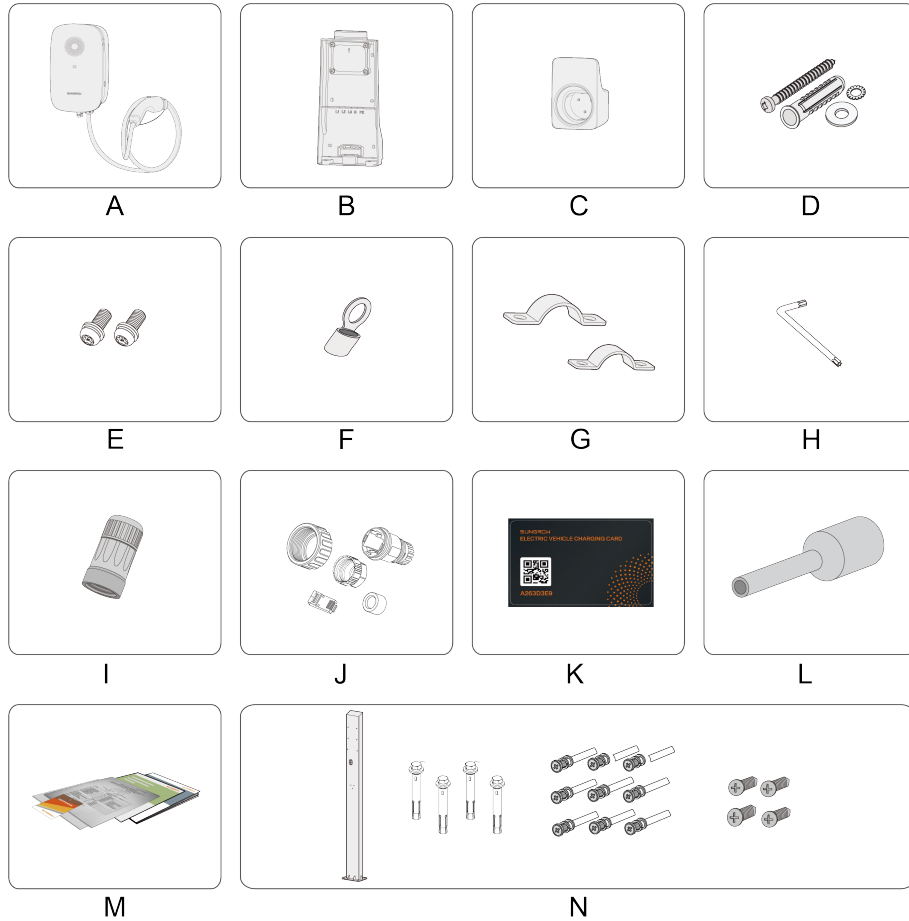

**Table 2-1** Label Descriptions

Item	Name	Quantity
A	AC-Charger	1
B	Backplate	1
C	Bracket	1
D	Expansion screw	9

Item	Name	Quantity
E	Hexlobular socket pan head tamper proof screws	2
F	OT terminals	OT8-4: 5 OT6-4: 5
G	Cable fastener	Three-phase:1 Single-phase:1
H	L-shaped wrench □T20□	1
I	LAN connector set	1
J	RJ45 protection sleeve	2
K	RFID card	2
L	Euro terminals	2
M	Documents	1
N	Pole accessories (optional)	1(purchase separately)



If your RFID M1 Card is lost, please contact SUNGROW customer service to post-register it.

## 2.3 Installation Tools



**Table 2-2** Label Descriptions

Item	Name	Specification
A	Marker	-
B	Multimeter:	≥600 Vdc
C	Cable drill tool	Ø6, Ø12
D	Wire stripper	
E	Hydraulic clamp	2.5-10mm <sup>2</sup>
F	Hot air blower	-
G	Cross screwdriver	M4
H	Rubber hammer	-
I	Pan head tamper proof wrench	-
J	RJ45 crimping tool	-

## 2.4 Electrical Connection

### 2.4.1 Circuit Diagram

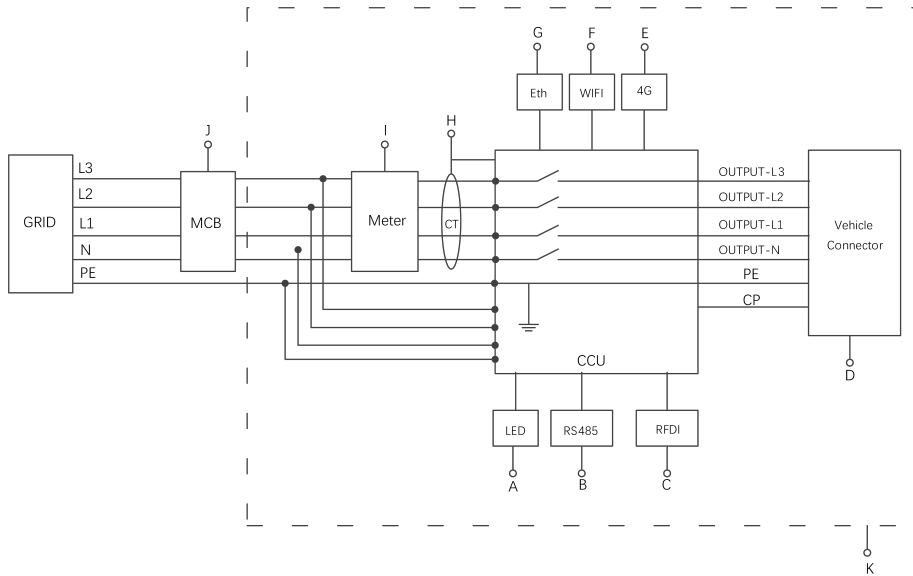

Figure 2-1 Circuit diagram

Table 2-3 Label Descriptions

Label	Description	Remarks
A	LED lights	The LED lights that indicates the status of the charger
B	RS485	Reserved for external communication
C	RFID	Start by swiping card
D	Vehicle connector	Connect the target vehicle
E	4G	External communication
F	WIFI	External communication
G	Eth	Connect the router
H	CT	-
I	Electricity meter	-
J	MCB	Type A residual-current device . AC22E-01: 40 A/4P AC400 V with a rated residual current of 30 mA

Label	Description	Remarks
K	The charger	-

### NOTICE

The charger already integrates a DC residual-current device (RCD) with a rated residual current of 6 mA. However, the charger also requires a type A RCD of 30 mA to operate. Each charger in the system must be individually connected to the utility grid through an RCD and a miniature circuit breaker.

## 2.4.2 AC Cable Connection

### Prerequisite

Table 2-4 Cable Requirements

Type	Cable Diameter	Cable Cross-section
Outdoor 5-core copper wire cable	14.5 mm–19.5 mm	5 × 6 mm <sup>2</sup> / 10 mm <sup>2</sup>

### 2.4.2.1 Three-phase cable Connection

**Step 1** Loosen the M4 hexlobular socket pan head tamper proof screws that secure the backplate and dismantle the backplate. (M4 screws, torque: 1.2 N·m)

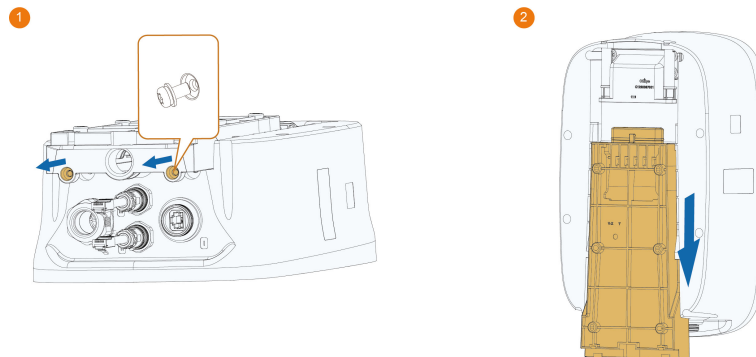

If the backplate cannot be dismantled, check if the screws on the top of the charger are tightened.

**Step 2** Use the cross screwdriver to loosen the screws of backplate. (M4 screws, torque: 1.2 N·m)

**Step 3** Push up the back cover plate with hand.

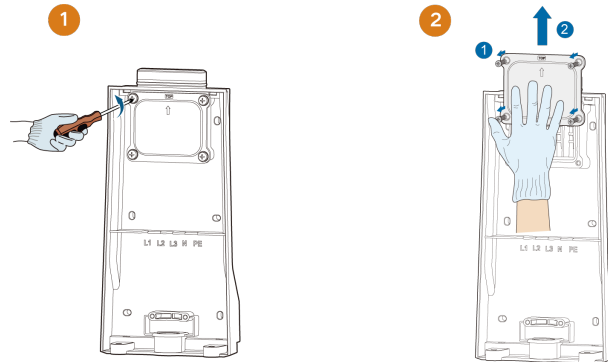

**Step 4** Plug the cable into the port of the power supply which is in the middle.

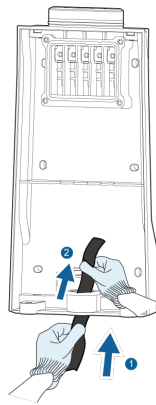

**Step 5** Adjust the cable to a suitable length, and strip off the insulation of the cable to prepare for cable connection terminals.

- a. Strip off the insulation from the end of each wire.
- b. Insert the copper core of the stripped end of the wire into the copper lug.
- c. Tighten the copper lug using a hydraulic plier.
- d. Select a heat-shrink tubing that matches the diameter of the wire.

The length of the tubing should be about 2 cm longer than the length of the copper lug's wire tube.

- e. Place the heat-shrink tubing on the copper lug until it completely covers the copper lug's wire hole.
- f. Activate heat-shrink tubing using a hot air blower.

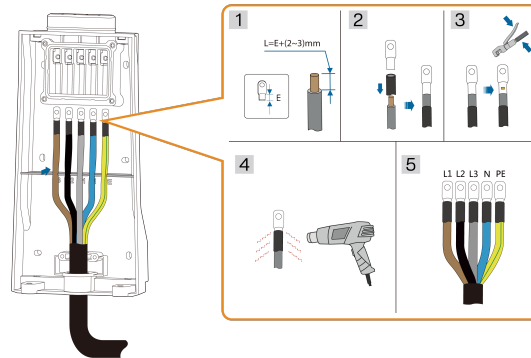

Color	Terminal
Brown	L1
Black	L2
Gray	L3
Blue	N
Yellow-green	PE

**⚠ DANGER**

If L1,L2,L3,N,PE are connected incorrectly, it will not only damage the machine, but also create a potential shock hazard .

**⚠ DANGER**

In the TT, TN-C and TN-S system, make sure that the ground cable is connected reliably. Otherwise, it may cause electric shock.

**Step 6** Install the sealing ring.

- a. Insert the sealing ring into the each wire.
- b. Plug the wire into the hole, and insert the sealing ring into the hole.



The ring face of the OT terminal faces upward.

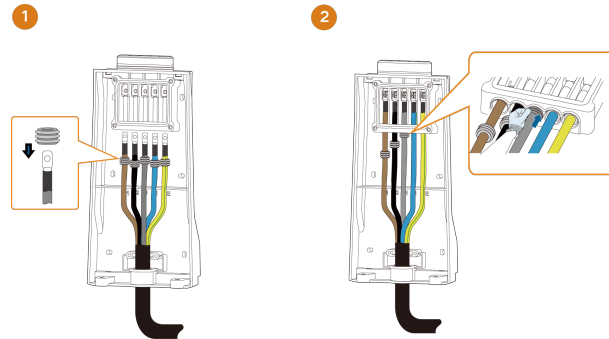

**Step 7** Connect each crimped terminal (OT5.5-4) and tighten them using a M4 screwdriver. (Torque: 1.2 N·m)

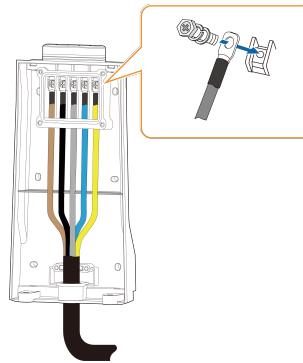

### **WARNING**

Please make sure that the OT terminal is firmly crimped, otherwise the temperature may rise and cause fire inside the device. If the OT terminal is not crimped or not firmly crimped, SUNGROW shall not be held liable for any property damage arising therefrom.

### **NOTICE**

For 10mm<sup>2</sup> AC cable, OT8-4 is required.

**Step 8** Put the back cover plate back in place and tighten the screws to secure it. (M4 screws, torque: 1.2 N·m)

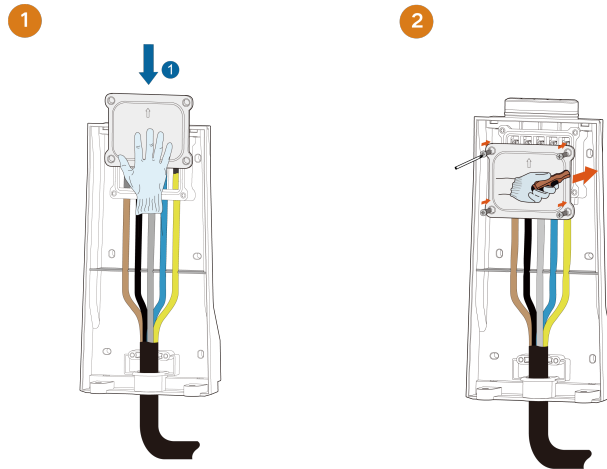

**Step 9** Put the cable fastener in place and tighten the screws to secure it. (M4 screws, torque: 1.2 N·m)

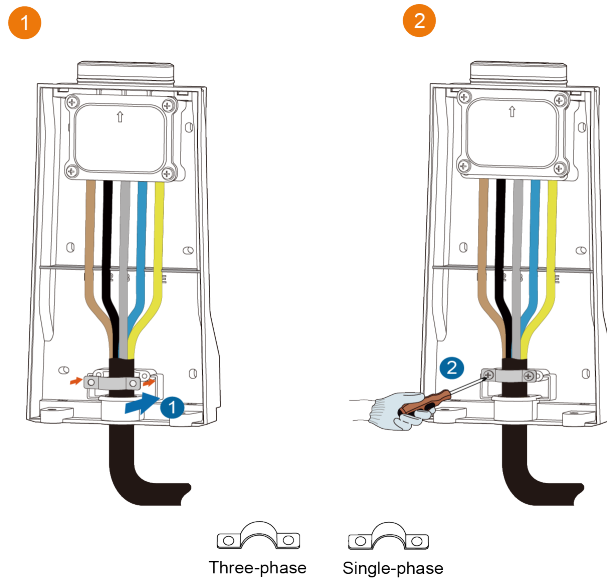

--End

#### 2.4.2.2 Single-Phase Cable Connection

**Step 1** Loosen the M4 hexlobular socket pan head tamper proof screws that secure the backplate and dismantle the backplate. (M4 screws, torque: 1.2 N·m)

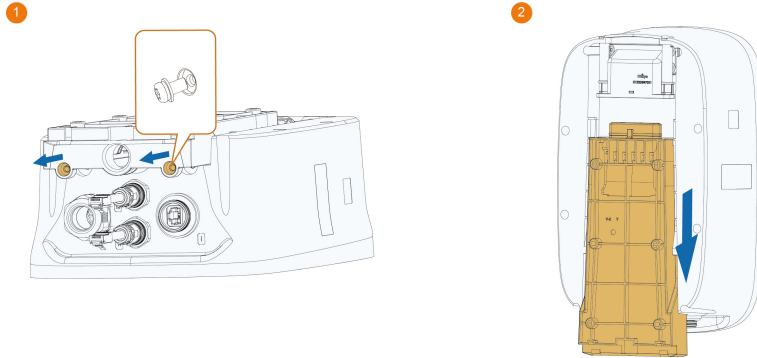

If the backplate cannot be dismantled, check if the screws on the top of the charger are tightened.

**Step 2** Use the cross screwdriver to loosen the screws of backplate. (M4 screws, torque: 1.2 N·m)

**Step 3** Push up the back cover plate with hand.

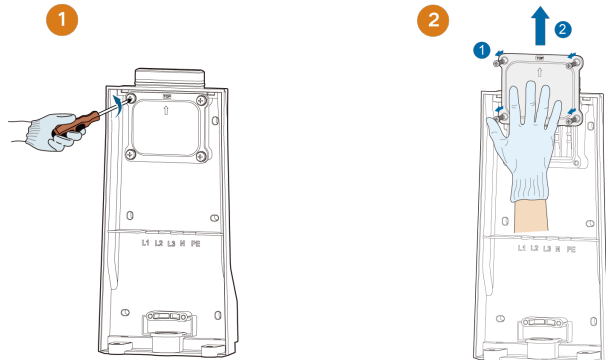

**Step 4** Plug the cable into the port of the power supply which is in the middle.

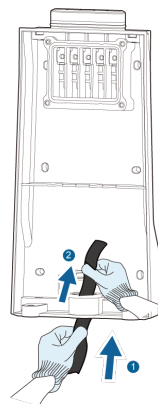

**Step 5** Adjust the cable to a suitable length, and strip off the insulation of the cable to prepare for cable connection terminals.

- a. Strip off the insulation from the end of each wire.
- b. Insert the copper core of the stripped end of the wire into the copper lug.

- c. Tighten the copper lug using a hydraulic plier.
- d. Select a heat-shrink tubing that matches the diameter of the wire.
 

The length of the tubing should be about 2 cm longer than the length of the copper lug's wire tube.
- e. Place the heat-shrink tubing on the copper lug until it completely covers the copper lug's wire hole.
- f. Activate heat-shrink tubing using a hot air blower.

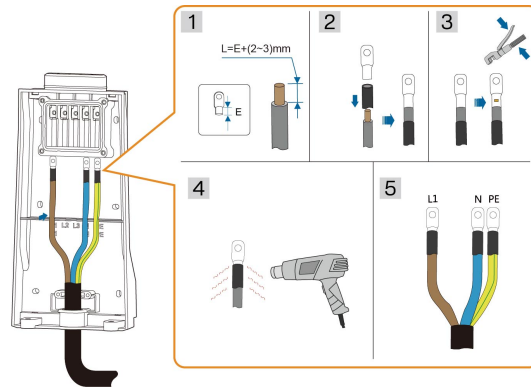

**⚠ DANGER**

If L,N,PE are connected incorrectly, it will not only damage the machine, but also create a potential shock hazard .

**⚠ DANGER**

In the TT, TN-C and TN-S system, make sure that the ground cable is connected reliably. Otherwise, it may cause electric shock.

**Step 6** Install the sealing ring.

- a. Insert the sealing ring into the each wire.
- b. Plug the wire into the hole, and insert the sealing ring into the hole.

**i** The ring face of the OT terminal faces upward.

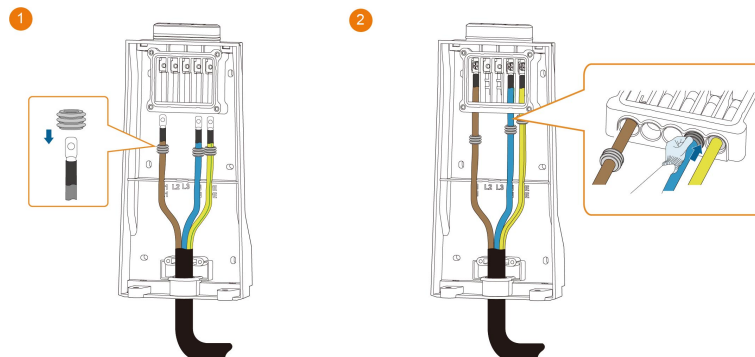

**Step 7** Connect each crimped terminal (OT5.5-4) and tighten them using a M4 screwdriver.  
(Torque: 1.2 N·m)

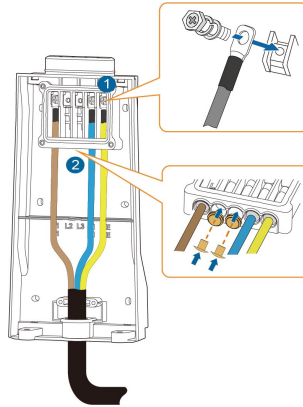

### ⚠ WARNING

Please make sure that the OT terminal is firmly crimped, otherwise the temperature may rise and cause fire inside the device. If the OT terminal is not crimped or not firmly crimped, SUNGROW shall not be held liable for any property damage arising therefrom.

### NOTICE

For 10mm<sup>2</sup> AC cable, OT8-4 is required.

**Step 8** Put the back cover plate back in place and tighten the screws to secure it. (M4 screws, torque: 1.2 N·m)

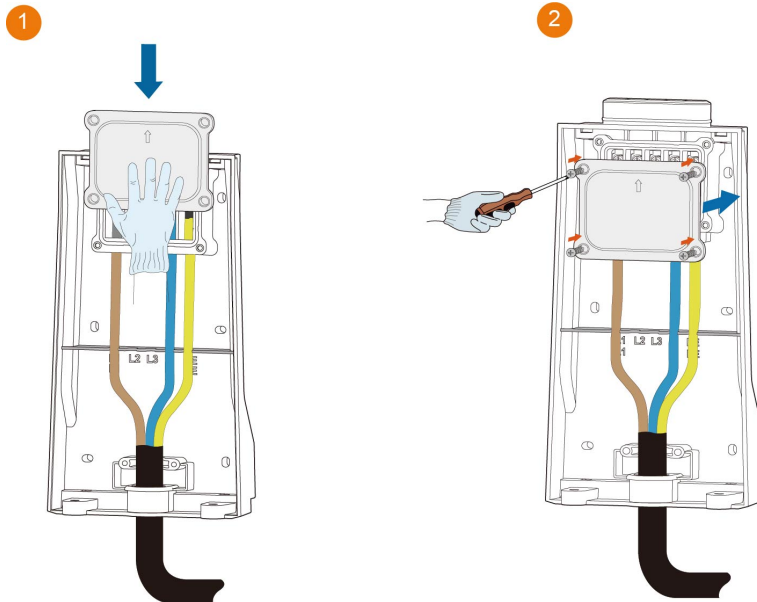

**Step 9** Put the cable fastener in place and tighten the screws to secure it. (M4 screws, torque: 1.2 N·m)

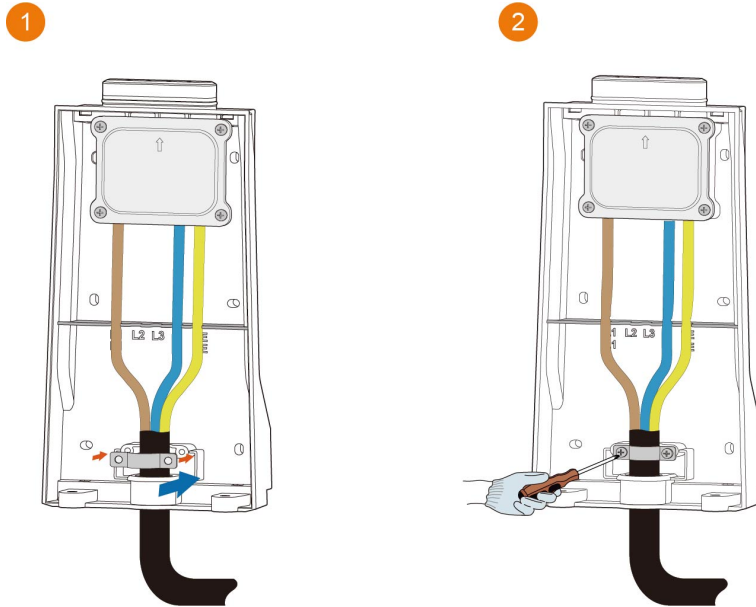

**--End**

(If rear wiring is selected) Before installing the backplate, choose one of the two reserved openings on the back for cable access.

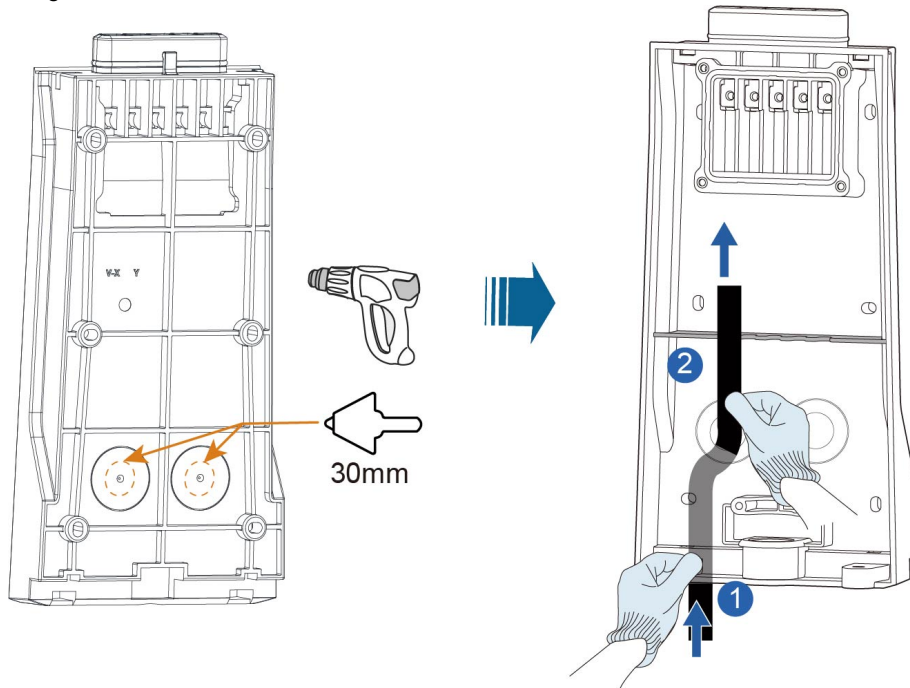

### 2.4.3 Ethernet Communication Connection

**Step 1** (Optional) Strip the insulation layer of the communication cable with an Ethernet wire stripper, and lead the corresponding signal cables out. Insert the stripped communication cable into the RJ45 plug in the correct order, and crimp it with a crimper.

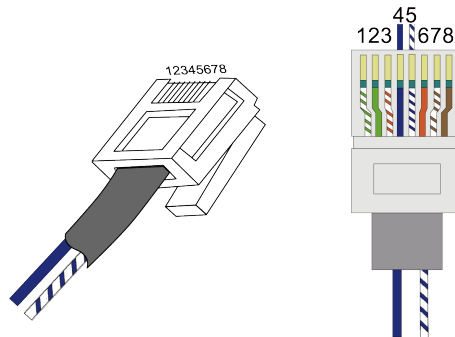

**Step 2** Thread the network cable through the swivel nut and gasket. Afterwards, route the cable into the opening of the sealing. Finally, insert the cable through the housing.

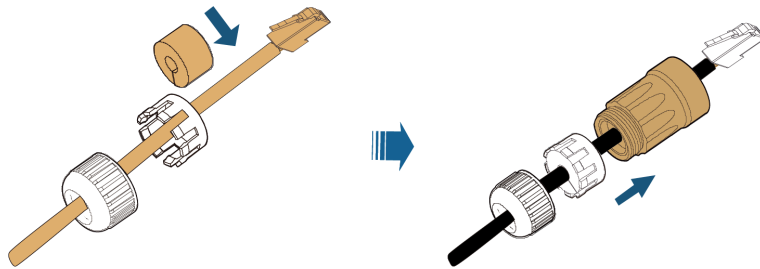

**Step 3** Unscrew the waterproof lid from the Network communication terminal.

**Step 4** Insert the LAN connector into Network communication terminal on the bottom of the Charger. Pull cables outwards to confirm whether they are fastened firmly, then tighten the swivel nut with appropriate torque.

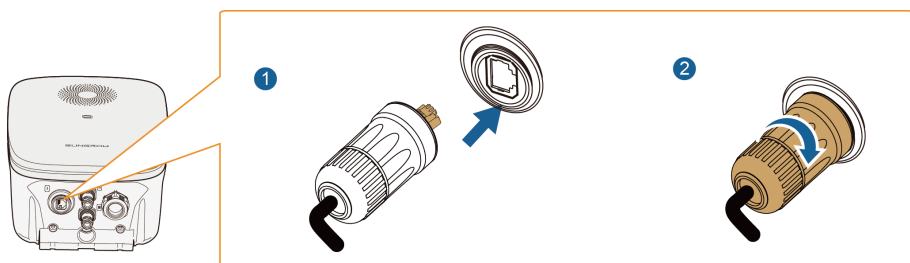

--End

### 2.4.4 RS485 Communication Connection

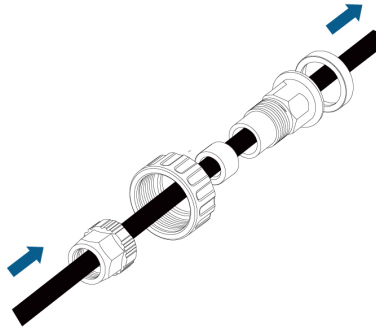
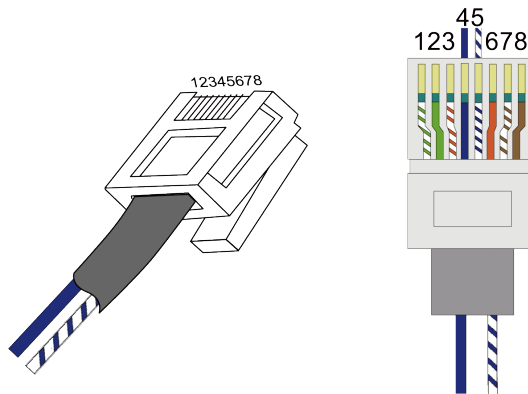

Figure 2-2 RJ45 components

**Step 1** Crimp the Ethernet cable using a crimping tool.



Ensure that the blue wire and the blue-white wire is correctly crimped. The blue wire (PIN 4) connects to 485B, and the blue-white wire (PIN 5) connects to 485A.



**Step 2** Insert the RJ45 connector to the RJ45 jack.

**Step 3** Install seals for the Ethernet cable in sequence.



Ensure that the cable is secured.

**Step 4** Connect the charger to the ALM ( Adaptive Load Management) meter or the SHRT hybrid inverter.

#### **WARNING**

When installing the meter, ensure that the current transformer or voltage cables is correctly installed. Otherwise, the charger may charge at the maximum power, possibly causing the general circuit breaker to trip.

- Stand-alone EV charger: Connect to the ALM meter

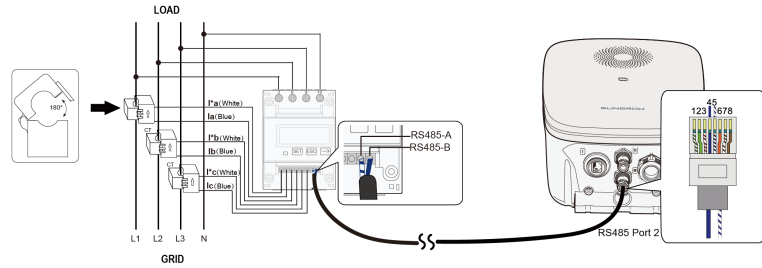

**Figure 2-3** Connect to a Smart Energy Meter (DTSU666, when used alone with ALM)

- Combo 1.0 solution (PV+ESS+EV charger): Connect to the SHRT hybrid inverter.

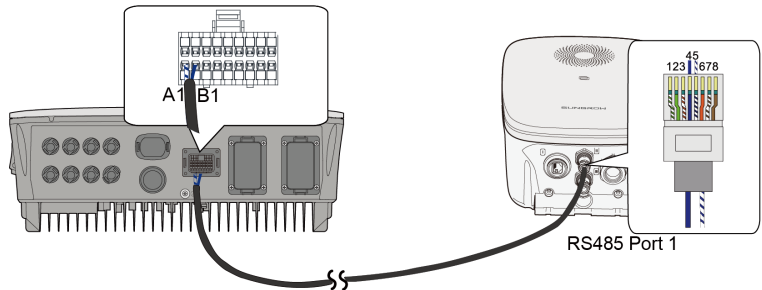

**Figure 2-4** Connect to an inverter (only SHRT series is supported)

**i** For connecting the charger to the inverter, an RS485 Cat5, Cat6, Cat5e, or Cat6a cable is recommended. Do not use Cat7 cable.

--End

### 2.4.5 Protective Device Connection

In Netherlands and Italy. The following protective devices must be used when installing chargers: NDB5E-80 2P, NDB5E-80 4P.

Application Scope and Purpose:

- Short circuit protection
- Overload protection
- Over-voltage/under-voltage protection
- Three-phase unbalance protection
- Isolation
- Electrical energy measurement
- Remote opening and closing
- Timed opening and closing
- Current leakage protection

The connection method is as follows (using NDB5E-80 4P as an example):

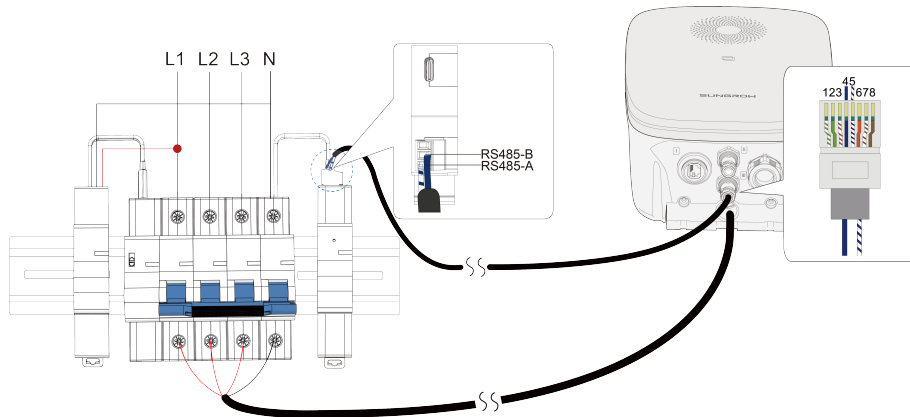
**Table 2-5** Electrical parameters

Product Model	NDB5E-80 2P	NDB5E-80 4P
Applicable Standards	IEC61009-1 / GB/T16917.1	
Number of product poles	2P (one protection pole, N pole can be opened and closed)	4P (three protection poles, N pole can be opened and closed)
Rated working voltage $U_e$ (V)	AC230/240	AC400/415
Rated insulation voltage $U_i$ (V)	500	
Rated impulse withstand voltage $U_{imp}$ (kV)	4	
Rated current $I_n$ (A)	63	
Rated short-circuit breaking capacity $I_{cn}$ (kA Effective value)	6	
Rated operating short-circuit breaking capacity $I_{cs}$ (kA Effective value)	6	
Instantaneous tripping characteristics	Type C (5~10) $I_n$	
Power frequency withstand voltage	AC2500V 50Hz 1min	
Reference calibration temperature (°C)	30	

Product Model	NDB5E-80 2P	NDB5E-80 4P
Rated frequency (Hz)	50	
Utilization category	Category A	
Installation category	II , III	
Electrical life (times)	6000	
Mechanical life (times)	10000	
Residual tripping current type	Type A	
Rated residual action current	30mA	
Connection capacity	Connection terminal: Tunnel type connection terminal; Terminal connection area: Minimum 1mm <sup>2</sup> , up to 25mm <sup>2</sup> ; Terminal screw: M5; Rated torque: 2.0N·m	
Isolating function	Practical breaking indication The green identification in the inspection window indicates that the contact is in the disconnection position	
Mode of inlet wire	Upper inlet wire	

### NOTICE

- **The installer has the responsibility to determine whether these devices offer adequate electrical protection, comply with local regulations, or need to be supplemented with additional protective devices such as an RCD or MCB.**
- **Only the NDB5E-802P/NDB5E-802P purchased from Sungrow is approved for use with the AC22E-01. The use of any third-party or non-Sungrow-sourced protective device is not recommended.**

## 2.5 Wall-Mounting

Install the charger on the wall using the provided wall-mounting bracket and expansion screw sets.



The load-bearing capacity of the installation carrier must be at least 4.5 times the weight of the charger.

**Step 1** Install the backplate and the charging cable bracket .

- a. Hold the cardboard and backplate in the desired position on the wall and mark the positions of the drill holes.

**NOTICE**

**Before drilling the hole for the backplate, locate and avoid water pipes and electrical wires in the wall.**

- b. Drill holes at the marked positions using a hammer drill. (Diameter: 6 mm; depth: 45 mm)
- c. Insert the dowel into the holes.
- d. Place the backplate on the wall and tighten the screws using a screwdriver to secure the backplate(M4 screws, torque: 1.2 N·m).

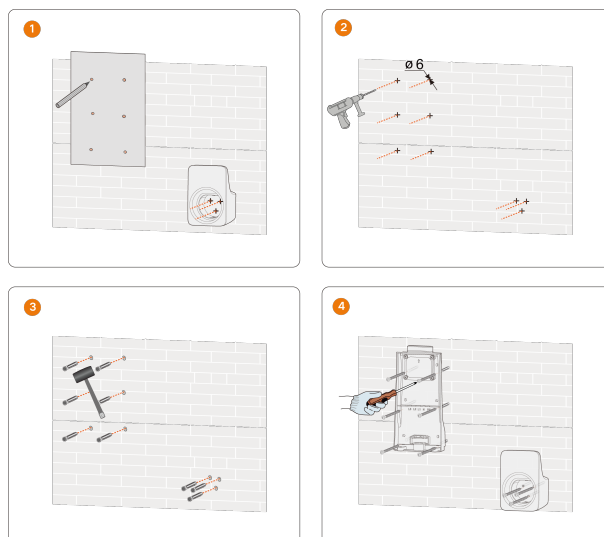

It is recommended that the charging cable bracket be positioned at the lower right side of the charger, about 20 cm away from the charger. The distance shall be adjusted according to the actual situation.

**Step 2** Connect the AC cable. Please refer to [2.4.2.1 Three-phase cable Connection](#).**Step 3** Mount the charger.

- a. Hang the charger onto the backplate, and hear "Click", the charger is install in place.

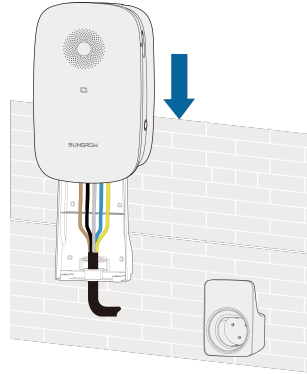

- b. Secure the upper charger with M4 screw for plates. (Torque: 1.2 N·m).
- c. Secure the lower charger with M4 hexlobular socket pan head tamper proof screws. (Torque: 1.2 N·m).

1

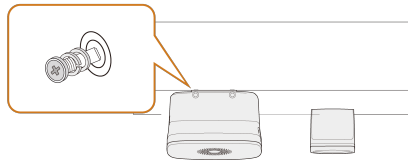

2

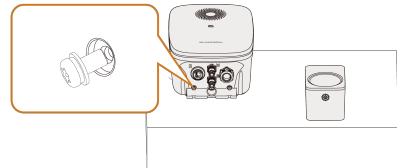

#### Step 4 SIM card installation.

- If you choose to connect to the internet via 4G, you will need to install a SIM card in the device. Please purchase the SIM card yourself.
- It is recommended to use a SIM card with a data plan of 500MB per month. Once the monthly data is exhausted, the device's internet connection will be disconnected. Please purchase additional data in a timely manner to restore the network connection.

i

- a. Remove the screws of the cover plate of card slot by using cross screwdriver in the top right corner of the charger.
- b. Pry the cover plate of card slot by using slotted screwdriver.
- c. Insert the sim card into the card slot in the direction of the Micro SIM card icon.
- d. Re-lock the cover plate of card slot .

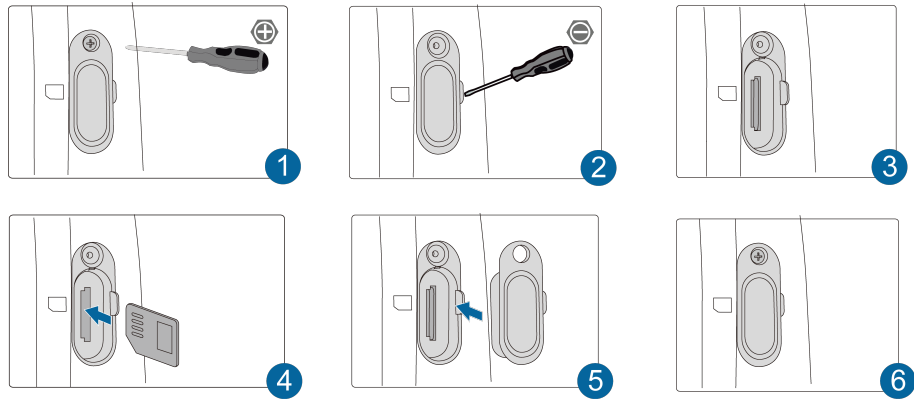

--End

## 2.6 Pole-Mounting (Optional)



It is recommended to install the pole on a solid support surface (such as concrete or tarmac). If conditions do not permit, please install the foundation first, and then install the mounting pole.

### 2.6.1 Foundation Building

The base should be 100 mm above the ground, and the exterior dimensions of the front, back, left, and right side columns should be greater than 100 mm. Ensure that there are openings for cables.

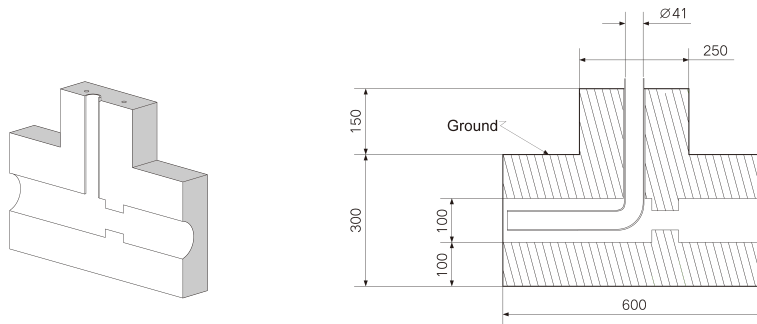
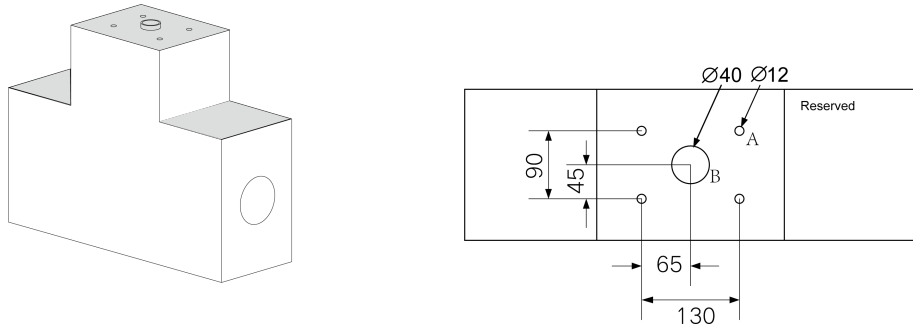

Figure 2-5 Front view (unit: mm)



**Figure 2-6** Top view (unit: mm)

### NOTICE

- A:** Expansion screw: 4×M8×80 mm; hole diameter: 12mm; depth: 100mm  
**B:** Cable hole diameter: 40mm

## 2.6.2 Pole Installation

### Step 1 Connect the AC cable.

- a. Remove the cover plate on the back of the pole using a cross screwdriver.
- b. Lead the AC cable through the bottom into the pole.
- c. Grab the AC cable when it reaches the cover plate, and take out the end of the AC cable from the AC cable outlet.
- d. Pull the AC cable out to an appropriate length and close the cover plate.



If RS485 communication is required, connect the RS485 cables following the same steps as described previously.

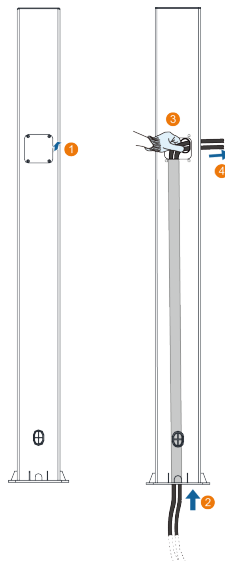

### Step 2 Mount the charger.

- a. Place the pole on a solid and flat surface, and mark the positions of the drill holes.
- b. Drill holes at the marked positions using a hammer drill. (Diameter: 12 mm; depth: 85 mm)
- c. Insert the dowel into the holes.
- d. Tighten the expansion screw using a screwdriver.

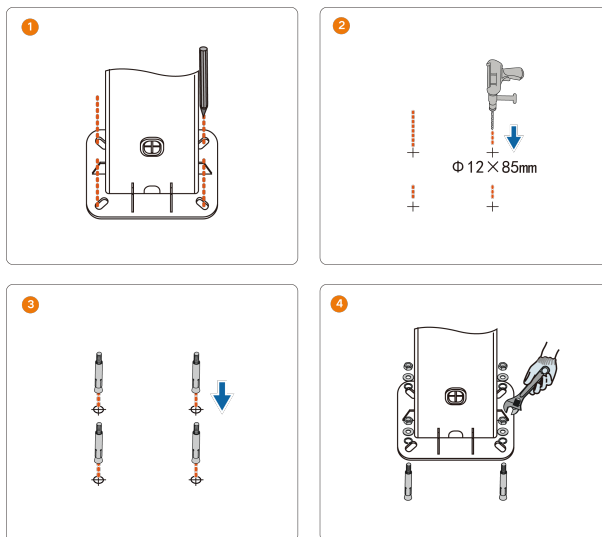

- e. Check whether the pole is firmly installed.

### Step 3 Install the backplate and the charging cable bracket.

- a. Align the holes in the backplate with the holes drilled in the pole, and secure the backplate to the pole with screws.
- b. Align the holes in the bracket with the holes drilled in the pole, and secure the bracket to the pole with screws.
- c. Check whether the backplate and the charging cable bracket are firmly installed.

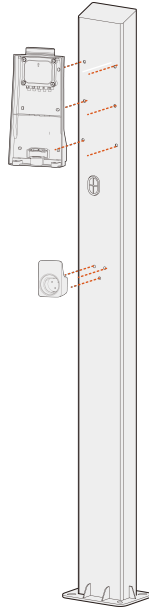
**Step 4** Connect the AC cable.

Please refer to [2.4.2.1 Three-phase cable Connection](#)

**Step 5** Install the charger.

- a. Hang the charger onto the backplate, and hear "Click", the charger is install in place.
- b. Secure the upper charger with M4 screw for plates. (Torque: 1.2 N·m).
- c. Secure the lower charger with M4 hexlobular socket pan head tamper proof screws. (Torque: 1.2 N·m).
- d. Check whether the charger is correctly installed on the pole.

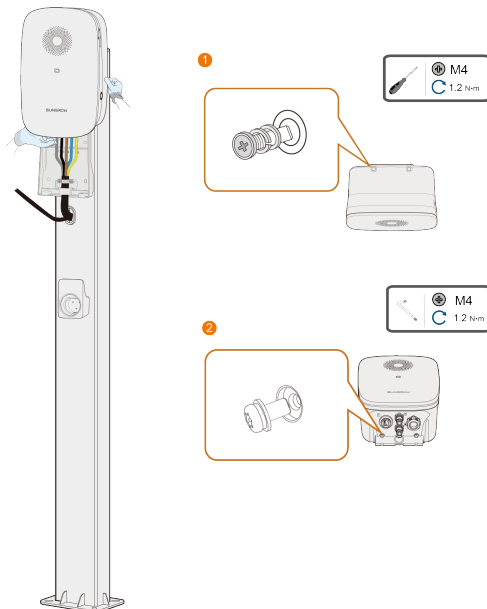

**Step 6** Connect the Ethernet communication cable.

Please refer to [2.4.3 Ethernet Communication Connection](#)

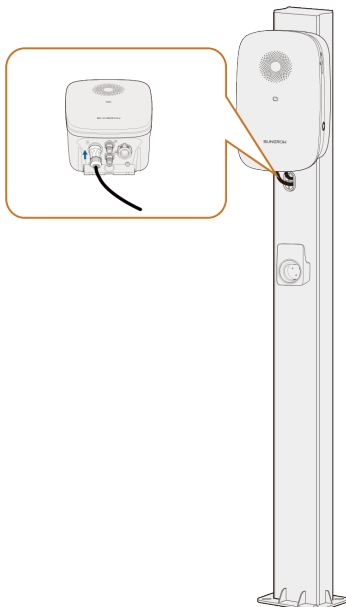
**Step 7** SIM card installation. For details, you can see [2.5 Wall-Mounting](#) step4

--End

## 3 Inspection before Commissioning

**Table 3-1** Requirements before commissioning

Item	Description
Location	The charger is correctly mounted at a place that is convenient for operation and maintenance.
Charger	The charger is firmly and securely installed.
Cable	Cables are correctly and firmly connected, and are adequately protected from damage.
Current leakage protection	The AC input's current leakage protection switch is reasonable.
Clearance	The charger has sufficient cooling space and there is no other stuff or components are left on the top of the charger.

**Step 1** Ensure that all requirements are met before commissioning.

**Step 2** Turn on the current leakage protection switch of the AC input.

**Step 3** Power on the charger.

The blue LED is solid on which indicates the charger is in standby mode.

--End

## 4 iEnergyCharge App

iEnergyCharge App is a tool that allows users to operate and manage their EV chargers. Users can complete account settings and charger configuration, manage charge cards, operate the charger, and reach customer service on the App.



- iEnergyCharge needed for commissioning only if the charger is used standalone, otherwise need to use iSolarCloud.
- In Australia, only the EMS model is supported.
- Depending on the version of iEnergyCharge you are using, the user interface might be slightly different.

### 4.1 Install iEnergyCharge App

#### Requirements

- Mobile OS: Android 6.0 or later, iOS 11.0 or later;
- The phone can connect to WLAN or 2G/3G/4G/5G network;
- The phone has sufficient storage space to install the App;
- The phone has sufficient battery power.

#### Steps

**Step 1** Search for **iEnergyCharge** in Google Play Store or App Store (iOS), or scan the QR code below with a mobile phone, and download the App following the onscreen instructions.



iEnergyCharge

**Step 2** Tap the downloaded installation package and follow the onscreen instructions to complete the installation.

--End

## 4.2 Create an Account

Two types of account are available, Owner and Retailer/Installer.



- Retailer/Installer: Users who provides services for owners. Installer users can use the iEnergyCharge App for guided commissioning and site setup, global monitoring of the operation of charging pools and equipment, and can perform operational and maintenance repairs via the App when equipment fails. Retailer/Installer accounts do not support starting or stopping charging.
- Owner: Users who will own or already own charging pools. Owner users can use the iEnergyCharge App for charging, card management, and configuring chargers.
- After logging into the App, the content displayed varies depending on the user role and device type.

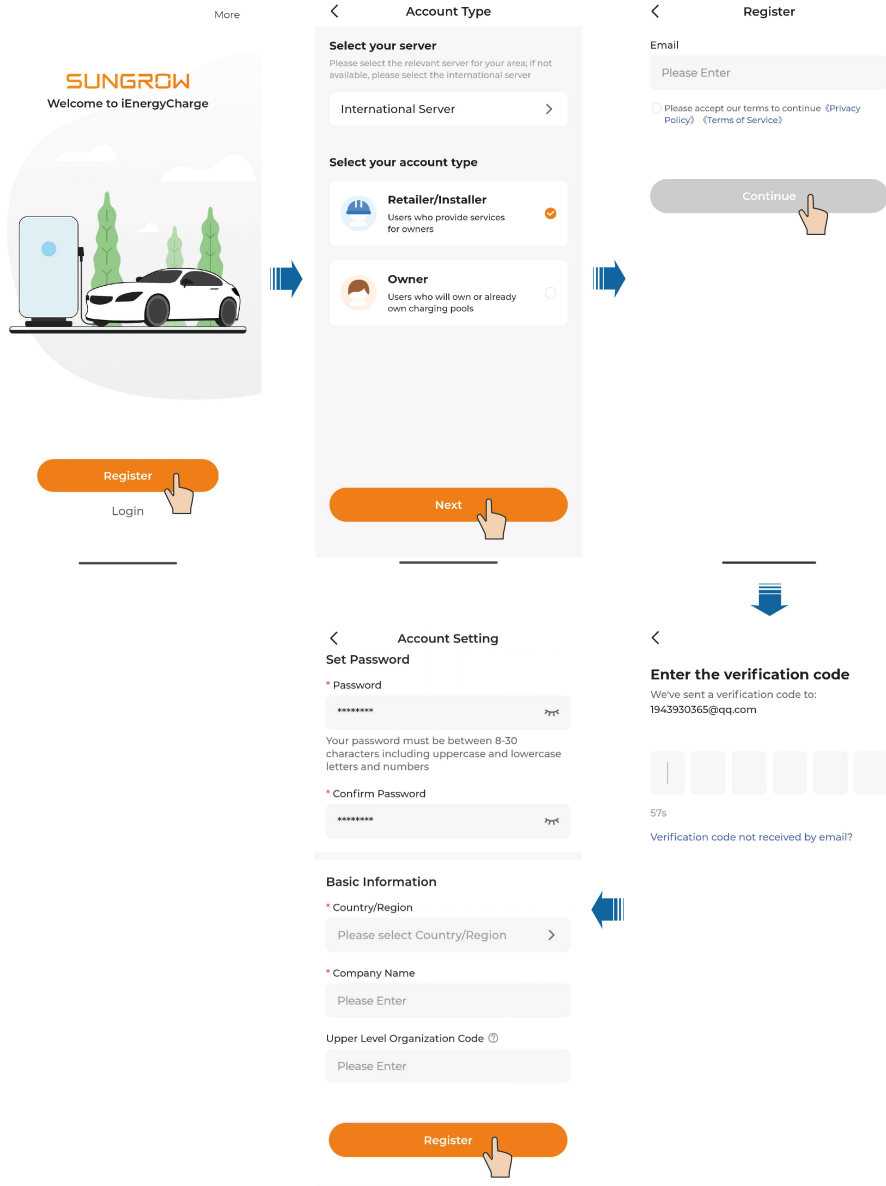

**Step 1** Tap **Register**.

**Step 2** Select a **Server**, then choose to create an **Retailer/Installer** or **Owner** account.

**Step 3** Enter an email address, agree to the privacy policy and terms of service, and tap **Continue**.

**Step 4** Enter the verification code you have received through email. If you do not receive a code by e-mail, please check your spam folder or ask customer service or the installer for the e-mail address that can be added to the safe senders.



- Users in mainland China may choose **Chinese Server**. Users in Europe may choose **European Server** and those in Australia may choose **Australian Server**. Users in other countries/regions may choose **International Server**.
- You can reach your upper-level retailer/installer for the "Code of Upper Level Installer/Retailer". Entering this code indicates that your organization is subordinate to an upper-level retailer/installer. If there is no upper-level retailer/installer organization, it is not necessary to fill in.

**Step 5** Enter a password, which should be 8–32 characters long and contain uppercase letters, lowercase letters, and numbers. Then, select the country/region, and tap **Register**. An account is now created.

--End

## 4.3 Log in to an Account

### Requirements

- You have installed the iEnergyCharge App;
- You have created an iEnergyCharge account, or obtained an account and password from the retailer/installer or SUNGROW.

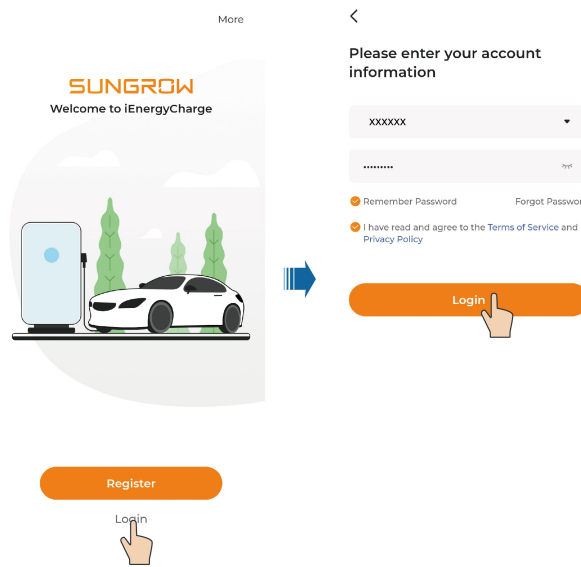

**Step 1** Open the iEnergyCharge App, and tap **Login**.

**Step 2** Enter your account name and password on the login screen, and tap **Login**. You will then go to the **Home** screen of the App.

--End

## 4.4 Device Operation and Maintenance

For more detailed information regarding the use of iEnergyCharge App, see [iEnergyCharge User Manual](#). You can also open the App and choose **Account > Support > User Manual** to view the manual.

Alternatively, you can scan the QR code below to view the manual.



## 4.5 Common operations for CPO

Requirements

- The operations of creating the charging pool, adding devices have been completed.

### Modify the ChargerId

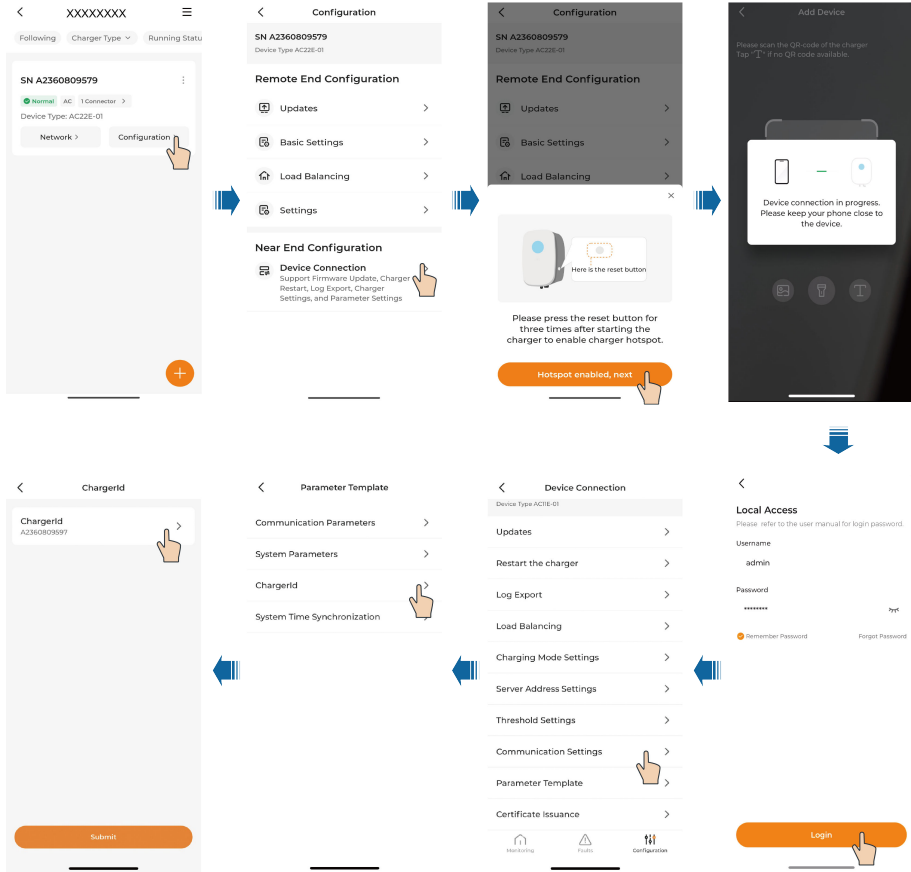

1. Go to “Configuration” and tap **Device Connection** to connect to the charger's WLAN.
2. After connecting, enter the account name and password to access local device settings screen.
3. Tap **Configuration > Communication Settings > ChargerId** to edit the **ChargerId**.
4. Tap **Submit** to save changes.

## Server Address Settings

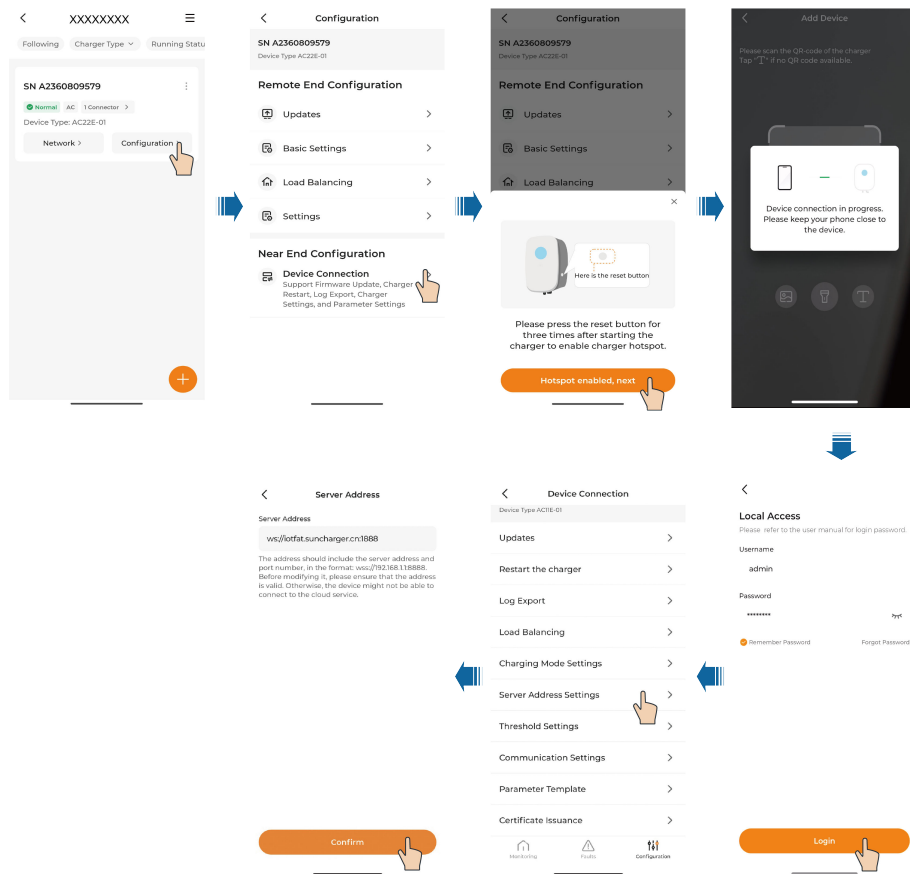

1. Go to “Configuration” and tap **Device Connection** to connect to the charger’s WLAN.
2. After connecting, enter the account name and password to access local device settings screen.
3. Tap **Configuration > Server Address Settings**. You can modify the **Server Address**.
4. Tap **Confirm**.

### Plug & Play Setup for Third-Party Platforms

To enable Plug & Play on a third-party platform selected by the user, configure the following parameters:

- **Activate Plug & Play:** Set key value “**FreeVendModeEn**” = “**True**” to change to Plug & Play during OCPP connection.
- **Set idTag for Plug & Play:** Set key value “**FreeVendModeldTag**” = “the charger’s Charger Code” to set the idTag for Plug & Play during OCPP connection.

### RFID Card Charging Setup for Third-Party Platforms



The third-party platform must support charging via RFID cards.

RFID cards successfully used on the charger while it was online will remain valid for offline charging.

The precondition is that the RFID card used at this charger must be among the most recent 20 cards, to prevent it from being overwritten.

And it is necessary to set both **“Local Authorize Offline”** and **“Authorization Cache Enabled”** to **“true”**.

## 5 Commissioning via iSolarCloud



- If the charger works under EMS mode, proceed with commissioning on the iSolarCloud App.
- When the charger works under EMS mode, if iHomeManager is not used, make sure it is connected to the inverter via the RS485 cable. For details on the RS485 cable connection, see [2.4.4 RS485 Communication Connection](#). If iHomeManager is used, a WLAN or LAN connection is required.

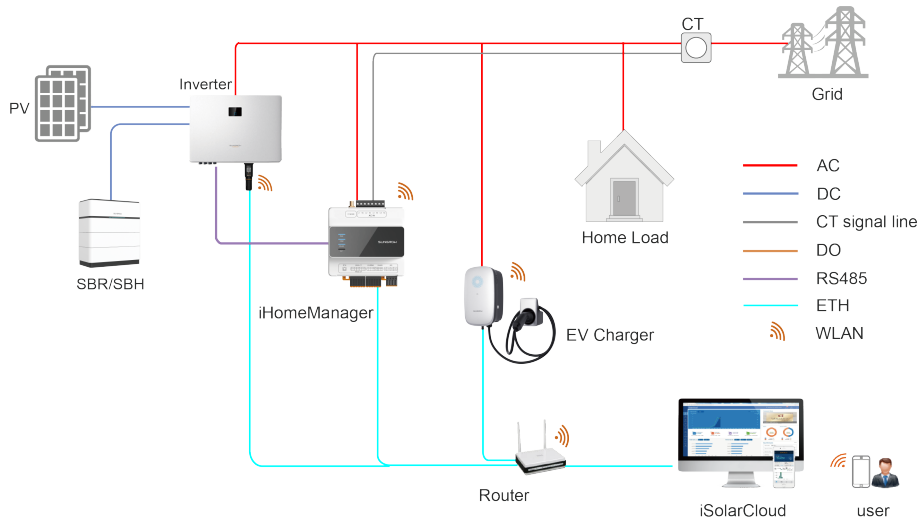

**Figure 5-1** System topology diagram of the solar-storage-charging solution with iHomeManager

### Download the iSolarCloud App

#### Option 1

Search for “iSolarCloud” in an application store, and download and install the App on your device.

- Google Play (Android)
- App Store (iOS)

#### Option 2

Scan the following QR code to download and install the App according to the prompt information.



### Commissioning on the iSolarCloud App

For detailed instructions for commissioning, please refer to the user manual of the inverter and iHomeManager:



[3-Phase Hybrid Inverter User Manual](#)



[iHomeManager User Manual](#)

## 6 Troubleshooting

**Table 6-1** Fault Resolution

Problem	Possible Cause	Solution
Overvoltage	<ol style="list-style-type: none"> <li>1. The grid voltage at the input end of the charger exceeds 276 V.</li> <li>2. The grid voltage is still above 264 V after overvoltage.</li> </ol>	<p>Usually, the charger will be reconnected to the grid once the grid returns to normal. If the problem occurs repeatedly:</p> <ol style="list-style-type: none"> <li>1. Measure the actual grid voltage, and contact local power company for solutions if the grid voltage is above 264 V.</li> <li>2. Contact Sungrow Customer Service if the problem persists.</li> </ol>
Undervoltage	<ol style="list-style-type: none"> <li>1. The grid voltage at the input end of the charger is below 184 V.</li> <li>2. The grid voltage is still below 195 V after undervoltage.</li> </ol>	<p>Usually, the charger will be reconnected to the grid once the grid returns to normal. If the problem occurs repeatedly:</p> <ol style="list-style-type: none"> <li>1. Measure the actual grid voltage, and contact the local power company for solutions if the grid voltage is below 195 V.</li> <li>2. Check if the AC cables are firmly connected.</li> <li>3. Contact Sungrow Customer Service if the problem persists.</li> </ol>
Overfrequency	<ol style="list-style-type: none"> <li>1. The mains AC frequency exceeds 63 Hz.</li> <li>2. The grid frequency is still above 61 Hz after overfrequency.</li> </ol>	<p>Usually, the charger will be reconnected to the grid once the grid returns to normal. If the problem occurs repeatedly:</p> <ol style="list-style-type: none"> <li>1. Measure the actual grid frequency, and contact the local power company</li> </ol>

Problem	Possible Cause	Solution
		<p>for solutions if the grid frequency is above 61 Hz.</p> <ol style="list-style-type: none"> <li>2. Contact Sungrow Customer Service if the problem persists.</li> </ol>
Underfrequency	<ol style="list-style-type: none"> <li>1. The mains AC frequency is below 47 Hz.</li> <li>2. The grid frequency is still below 49 Hz after underfrequency.</li> </ol>	<p>Usually, the charger will be reconnected to the grid once the grid returns to normal. If the problem occurs repeatedly:</p> <ol style="list-style-type: none"> <li>1. Measure the actual grid frequency, and contact the local power company for solutions if the grid frequency is below 49 Hz.</li> <li>2. Contact Sungrow Customer Service if the problem persists.</li> </ol>
EV	<p>Leakage current</p> <p>The DC leakage current is above 6 mA</p>	<ol style="list-style-type: none"> <li>1. Stop charging and pull out the charging connector. When the charger returns to normal, try charge again. If the problem occurs repeatedly, contact the EV manufacturer's customer service.</li> <li>2. Stop charging and pull out the charging connector. Contact Sungrow Customer Service if the problem persists.</li> </ol>
	<p>Overcurrent</p> <p>Output current is above 35 A</p>	
Charger	<p>Stuck relay</p> <p>The relay is stuck and cannot be disconnected.</p>	<p>Restart the charger and try again after 1 minute. If the problem occurs repeatedly, contact Sungrow Customer Service.</p>
	<p>Leakage current detection circuit failure</p> <ol style="list-style-type: none"> <li>1. The CT terminal has bad connection or the CT is malfunctioning.</li> <li>2. The RCD circuit is abnormal.</li> </ol>	

Problem	Possible Cause	Solution
Relay overtemperature	The temperature of the main relay is too high. It might be a hardware problem.	
CP failure	Abnormal CP loop circuit on the main board	
Wiring	Input terminal overtemperature 1. The input terminal is loosely connected which causes bad connection. 2. The cable's current-carrying capacity does not meet the requirements.	1. Ensure that the AC cable is tightly connected, that the cable used meets requirements, and L and N wires are correctly connected. 2. Contact Sungrow Customer Service if the problem persists.
	Reverse polarity	L and N wires are connected reversely.



If the above faults cannot be removed, please contact Sungrow.

If you encounter configuration issues between AC22E-01 charger and iHomeManager, please refer to [The issue that the stock AC22E-01 firmware version is too old](#)

# 7 Routine Inspection

## 7.1 Inspection Instructions

It is suggested to perform regular inspections on the device, so as to extend its service life. The inspection interval should be determined with on-site conditions taken into consideration. In case the device works in extreme weather conditions, be sure to shorten the inspection interval and increase inspection frequency.

- In case of a fault with the device, contact your local service provider or manufacturer immediately. Do not open the device without permission.
- If some devices need to be replaced during the inspection, please contact SUNGROW.
- Losses caused by failing to perform inspections in compliance with the instructions specified in this manual will not be covered by the warranty.
- Do not perform inspections on the device on rainy, humid, or windy days. SUNGROW shall not be held liable for any possible outcome resulted from inspections in such weather conditions.
- To reduce the risk of electric shocks, do not perform inspections that are not specified in this manual. If needed, please contact SUNGROW for inspection and repair services. Otherwise, damages caused therefrom will not be covered by the warranty.

## 7.2 Routine Inspection

It is recommended to perform routine inspections on the device once every 6 months. However, the actual inspection interval is subject to the operating environment.

Inspection Item	Inspection Method	Recommended Inspection Interval
Device exterior	<ul style="list-style-type: none"><li>• Check if there is any deformation with the enclosure of the device.</li><li>• Check if there is paint peeling on the exterior of the device.</li><li>• Check if the nameplate and marks on the device are all legible.</li><li>• Check if there is anything abnormal with the exterior of peripheral components such as the charging connector holder and antenna.</li></ul>	Once every 6 months

Inspection Item	Inspection Method	Recommended Inspection Interval
Device structure	<ul style="list-style-type: none"> <li>Check if the parts and components of the device are secure and reliable.</li> </ul>	Once every 6 months
Charging connector and charging cable	<ul style="list-style-type: none"> <li>Check the charging connector for any foreign matters. Ensure the pins inside the connector are clean without dirt. Clean off the foreign matters, if any, in time.</li> <li>Check the charging connector and charging cable for deficiency, crack, abrasion, damage, wire exposure, etc.</li> <li>If the charging connector freezes to the dispenser, it is recommended to carefully remove the ice with a cordless heat gun and a plastic scraper. During the heating process, please ensure that the temperature does not exceed 60°C and continuously move the heat gun back and forth to prevent damage to the charging connector or cable due to overheating.</li> </ul>	Once every 6 months
Electrical connections	<ul style="list-style-type: none"> <li>Check if the electrical line is burnt or has aged and if the fixing screws are loose.</li> <li>Check whether the grounding cable is properly connected to allow for reliable grounding.</li> <li>Check the cables for deficiency, crack, abrasion, damage, wire exposure, etc.</li> <li>Other inspection items can be arranged based on the actual situation on the site.</li> </ul>	Once every 6 months

# 8 Appendix

## 8.1 Technical Data

**Table 8-1** Technical Data

Specification	AC22E-01
<b>AC Input</b>	
Grid voltage	3 / N / PE, 230 V / 400 V
Nominal grid frequency	50 Hz / 60 Hz
Earthing system	TT / TN
Max. input current	32 A
Standby self-consumption	< 6.5 W
<b>AC Output</b>	
Max. charging power	22 kW or 11 kW @ 3-phase connection ( configurable ) 7.4 kW @ 1-phase connection
Max. charging voltage	230 V / 400 V
Max. charging current	32 A / 16 A ( configurable )
<b>Protection &amp; Function</b>	
Integrated fault current detection	DC 6 mA
Compatibility with external residual-current devices	External RCBO required, Type A or Type B according to IEC 62955
Overload protection	Yes
Over-temperature protection	Yes
Surge protection	Yes
Ground fault monitoring	Yes
ALM ( Adaptive load management )	Yes
Automatic phase switching	Yes

Specification	AC22E-01
<b>User interface</b>	
Display	LED indicator and App
Authentication	Plug & Play / RFID-card / iSolarCloud App / iEnergy Charge App
Firmware update	OTA
RFID system	Mifare ISO 14443 A
Energy metering	MID-certified meter ( optional )
Metering accuracy	Class B
Charging mode	OCPP / EMS by iEnergyCharge Eco charging / Fast Charging / Scheduled charging / Customized charging by iSolarCloud*
Communication interface	RS485 ( to Sungrow inverter / meter ) WLAN / Ethernet / 4G ( to cloud )
Communication protocol ( charger-to-CSMS )	OCPP 1.6 J
<b>Mechanical data</b>	
Dimensions ( W * H * D )	214 mm * 346 mm * 125 mm
Weight	< 6.65 kg
Installation method	Wall-mounting ( default ) Stand column ( optional )
AC cable specification	Cross-section up to 5 * 10 mm <sup>2</sup>
Charging cable length	5 m / 7 m ( optional )
Charging connector	Type 2
<b>Environmental data</b>	
Enclosure rating	IP65
Mechanical impact protection	IK10

Specification	AC22E-01
Operating ambient temperature range	-30 °C - 50 °C
Allowable relative humidity range	5 % - 95 % ( non-condensing )
Max. operating altitude	3000 m
Cooling method	Natural convection
<b>General data</b>	
Certifications	CE, CB, UKCA, RCM, ADQCC, MoIAT, PEA
Compliance	EN 300 328, EN 300 330, EN 301 489-1 / 3 / 17 / 52, EN 301 908-1 / 13, EN 50663, EN 50665, EN IEC 61851-1, EN IEC 61851-21-2, EN IEC 62311, EN 62479

\* In Australia, three charging modes are supported: Fast charging, ECO charging, and Economic charging.

## 8.2 Quality Assurance

When product faults occur during the warranty period, SUNGROW will provide free service or replace the product with a new one.

The software security update period for this product aligns with the warranty period. During the warranty, security patches or updates will be provided if any vulnerabilities or compatibility issues are identified.

### Evidence

During the warranty period, the customer shall provide the product purchase invoice and date. In addition, the trademark on the product shall be undamaged and legible. Otherwise, SUNGROW has the right to refuse to honor the quality guarantee.

### Conditions

- After replacement, unqualified products shall be processed by SUNGROW.
- The customer shall give SUNGROW a reasonable period to repair the faulty device.

### Exclusion of Liability

In the following circumstances, SUNGROW has the right to refuse to honor the quality guarantee:

- The free warranty period for the whole machine/components has expired.

- The device is damaged during transport.
- The device is incorrectly installed, refitted, or used.
- The device operates in harsh conditions beyond those described in this manual.
- The fault or damage is caused by installation, repairs, modification, or disassembly performed by a service provider or personnel not from SUNGROW.
- The fault or damage is caused by the use of non-standard or non-SUNGROW components or software.
- The installation and use range are beyond stipulations of relevant international standards.
- The damage is caused by unexpected natural factors.

For faulty products in any of above cases, if the customer requests maintenance, paid maintenance service may be provided based on the judgment of SUNGROW.



Product data such as product dimensions are subject to change without prior notice. The latest documentation from SUNGROW should take precedence in case of any deviation.

### 8.3 Contact Information

In case of questions about this product, please contact us. We need the following information to provide you the best assistance:

- Model of the device
- Serial number of the device
- Fault code/name
- Brief description of the problem

For detailed contact information, please visit: <https://en.SUNGROWpower.com/contactUS>

**SUNGROW**

Sungrow Power Supply Co., Ltd.

[www.sungrowpower.com](http://www.sungrowpower.com)