

# EnergyBridge

## Quick Installation Guide

### EB80S/EB80T



## Applicability

This manual is applicable to the Sungrow EnergyBridge models:

- EB80S
- EB80T

Keep the manual in a convenient place for future reference. The latest version can be found at [support.sungrowpower.com](http://support.sungrowpower.com).

## Target Group

Only qualified personnel with the following skills are authorized to perform the work described in this document:

- Trained in the installation and commissioning of the electrical systems.
- Capable of handling dangerous and emergency situations during installation and commissioning.
- Familiar with applicable national and regional standards and specifications.
- Knowledgeable about and compliant with this manual and other related documents.

## Intended Use

- EB80S is primarily used for the on-grid/off-grid switching in whole-home backup and retrofit scenario featuring a single SH3.0-10RS inverter.
- EB80T is primarily used for the on-grid/off-grid switching in whole-home backup and retrofit scenario featuring a single SH5-25T inverter.
- Any use other than those described in this document is not considered appropriate and is prohibited. Do not modify the product in any way.
- Improper use may result in damage to or destruction of the EnergyBridge. The EnergyBridge must not be operated beyond the limits specified in the technical data.

### DANGER

Lethal voltages and danger to life due to electric shock!

- Only use the EnergyBridge in dry environments and keep it away from liquids.
- Install the EnergyBridge inside a switch cabinet only and ensure that the connection areas for the line and the neutral conductors are protected by an insulating cover or have adequate contact protection.
- Disconnect the EnergyBridge from all voltage sources before cleaning. Clean only with a dry cloth.

### WARNING

Fire hazard!

- If a fuse is missing or of the wrong type, a fault may cause a fire, resulting in death or serious injury.

## Label



RCM mark of conformity.



CE mark of conformity.  
EU/EEA Importer.

## Delivery Contents

Name	Quantity	Name	Quantity
EB (EnergyBridge)*	1	LED & Button status information label	1
Inverter COM adapter cable	1	Warning label	1
EB COM adapter cable	1	Documents	1

\*The appearance of the actual product may vary, but the functions are the same. In the following text, EB stands for EnergyBridge.

## ⚠ NOTICE

- Contact Sungrow or the distributor if any components are damaged or missing.
- Please make sure to affix the **LED indicator and button description**, and **warning label** from the scope of delivery to a prominent location inside the power distribution box.

## Terminals

Taking EB80T as an example.

Front:

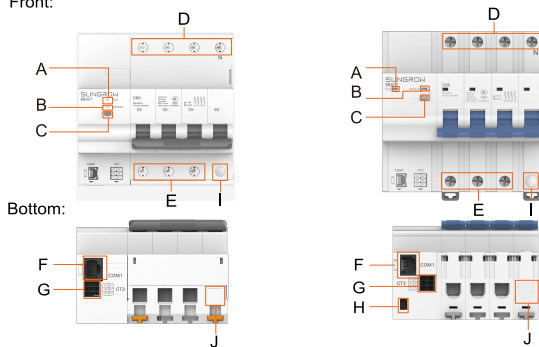

Designation	Description
A	RUN indicator <sup>[1]</sup>
B	MANUAL indicator <sup>[2]</sup>
C	MANUAL button <sup>[2]</sup>
D	EB80S: Grid L, N* EB80T: Grid L1, L2, L3, N*
E	EB80S: Inverter L, Load L EB80T: Inverter L1, L2, L3, Load L1, L2, L3
F	RS485 <sup>[3]</sup>
G	CT**
H/I***/J***	Reserved

\* The grid-side neutral conductor is connected to the N-Bar. For AU/NZ, the load-side neutral conductor may be left unconnected.

\*\* 100 A / 333 mV voltage-type CT; used only for third-party inverters in a retrofit scenario.

\*\*\*For AU/NZ, I/J requires no special handling. For other countries, use a flat-head screwdriver to pry open I and J.

## LED & Button Status Information

[1] RUN LED

Indicator	Status	Description
Blue	Steady on	No communication with inverter.
	Blink	Normal communication with inverter.
Red	Steady on	There is a fault in the EB.
	Blink	There is an alarm in the EB.

## [2] MANUAL LED & Button

Indicator	Status	Description	Button & EB Operation
Blue	Slow blink (0.5 s)	The EB works with inverter control.	<ul style="list-style-type: none"> <li>• If the inverter is normal or the EB is closed, do not operate the MANUAL button.</li> <li>• If the inverter is abnormal and the EB is open, press and hold the MANUAL button for 2s until the LED is steady on, then close the EB manually.</li> </ul>
	Steady on	The EB works in manual mode.	<ul style="list-style-type: none"> <li>• When the EB is open, close the EB manually within 30s.</li> <li>• When the EB is closed, press and hold the MANUAL button for 2s to restore inverter control. Then the LED will slow blink.</li> </ul>
	Fast blink (0.05 s)	The EB trips due to overcurrent, manual open or short-circuit.	<ul style="list-style-type: none"> <li>• Check household load for short-circuit.</li> <li>• Press and hold the MANUAL button for 2s until the LED is steady on, then close the EB manually.</li> </ul>
	Off	The EB trips due to no grid power.	The system works in off-grid mode. Please do not operate the MANUAL button or close the EB.

## [3] RS485



TIA/EIA 568A

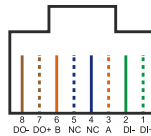

TIA/EIA 568B

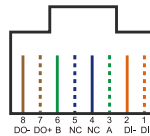

No.	Label	568A	568B	Description
1	DI+	White-Green	White-Orange	Connects to the inverter's COM: i.e. COM (SH3.0-6.0RS) or COM2 (SH8.0-10RS, SH5-25T)
2	DI-	Green	Orange	Connects to the inverter's DO*, i.e. NO (SH3.0-6.0RS) or NO2 (SH8.0-10RS, SH5-25T)
3	A	White-Orange	White-Green	Connects to A2 of the inverter's Meter
4	NC	Blue	Blue	Reserved
5	NC	White-Blue	White-Blue	Reserved
6	B	Orange	Green	Connects to B2 of the inverter's Meter
7	DO+	White-Brown	White-Brown	Connects to the inverter's RSD-1**
8	DO-	Brown	Brown	Connects to the inverter's RSD-2**

\* The DO interface of the inverter supports multiplexing. When the DO interface is connected to the EB, its original function is disabled. The interface will be multiplexed to serve as the EB's circuit breaker.

\*\* The RSD interface of the inverter supports multiplexing. When the RSD interface is connected to the EB, its original function is disabled. The interface will be multiplexed to serve as the EB's status feedback.

Note1: Please select either TIA/EIA 568A or TIA/EIA 568B, and ensure that both ends of the Ethernet cable use the same wiring standard.

Note2: The inverter communication port requires a 120Ω resistor connected in parallel.

## Installation and Cable Connection

**Step 1** Install the inverter.

**Step 2** After opening the main circuit breaker to ensure that the grid side is disconnected and de-energized, install the EB on the rail.

**Step 3** EB wiring. Please use crimp terminals to connect the inverter to the grid-side and the load-side L/N cables.

EB80S wiring:

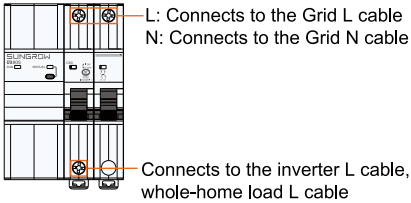

Connects to the inverter  
communication interface

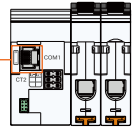

EB80T wiring:

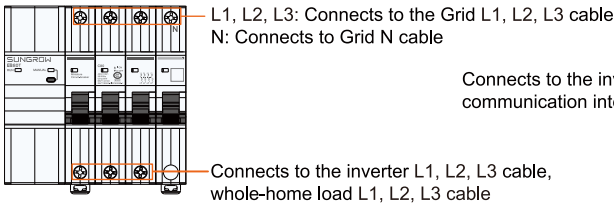

Connects to the inverter  
communication interface

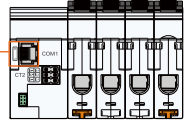

**Step 4** Complete the system communication wiring as shown in the figure below.

Note: Take TIA/EIA 568B as an example of EB's Ethernet cable standard.

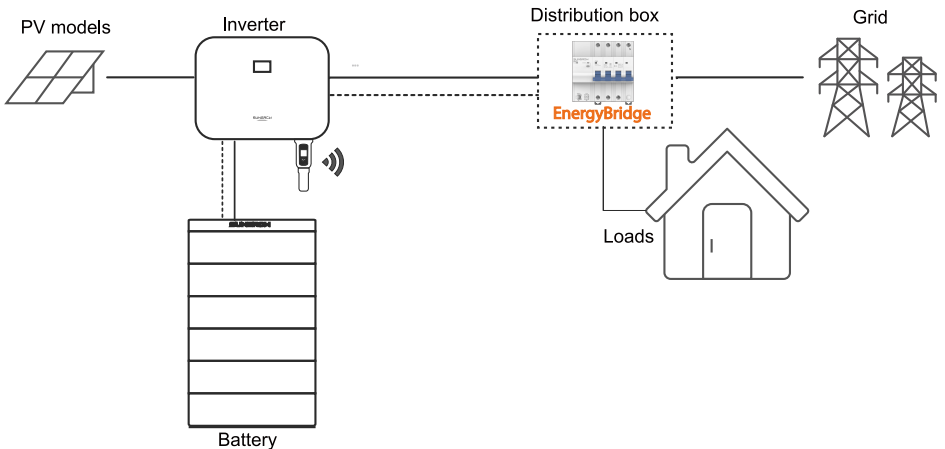

**EB80S for AU/NZ** (The following examples illustrate the specific wiring for the EB80S using the SH8.0/10RS and SBH200).

**Scenario 1: Whole Home Backup (EB80S)**

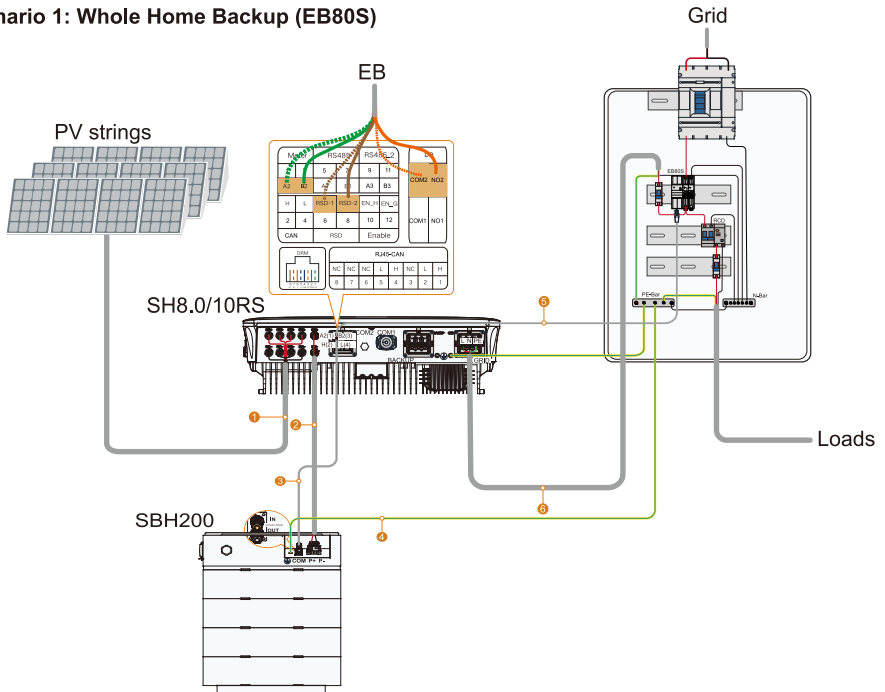

The communication wiring diagram for SH3.0/3,6/4,0/5,0/6,0RS is shown in the figure below.

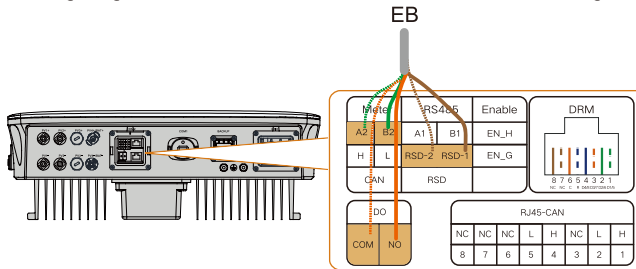

**Cable Requirements:**

No.	Cable	Type	Cross-section	Cable Diameter
1	PV Cable	Outdoor multi-core copper cable rated for 600 V, 16 A	4 mm <sup>2</sup> –6 mm <sup>2</sup> (12 AWG–10 AWG)	6.4 mm–9.0 mm
2	Battery Power Cable	Outdoor multi-core copper cable rated for 1000 V	SBR: 6 mm <sup>2</sup> (10 AWG) SBH: 10 mm <sup>2</sup> (7 AWG)	6.4 mm–8.5 mm
3	Battery Communication Cable	CAT 5E shielded ethernet cable	/	/
4	Additional Grounding Cable	Outdoor single-core copper cable	The same as that of the PE wire in the AC cable.	
5	Communication Cable	Outdoor shielded ethernet cable, CAT 5E / CAT 6	0.08 mm <sup>2</sup> –0.2 mm <sup>2</sup>	4.8 mm–6.0 mm
6	AC Cable	Outdoor multi-core copper cable	14 mm <sup>2</sup> –16 mm <sup>2</sup> (6 AWG–5 AWG)	21 mm–25.8 mm

## Scenario 2: Retrofitting the existing PV system (EB80S)

Note 1: The power of the PV inverter must not exceed the power of the hybrid inverter.

Note 2: The PV inverter must support frequency shift power control.

Note 3: Single-phase hybrid inverters do not support three-phase PV inverters.

Note 4: Third-party PV inverters require an external CT connection to CT2 (IA/IA\*) terminal on the EB.

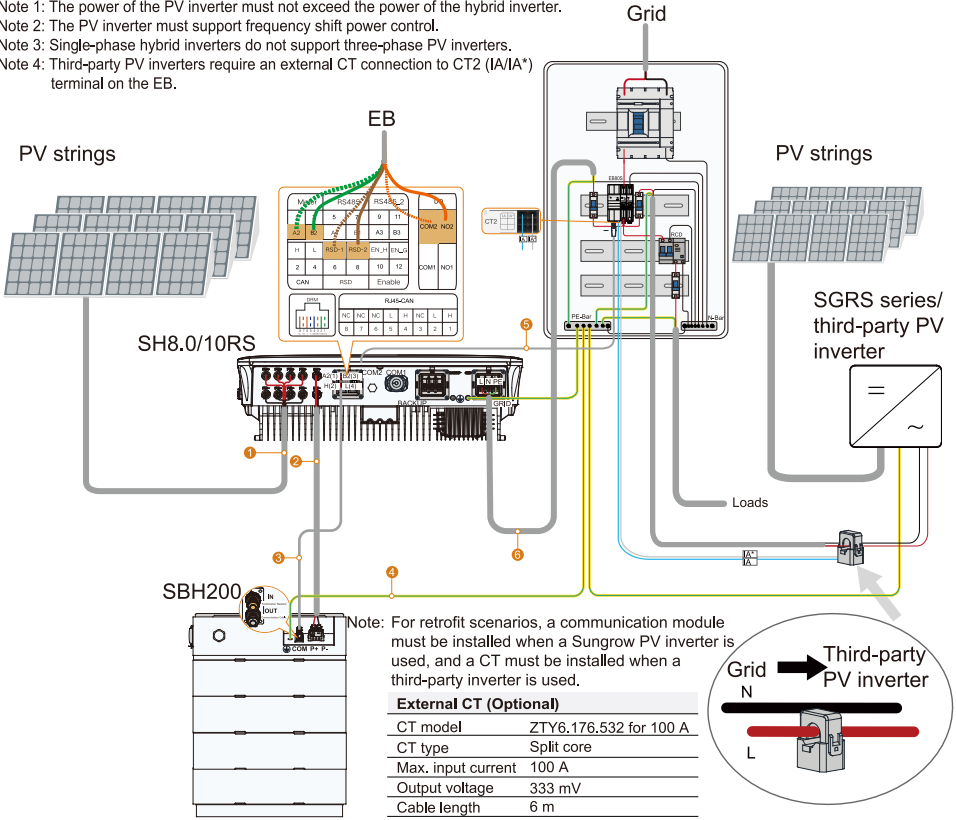

The communication wiring diagram for SH3.0/3.6/4.0/5.0/6.0RS is shown in the figure below.

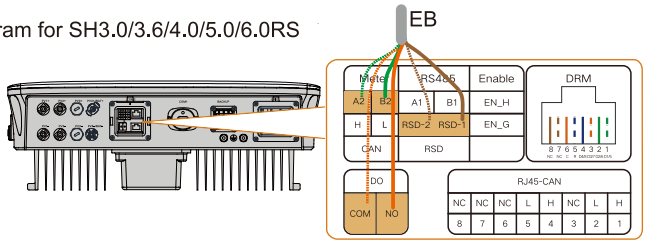

### Cable Requirements:

No.	Cable	Type	Cross-section	Cable Diameter
①	PV Cable	Outdoor multi-core copper cable rated for 600 V, 16 A	4 mm <sup>2</sup> –6 mm <sup>2</sup> (12 AWG–10 AWG)	6.4 mm–9.0 mm
②	Battery Power Cable	Outdoor multi-core copper cable rated for 1000 V	SBR: 6 mm <sup>2</sup> (10 AWG) SBH: 10 mm <sup>2</sup> (7 AWG)	6.4 mm–8.5 mm
③	Battery Communication Cable	CAT 5E shielded ethernet cable	/	/
④	Additional Grounding Cable	Outdoor single-core copper cable	The same as that of the PE wire in the AC cable.	
⑤	Communication Cable	Outdoor shielded ethernet cable, CAT 5E / CAT 6	0.08 mm <sup>2</sup> –0.2 mm <sup>2</sup>	4.8 mm–6.0 mm
⑥	AC Cable	Outdoor multi-core copper cable	14 mm <sup>2</sup> –16 mm <sup>2</sup> (6 AWG–5 AWG)	21 mm–25.8 mm

**EB80T for AU/NZ** (The following examples illustrate the specific wiring for the EB80T using the SH25T and SBH300).

**Scenario 1: Whole Home Backup (EB80T)**

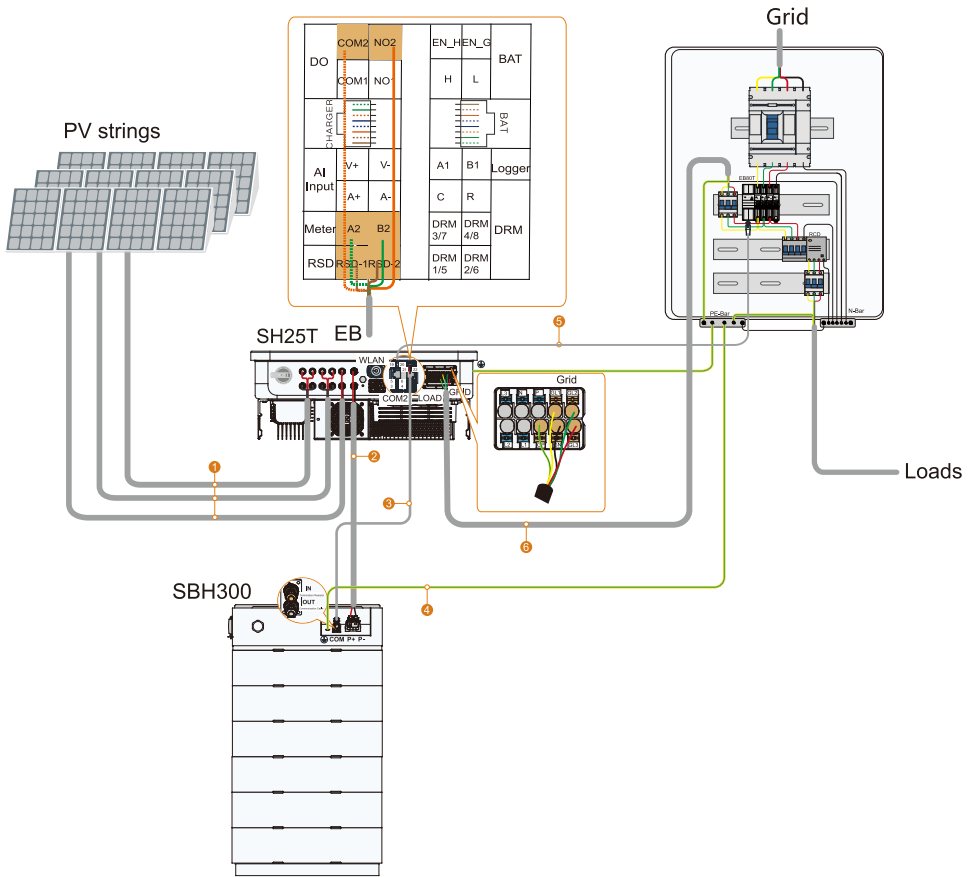

**Cable Requirements:**

No.	Cable	Type	Cross-section	Cable Diameter
1	PV Cable	Outdoor copper cable rated for 1000 V	4 mm <sup>2</sup> –6 mm <sup>2</sup> (12 AWG–10 AWG)	6.4 mm–8.0 mm
2	Battery Power Cable	Outdoor multi-core copper cable rated for 1000 V	SBR: 6 mm <sup>2</sup> (10 AWG) SBH: 10 mm <sup>2</sup> (7 AWG)	6.4 mm–8.5 mm
3	Battery Communication Cable	CAT 5E shielded ethernet cable	/	/
4	Additional Grounding Cable	Outdoor single-core copper cable	The same as that of the PE wire in the AC cable.	
5	Communication Cable	Outdoor shielded ethernet cable, CAT 5E / CAT 6	8 * 0.2 mm <sup>2</sup> (24 AWG)	5 mm–6.4 mm
6	AC Cable	Outdoor multi-core copper cable	SH5-12T: 6 mm <sup>2</sup> –10 mm <sup>2</sup> (10 AWG–7 AWG) SH15-25T: 10 mm <sup>2</sup> –16 mm <sup>2</sup> (7 AWG–5 AWG)	SH5-12T: 14.4 mm–23 mm SH15-25T: 21 mm–27.5 mm

## Scenario 2: Retrofitting the existing PV system (EB80T)

Note 1: The power of the PV inverter must not exceed the power of the hybrid inverter.

Note 2: The PV inverter must support frequency shift power control.

Note 3: Third-party PV inverters require three external CTs connection to CT2 (IA/IA\*, IB/IB\*, IC/IC\*) terminal on the EB.

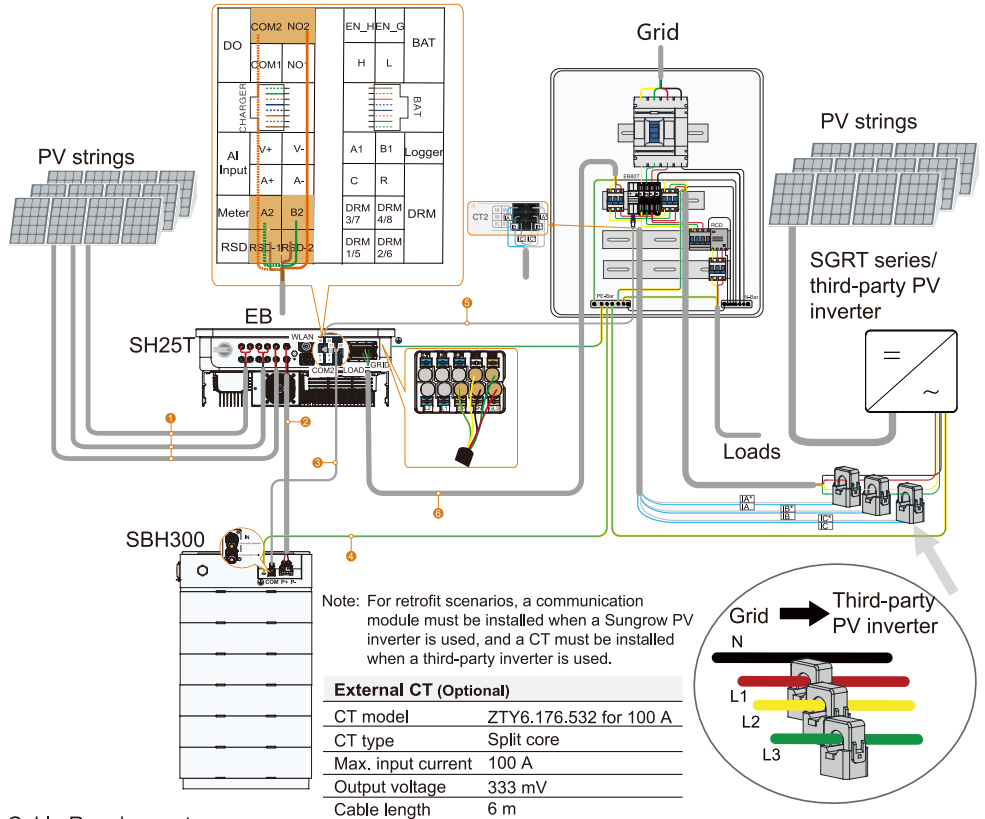

### Cable Requirements:

No.	Cable	Type	Cross-section	Cable Diameter
1	PV Cable	Outdoor copper cable rated for 1000 V	4 mm <sup>2</sup> –6 mm <sup>2</sup> (12 AWG–10 AWG)	6.4 mm–8.0 mm
2	Battery Power Cable	Outdoor multi-core copper cable rated for 1000 V	SBR: 6 mm <sup>2</sup> (10 AWG) SBH: 10 mm <sup>2</sup> (7 AWG)	6.4 mm–8.5 mm
3	Battery Communication Cable	CAT 5E shielded ethernet cable	/	/
4	Additional Grounding Cable	Outdoor single-core copper cable	The same as that of the PE wire in the AC cable	
5	Communication Cable	Outdoor shielded ethernet cable, CAT 5E / CAT 6	8 * 0.2 mm <sup>2</sup> (24 AWG)	5 mm–6.4 mm
6	AC Cable	Outdoor multi-core copper cable	SH5-12T: 6 mm <sup>2</sup> –10 mm <sup>2</sup> (10 AWG–7 AWG) SH15-25T: 10 mm <sup>2</sup> –16 mm <sup>2</sup> (7 AWG–5 AWG)	SH5-12T: 14.4 mm–23 mm SH15-25T: 21 mm–27.5 mm

**Step 5** Complete all wiring, close the main circuit breaker, and ensure power supply on the grid side.

**Step 6** Close the inverter's AC switch, the inverter's DC switch, and the battery switch, and wait for the system to start up and run.

—End

## FAQ

- Question 1: How do I test the on-grid/off-grid switching function after the initial installation is complete?
- Answer 1: Once installation is complete and the inverter is running normally on grid, test the system's on-grid/off-grid switching function by opening the main circuit breaker to simulate a power outage and subsequent restoration.
- Question 2: How to power loads when the inverter is faulty and under maintenance?
- Answer 2: During the troubleshooting phase, when the inverter is completely powered down or removed, and the grid is still energized, the EB will automatically close the circuit without manual intervention.
- Question 3: What is the status of the EB after an overcurrent or short-circuit fault occurs on site? How should I handle it?
- Answer 3: In the event of an overcurrent or short-circuit fault on site, the EB indicates that the circuit breaker is open, and the MANUAL indicator fast blinks. At this time, check the consumption of household loads to ensure there is no short-circuit. Then, press and hold the MANUAL button for 2s. The circuit breaker can be closed manually only after the MANUAL indicator is steady on.
- Question 4: Can I substitute a circuit breaker with an EB?
- Answer 4: The EB can only substitute a circuit breaker with the same rated current.
- Question 5: How many hybrid inverters does the system support? Does it support EV chargers?
- Answer 5: The system supports only one hybrid inverter and does not support the connection of EV chargers.
- Question 6: What is the system's load-carrying capacity during off-grid operation? What should I do if the inverter's output power fails to meet the power demand during off-grid operation?
- Answer 6: The system's off-grid load-carrying capacity is controlled by the inverter. For details, please refer to the corresponding inverter user manual. If the inverter's output power fails to meet the loads' power demand during off-grid operation, disconnect some loads or replace the inverter with a higher-power model.
- Question 7: Does the EB require manual opening and closing?
- Answer 7: Generally, the EB is controlled by the inverter and does not require manual opening or closing operations. Manual closing is allowed only when the grid is energized, but the inverter is faulty and under maintenance, and the EB is open, causing household loads to lose power. Complete the inverter maintenance. Manually close the breaker. Then manually press the MANUAL button again or use the iSolarCloud App to restore inverter control.
- Question 8: Can 1-phase hybrid inverter SH3.0-10RS be connected to a three-phase EB?
- Answer 8: Connection is allowed. It should be noted, however, that the SHRS must be connected to the L1 terminal on the output side of the three-phase EB. The L2 and L3 terminals may be connected to loads or 1-phase PV inverters. If a third-party inverter is used, a second current transformer (CT) is necessary for monitoring.

⚠ EB is strictly prohibited from being installed in environments with vibration or strong electromagnetic fields (including strong common-mode interference). A strong magnetic field environment refers to one where the magnetic field strength exceeds 30 A/m. The aforementioned environments may cause the product to malfunction.

⚠ Please disconnect the main circuit breaker and the AC-side miniature circuit breaker of the inverter, and ensure that the EB is de-energized. Wait 10 seconds before operating the EB's wiring, including the L/N, external CT, and communication cables.

Question 9: How to determine if the EB is faulty?

Answer 9: If grid power is present but the RUN indicator is red or off: The EB is faulty. Disconnect the AC circuit breaker on the inverter side, try manual closing via the MANUAL button, and contact the installer for replacement.  
If grid power is present and the RUN indicator is blue: Normal operation but communication with the inverter is abnormal. Disconnect the AC circuit breaker on the inverter side, try manual closing via the MANUAL button, and contact the installer to check/replace the communication cable.

### Technical Data

Parameter	EB80S	EB80T
<b>Specification</b>		
Rated current	80 A	
Rated voltage (AC)	230 V/240 V	400 V/415 V
Frequency	50 Hz/60 Hz	
Power grid type	L-N	L1/L2/L3-N
Circuit breaker poles	2P	4P
Backup switch time	≤ 10 ms	
Trip curve type	C	
Voltage operating range	0.75 Un~1.3 Un	
Maximum measured current	80 A	
Rated short-circuit capacity	6 kA	
Rated insulation voltage	500 V	
Rated impulse withstand voltage	4 kV	
Communication interface	RS485*1, DI*1, DO*1	
Interface form	RJ45	
Communication distance	≤ 100 m	
<b>General data</b>		
Dimensions (W x H x D)	72 mm x 105 mm x 79 mm	108 mm x 105 mm x 79 mm
Weight	480 g	780 g
Reference set temperature	30°C	
Operating ambient temperature range	-25°C to 60°C	
Humidity (non-condensing)	≤ 95%	
Max. operating altitude	2000 m	
Degree of protection	IP20	
Compliance	CE, RCM, IEC60898-1, IEC61326-1, IEC61000-6-2/3	
Accuracy class	I	
EMC	Class B	
Circuit breaker function	Yes	
On-grid/Off-grid switching function	Yes	
Whole home backup function	Yes	
Bypass function	Yes	
Manual/Automatic reclosing	Yes	
Built-in CT/External CT/Energy metering	Yes	
Mounting method	35 mm Din-rail mounting	
Compatible models	SH3.0-10RS, SH5-25T	
Country of manufacture	China	

### Temperature derating factor

Temperature (°C)	-25	-20	-15	-10	-5	0	5	10	15	20	25	30	35	40	45	50	55	60
Rated current (A)	97	95	94	92	91	89	88	86	84	83	81	80	78	76	74	72	70	68



More information in the QR code or  
at <http://support.sungrowpower.com/>

**SUNGROW**

Sungrow Power Supply Co., Ltd.

[www.sungrowpower.com](http://www.sungrowpower.com)



M 0 H 0 1 4 7 3 0 0 - 6

CIEN M0H01473