

# User Manual

## Hybrid Inverter

SH110CX/SH125CX



---

# All Rights Reserved

## All Rights Reserved

No part of this document can be reproduced in any form or by any means without the prior written permission of Sungrow Power Supply Co., Ltd (hereinafter "SUNGROW").

## Trademarks

**SUNGROW** and other SUNGROW trademarks used in this manual are owned by SUNGROW.

## Software Licenses

- It is prohibited to use data contained in firmware or software developed by SUNGROW, in part or in full, for commercial purposes by any means.
- It is prohibited to perform reverse engineering, cracking, or any other operations that compromise the original program design of the software developed by SUNGROW.

# About This Manual

This manual gives an introduction to the inverter product as well as instructions on the installation, operation, and maintenance of the inverter, yet not all-encompassing regarding the information about the PV system. You may visit [www.sungrowpower.com](http://www.sungrowpower.com) or the website of the device manufacturer for more information.

## Scope of Application

This manual applies to the following devices:

- SH110CX
- SH125CX

It will be referred to as "inverter" hereinafter unless otherwise specified.

## Target Group

This manual is intended for professional technicians who are responsible for installation, operation, and maintenance of inverters, and users who need to check inverter parameters.

Installation can only be done by qualified technical persons, Qualified personnel must:

- Have certain electrical wiring, electronic, and mechanical expertise, and be familiar with electrical and mechanical schematics;
- Have received professional training in the installation and commissioning of electrical equipment;
- Be able to respond quickly to dangers or emergencies that may occur during the process of installation and commissioning;
- Be familiar with applicable local standards and relevant safety regulations on electrical systems;
- Read through this manual carefully and have a good understanding of the relevant safety instructions.

## How to Use This Manual

Read through this manual carefully before using the product, and keep it properly in an easy-to-reach place.

The manual may be updated and revised from time to time, however, there still might be slight deviations from the real product or errors. In such cases, the actual product you have purchased should take precedence. You can find the latest version of the manual at [support.sungrowpower.com](http://support.sungrowpower.com) or reach your sales for it.

## Security Disclaimer

To learn more about the product cybersecurity vulnerability disclosure and handling process, visit <https://en.sungrowpower.com/security-vulnerability-management>.

For more cybersecurity details, please refer to the user manual of the corresponding communication module/data logger provided with the product.

### Symbol Explanations

To ensure the safety of life and property for users when using the product and to improve the efficiency of product use, the manual provides relevant information, which are highlighted by the following symbols.

Symbols used in this manual are listed below. Please review carefully for better use of this manual.

#### **DANGER**

Indicates high-risk potential hazards that, if not avoided, may lead to death or serious injury.

#### **WARNING**

Indicates moderate-risk potential hazards that, if not avoided, may lead to death or serious injury.

#### **CAUTION**

Indicates low-risk potential hazards that, if not avoided, may lead to minor or moderate injury.

#### **NOTICE**

Indicates potential risks that, if not avoided, may lead to device malfunctions or financial losses.



Indicates additional information, emphasized contents, or tips that may be helpful, e.g. to help you solve problems or save time.

# Contents

---

All Rights Reserved.....	I
About This Manual.....	II
<b>1 Safety Instructions.....</b>	<b>1</b>
1.1 Unpacking and Inspection.....	2
1.2 Installation Safety.....	3
1.3 Electrical Connection Safety.....	3
1.4 Operation Safety.....	6
1.5 Maintenance Safety.....	6
1.6 Disposal Safety.....	7
<b>2 Product Description.....</b>	<b>8</b>
2.1 Product Overview.....	8
2.2 Symbols on the Product.....	9
2.3 LED Indicators.....	10
2.4 DC Switch.....	13
2.5 Circuit Diagram.....	13
<b>3 System Application Introduction.....</b>	<b>15</b>
3.1 System Application Overview.....	15
3.2 PV Energy Storage System (PV ESS).....	15
3.2.1 PV ESS Introduction.....	15
3.2.2 Backup Function Statement.....	16
3.2.3 Energy Management.....	16
3.3 System Application Scenarios.....	19
3.3.1 Pure Grid-connected System Scenario.....	19
3.3.1.1 System Overview.....	19
3.3.1.2 Single-inverter System.....	19
3.3.1.3 Multi-inverter System.....	22
3.3.2 On/off-grid System Scenario.....	23
3.3.2.1 System Overview.....	23
3.3.2.2 Single-inverter System.....	25
3.3.2.3 Multi-inverter System.....	34
3.3.3 Pure Off-grid System Scenario.....	45
3.3.3.1 System Overview.....	45
3.3.3.2 Single-inverter System.....	45
3.3.3.3 Multi-inverter System.....	47

3.3.4 Third-party Dispatching.....	48
<b>4 Function Description.....</b>	<b>49</b>
4.1 Safety Function.....	49
4.1.1 Protection.....	49
4.1.2 Grounding Fault Alarm.....	49
4.2 Energy Conversion and Management.....	49
4.2.1 Power Derating.....	49
4.2.2 Normal Operating Voltage Range.....	49
4.2.3 Normal Operating Frequency Range.....	50
4.2.4 Reactive Power Regulation.....	50
4.2.5 Load Control.....	50
4.2.6 Battery Management.....	50
4.2.7 Meter Management.....	50
4.3 Communication and Configuration.....	51
<b>5 Unpacking and Storage.....</b>	<b>52</b>
5.1 Unpacking and Inspection.....	52
5.2 Scope of Delivery.....	53
5.3 Inverter Storage.....	54
<b>6 Mechanical Mounting.....</b>	<b>55</b>
6.1 Installation Precautions.....	55
6.2 Installation Site Selection.....	55
6.2.1 Installation Environment Requirements.....	56
6.2.2 Installation Support Requirements.....	58
6.2.3 Installation Angle.....	59
6.2.4 Installation Space Requirements.....	60
6.3 Installation Tools.....	62
6.4 Move Inverter.....	64
6.5 Install Mounting Bracket.....	65
6.5.1 Mounted on PV Bracket.....	66
6.5.2 Mounted on Wall.....	68
6.5.3 Mounted on Pole.....	70
6.6 Mount the Inverter.....	72
<b>7 Electrical Connection.....</b>	<b>74</b>
7.1 Installation Precautions.....	74
7.2 Terminal Description.....	76
7.3 Electrical Connection Overview.....	77
7.4 Crimp OT/DT terminal.....	86
7.5 External Protective Grounding Connection.....	87
7.5.1 Requirements for External Protective Grounding.....	88

7.5.2 Wiring Steps.....	88
7.6 AC Cable Connection.....	88
7.6.1 AC side Requirements.....	89
7.6.2 OT/DT Terminal Requirements.....	90
7.6.3 AC Cable Connection.....	91
7.6.3.1 Wiring Steps (for 8-hole terminal block/ multi-core cable).....	91
7.6.3.2 Wiring Steps (for 16-hole terminal block/ single-core cable).....	97
7.7 DC Cable Connection.....	105
7.7.1 PV Input Configuration.....	107
7.7.2 Assemble DC Connector (MC4).....	109
7.7.3 Installing PV Connector.....	110
7.8 Battery Connection.....	111
7.8.1 Electrical Connection Requirements.....	111
7.8.2 Assemble Battery Connector.....	112
7.9 Communication Connection.....	114
7.9.1 Communication Terminal Cover.....	114
7.9.2 Communication Wiring Area.....	115
7.9.3 RS485 Communication Connection.....	116
7.9.3.1 Interface Description.....	117
7.9.3.2 RS485 Communication Wiring.....	117
7.9.3.3 Wiring Steps (Terminal Block).....	119
7.9.4 Dry Contact Function.....	122
7.9.4.1 Wiring Steps.....	124
7.9.5 DRM Connection.....	124
7.9.6 DSP Communication Connection.....	128
7.9.7 Battery Communication Connection.....	128
7.10 Install Protective Cover (Optional for SH110CX).....	130
<b>8 iSolarCloud App.....</b>	<b>134</b>
8.1 About iSolarCloud.....	134
8.2 Install iSolarCloud.....	135
8.3 User Roles.....	136
8.4 Device Commissioning.....	136
<b>9 Commissioning.....</b>	<b>137</b>
9.1 Inspection Before Commissioning.....	137
9.2 Commissioning Steps .....	137
<b>10 Inverter Decommissioning.....</b>	<b>139</b>
10.1 Shut Down the Inverter.....	139
10.2 Dismantle the Inverter.....	139
10.3 Dispose of Inverter.....	140

<b>11 Troubleshooting and Maintenance</b> .....	141
11.1 Troubleshooting.....	141
11.2 Maintenance.....	148
11.2.1 Maintenance Precautions.....	148
11.2.2 Routine Maintenance.....	149
11.2.3 Fan Maintenance.....	150
11.2.4 Clean Air Outlet.....	152
11.2.5 DC Switch Maintenance.....	152
<b>12 Appendix</b> .....	154
12.1 Technical Data.....	154
12.2 Wring Distance of DI Dry Contact.....	158
12.3 Quality Assurance.....	160
12.4 Contact Information.....	161

# 1 Safety Instructions

Follow strictly the relevant safety instructions during the process of product installation, commissioning, operation, and maintenance. Improper use or incorrect operation may result in:

- Injury to or death of the operator or other people.
- Damage to the product, or to the property that belongs to the operator or a third party.

Strictly follow the safety instructions stated in the manual to avoid the hazards mentioned above.

## **WARNING**

**Do not perform any operation on the product (including but not limited to, handling, installing, powering on, and maintaining the product, performing electrical connection, and working at heights) in harsh weather conditions, such as thunder and lightning, rain, snow, and Level 6 or stronger winds. SUNGROW shall not be held liable for any damage to the product due to force majeure, such as earthquakes, floods, volcanic eruptions, mudslides, lightning strikes, fires, wars, armed conflicts, typhoons, hurricanes, tornadoes, and other extreme weathers. In case of fire, evacuate the building or product area and call the fire department. Do not go back to the fire area.**

**Tighten the screws at the specified torques using proper tools when fastening the product and terminals. Otherwise, the product may be damaged. The damage caused therefrom will not be covered by the warranty.**

**Understand how to use the tools properly first before starting using them, to avoid causing personal injury or product damage.**

## **NOTICE**

**Perform operations on the product only if you have a good understanding of this manual and appropriate tools in hand.**



- Safety instructions in this manual should only serve as a supplement and are not all-encompassing regarding all the norms that need to be followed. All work should be carried out considering the actual situation on the site.
- SUNGROW shall not be held liable for any damage caused by violation of general safe operation requirements, safety standards, and the safety instructions specified in this manual.
- Product installation, operation, and maintenance should be conducted in compliance with applicable local laws, regulations, and specifications. Safety instructions in this manual should only be a supplement to the local laws, regulations, and specifications.
- During the product transport, installation, wiring, and maintenance, etc., the materials and tools prepared by users must meet the requirements of applicable local laws and regulations, safety standards, and other relevant specifications. SUNGROW shall not be held liable for any damage to the product caused by the adoption of materials and tools that fail to meet the above-mentioned requirements.
- Operations on the product, including but not limited to, handling, installing, wiring, powering-on, maintenance, and use of the product, must not be performed by unqualified personnel. SUNGROW shall not be held liable for any damage to the product resulting from operations done by unqualified personnel.
- Where the transport of the product is arranged by users, SUNGROW shall not be held liable for any damage to the product that is caused by users themselves or the third-party transport service providers designated by the users.
- SUNGROW shall not be held liable for any damage to the product caused by the negligence, intent, fault, improper operation, and other behaviors of users or third-party organizations.
- SUNGROW shall not be held liable for any damage to the product arising from reasons unrelated to SUNGROW.

## 1.1 Unpacking and Inspection

### **WARNING**

- **Check all safety signs, warning labels, and nameplates on products.**
- **Ensure that the safety signs, warning labels and nameplates must be clearly visible and cannot be removed or covered before the product is decommissioned.**

**NOTICE**

After receiving the product, check whether the appearance and structural parts of the device are damaged, and check whether the packing list is consistent with the actual ordered product. If there are problems with the above inspection items, do not install the device and contact SUNGROW in time.

## 1.2 Installation Safety

**⚠ DANGER**

Make sure there is no electrical connection before installation.  
Where hole drilling is required during installation, avoid the internal water pipes and electrical wires when drilling.

**⚠ CAUTION**

Improper installation may cause personal injury!

- If the product supports hoisting transport and is hoisted by hoisting tools, ensure no personnel pass or stay beneath the product during the process.
- When handling the product, get prepared for carrying its weight and keep the balance to prevent it from tilting or falling.

**NOTICE**

Before operating the product, check and ensure that the tools to be used have undergone regular maintenance.

## 1.3 Electrical Connection Safety

**⚠ DANGER**

Before electrical connections, make sure that the product is not damaged; otherwise, it may lead to danger!  
Before electrical connections, please make sure that the inverter switch and all switches connected to the inverter are set to "OFF", otherwise electric shock may occur!

**⚠ DANGER**

**Hazardous voltages on the PV string when it is exposed to sunlight!**

- Operators must wear proper personal protective equipment during electrical connections.
- Check and confirm that the DC cables are voltage-free using a measuring instrument before touching them.
- Observe all the safety instructions listed in the documents for the PV string and other relevant documents.
- The inverter must not be connected to a PV string that requires positive or negative grounding.

**⚠ DANGER**

**Battery short circuits can cause excessively high instantaneous current and release significant heat, potentially leading to fires and personal injury. Before performing electrical work on batteries, disconnect them from all power sources.**

**Battery terminals and the cables connecting to the inverter carry fatal voltages. Stay away from the cables or terminals inside the inverter to avoid serious injury or death.**

**Strictly follow all safety instructions provided by the battery manufacturer.**

**⚠ DANGER**

**Danger to life due to high voltages inside the product!**

- Be sure to use specialized insulated tools during wiring.
- Note and observe the warning labels on the product, and perform operations strictly following the safety instructions.
- Observe all the safety instructions listed in this manual and other relevant documents for the product.

**⚠ WARNING**

**Damage to the product caused by incorrect wiring is not covered by the warranty.**

- Electrical connections must be performed by qualified personnel.
- The specification of cables used in the PV power system should meet the relevant requirements. The cables should be properly insulated and firmly connected.

**⚠ WARNING**

- Before connecting the PV connectors to the product, check the positive and negative ends of PV module cables first. Connect the PV connectors to the corresponding terminals on the product only after confirming that the polarity is correct.
- During the installation and operation of the inverter, please ensure that the positive or negative polarities of PV strings do not short-circuit to the ground. Otherwise, an AC or DC short-circuit may occur, resulting in equipment damage. The damage caused by this is not covered by the warranty.
- Do not connect any load between the inverter and the AC circuit breaker, so as to prevent the switch from tripping by mistake.
- Determine the specifications of AC circuit breakers to be used strictly in compliance with the applicable local laws and regulations and safety standards or the recommendation by SUNGROW. Otherwise, the circuit breaker may not open in time in the event of something abnormal, which may then lead to safety incidents.
- The battery interface must be compatible with the inverter. The full voltage range of the battery must fall within the allowable range of the inverter, and the battery voltage must not exceed the maximum allowable DC input voltage of the inverter.

**NOTICE**

- Wiring must be done in compliance with the applicable local grid regulations and relevant safety instructions specified for the PV string.
- Install the external protective grounding cable first when performing the electrical connection and remove the external protective grounding cable last when removing the inverter.

## 1.4 Operation Safety

### **⚠ DANGER**

When laying cables, keep the cables at least 30 mm away from the outer edge of the heat-generating components or areas, so as to protect the insulation layer of cables from aging or getting damaged due to high temperature.

When the product is operating:

- Do not touch the product enclosure;
- Do not plug and unplug any connector on the product;
- Do not touch any wiring terminal of the product. Otherwise, it may lead to electric shocks;
- Do not disassemble or remove any part of the product. Otherwise, it may lead to electric shocks;
- Do not touch any hot part of the device (e.g. heat sink); otherwise, it may cause burns.
- Do not connect or disconnect any individual battery; otherwise, it may lead to burn hazards.
- Do not connect or remove any PV string or any PV module in a string. Otherwise, an electric shock may occur.
- If the inverter is equipped with a DC switch, do not operate it. Otherwise, it may cause device damage or personal injury.

Do not take other actions, such as setting parameters, during the process of firmware update, to avoid update failure.

## 1.5 Maintenance Safety

### **⚠ DANGER**

**Risk of product damage or personal injury due to improper servicing!**

- Before maintenance, disconnect the AC circuit breaker on the grid side and then the DC switch. Verify that the connected battery is de-energized. If a fault that may cause personal injury or device damage is found before maintenance, disconnect the AC circuit breaker and wait until the night before operating the DC switch. Otherwise, a fire inside the product or an explosion may occur, causing personal injuries.
- After the product is powered off for 15 minutes, measure the voltage and current using proper instruments. Perform operation and maintenance of the product wearing proper protective equipment after confirming that there is no voltage or current present.
- Even if the inverter has stopped running, it may still be hot and cause burns. Perform operations on the inverter wearing protective gloves after it cools down.

**⚠ DANGER**

Touching the power grid or the contacts and terminals inside the inverter connected to the power grid may lead to electric shocks!

- Voltage may be present on the grid side. Use a standard voltmeter to check and confirm that it is voltage-free before touching.

**⚠ CAUTION**

To prevent irrelevant personnel from operating the product by mistake or other accidents, please set up highly visible warning signs around the inverter or fence off a warning zone.

**NOTICE**

- If the paint on the inverter enclosure peels off or the enclosure rusts, repair it in time. Otherwise, the product performance may be affected.
- Do not use cleaning agents to clean the inverter. Otherwise, the inverter may be damaged, and the loss caused therefrom will not be covered by the warranty.
- No part inside the product requires maintenance. Therefore, do not open the inverter enclosure (except for the wiring box) or replace any of its internal components without authorization. Otherwise, the damage caused therefrom will not be covered by the warranty.
- To minimize the risk of electric shocks, do not perform maintenance operations that are not specified in this manual. If necessary, contact SUNGROW for maintenance. Losses arising from failure to observe this instruction will not be covered by warranty.
- Do not open the maintenance door in rainy or snowy weather. If it is inevitable, take proper protective measures to avoid the ingress of rainwater and snow into the maintenance compartment; otherwise, the operation of the inverter may be affected.
- Before closing the maintenance door, check whether there is any object left inside the maintenance compartment, such as screws, tools, etc.
- It is recommended for users to use cable sheathing to protect the AC cable. If the cable sheathing is used, make sure it is positioned inside the maintenance compartment.

## 1.6 Disposal Safety

**⚠ WARNING**

Please scrap the product in accordance with relevant local regulations and standards to avoid property damages or personal injuries.

## 2 Product Description

### 2.1 Product Overview

#### Product Model

The model description is as follows : (Taking SH125CX as an example)

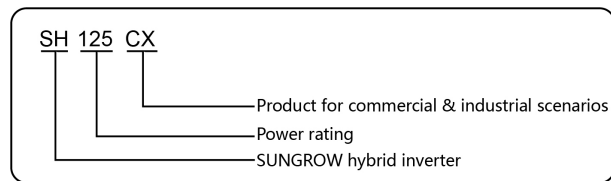

#### Inverter External Design

The external design of the inverter is shown below.

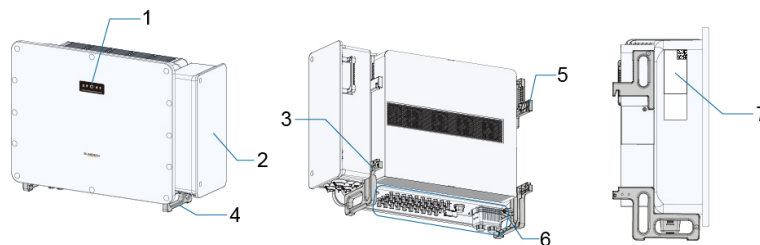

**Figure 2-1** Inverter External Design

\*The figure here is for reference only and the real product may differ.

No.	Item	Description
1	LED indicator	Indicates the current status of the inverter.
2	AC junction box	Used for AC wiring.
3	External grounding terminals	Two grounding terminals are provided. Use at least one of them for grounding.
4	Bottom handles	Two handles, used for inverter handling.
5	Mounting ears	Two, used to hang the inverter onto the mounting-bracket.

No.	Item	Description
6	Wiring area	Includes the DC switch, DC terminals, battery terminals, and communication terminals. For details, please refer to <a href="#">7.2 Terminal Description</a> .
7	Labels	Includes the nameplate, warning labels, and QR code.

**Product Dimensions**

The dimensions of the inverter are shown below.

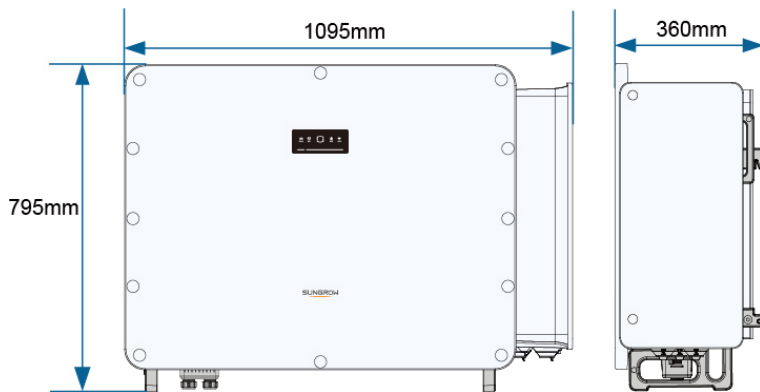







**Weight**

Model	Weight
SH110CX	≤ 128 kg
SH125CX	

**2.2 Symbols on the Product**

Symbol	Description
	Disconnect the inverter from all external power sources before inverter maintenance.
	Burn hazard due to the hot surface that may exceed 60°C.
	Danger to life due to high voltages! After the inverter is disconnected from the external power source, wait at least 15 minutes before touching any of its internal conductive parts.

Symbol	Description
	Installation and operation must only be performed by qualified personnel.
	High voltage hazard. Ensure proper grounding before powering on!
	Comply with RCM certification.
	Read the manual before performing any operation on the inverter.
	Transformerless inverter.
	Do not dispose of the inverter as household waste.
	Read the manual before performing any operation on the inverter.
	CE Declaration of Conformity.

## 2.3 LED Indicators

















As a human-machine interface, the LED indicators on the inverter's front panel display the current operating status of the inverter.

The LED panel is located on the front of the inverter and includes a display and indicator lights.



Figure 2-2 LED Panel

Table 2-1 LED Indicator Status Description

Indicator	Color	Status	Meaning
		Steady on	PV fault
		Steady on	PV outputting power
		Off	PV not outputting power
		Steady on	Battery fault
		Steady on	Battery connected
		Off	Battery not connected
		Steady on	Inverter fault
		Steady on	Inverter operating normally
		Off	The AC and DC power are disconnected.
		Steady on	Inverter operating in grid-connected mode
		Off	Grid connection abnormal
		Steady on	External data communication normal

Indicator	Color	Status	Meaning
		Blink	Communicating via Bluetooth
		Off	No communication

**Battery Status**

Indicator

Refer to "Battery Status Indicator".



**Battery Status Indicator**



The battery status indicator section comprises two indicators: the operation status indicator and the SOC status indicator.









1: Operation status indicator

2: SOC status indicator

**Table 2-2** Operation Status Indicator Description

Color	Status	Meaning
Blue 	Steady on	Battery connection
Grey 	Off	No battery
Red 	Steady on	Battery fault

**Table 2-3** SOC Status Indicator Description

Color	Status	Meaning
		Battery SOC: 0
		0 < Battery SOC ≤ 20%
		20% < Battery SOC ≤ 40%
Blue		40% < Battery SOC ≤ 60%
		60% < Battery SOC ≤ 80%
		Battery SOC > 80%

Color	Status	Meaning
Grey		Battery not connected or fully discharged

 The figures shown are for reference only. The actual product may differ.

## 2.4 DC Switch

The DC switch can safely disconnect the inverter from the PV strings. The inverter is equipped with two DC switches. The two DC switches control two different groups of PV terminals respectively. If the inverter detects a major internal fault (e.g., overvoltage, overcurrent, overtemperature), the DC switch automatically trips to interrupt the DC inputs.

Refer to [11.2.5 DC Switch Maintenance](#) for proper handling when the DC switch trips automatically.

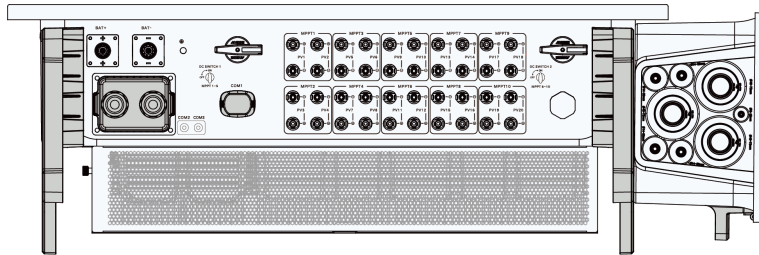

\*The figure shown here is for reference only and the real product may differ.

DC Switch	PV Terminals Controlled by the Switch
DC SWITCH 1	PV1–PV10
DC SWITCH 2	PV11–PV20

## 2.5 Circuit Diagram

The following figure shows the main circuit of the inverter.

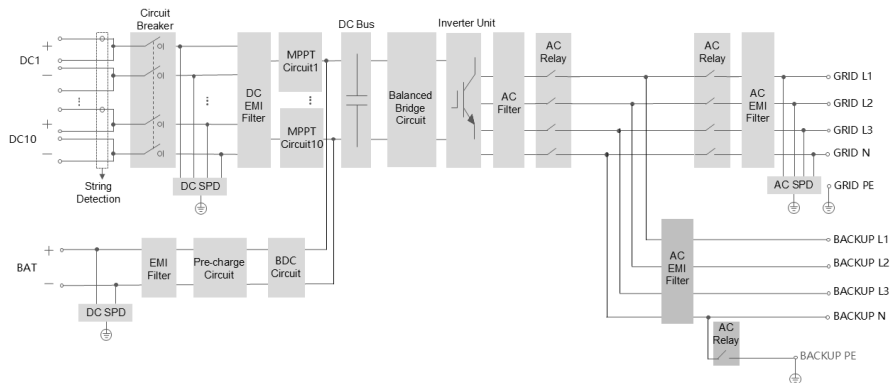

**Figure 2-3** Circuit Diagram

- DC switches can safely disconnect the PV input when necessary to ensure the safe operation of the inverter and the safety of personnel
- EMI filters can filter out the electromagnetic interference inside the inverter to ensure that the inverter meets the requirements of electromagnetic compatibility standards.
- The inverter converts DC into grid-compatible AC current and feeds AC into the grid.
- The AC filter removes high-frequency components from the inverter output current, ensuring the output current meets grid requirements.
- The output relay isolates the inverter's AC output from the grid, allowing the inverter to safely disconnect from the grid during inverter faults or grid faults.
- The AC SPD provides a discharge path for AC side overvoltage, preventing damage to internal inverter circuits caused by overvoltage impact.



The PE wire of Backup terminal is not required for Australia and New Zealand.

**⚠ DANGER**

**If the lightning level exceeds the protection level of the product, surge protection and overvoltage protection may fail, resulting in electric shock and fatal injury!**

## 3 System Application Introduction

### 3.1 System Application Overview

SH110CX, SH125CX are three-phase non-isolated hybrid inverters applicable to both on-grid and off-grid PV systems. After the integration of Energy Management System (EMS), they can control and optimize the energy flow so as to increase the self-consumption of the system.



- The inverter must only be operated with PV strings with class II protection in accordance with IEC 61730, application class A. It is not allowed for the positive pole or the negative pole of the PV strings to be grounded.
- Do not connect any local load between the inverter and the AC circuit breaker.

### 3.2 PV Energy Storage System (PV ESS)

#### **WARNING**

**When designing the system, ensure that the operating ranges of the devices connected to the inverter all satisfy the inverter's requirements for operation.**

#### 3.2.1 PV ESS Introduction

By directly connecting a battery module to the inverter, the conventional PV system can be upgraded to be an Energy Storage System (ESS).

The system is capable of operating off-grid to ensure an emergency power supply for protected loads in the event of a grid interruption or blackout, which may be caused by:

- islanding;
- under-voltage;
- under-frequency or over-frequency.

#### **NOTICE**

- **Under any connection, either grid-connection or off-grid application, please be sure that the potential voltage between N and PE line is not higher than 12V, otherwise, inverter will stop generating power.**
- **The system is not suitable for supplying life-sustaining medical devices. It cannot guarantee backup power in all circumstances.**

### 3.2.2 Backup Function Statement

#### **DANGER**

**This product is not intended to power life-support medical equipment. Power loss may cause life-threatening consequences.**

This disclaimer pertains to general Sungrow policy for inverters described in this document.

1. For hybrid inverters, the electrical setup typically includes connection to both PV arrays and battery modules. If neither PV arrays nor battery modules supply usable power in backup mode, the backup source will automatically shut down. SUNGROW is not liable for any consequences resulting from failure to comply with this guidance.
2. When operating in backup mode, the inverter supports a 6 kW single-phase half-wave load. For details regarding the inverter's load carrying capacity, please contact SUNGROW.
3. In general, backup switchover time of single inverter is less than 10 ms. However, external factors or local grid codes may prevent backup mode from being enabled. Therefore, users must be aware of the following conditions and comply with the relevant operating instructions:
  - Do not connect loads requiring continuous and stable power supply.
  - Do not connect loads with total capacity exceeding the maximum backup capacity.
  - Due to the limitations of the battery's own state, the battery current may be restricted by various factors, including but not limited to temperature and weather conditions.

#### **Backup Overload Protection Statement**

When overload protection is triggered, the inverter fault needs to be cleared manually. Try to minimize the backup load power or remove loads that may cause high inrush current.



- During commissioning before the inverter operates with load, confirm that the load does not exceed the rated load. Exceeding the rated load will cause damage to the inverter.
- After a bypass overload fault is reported, manually disconnect the external load circuit breaker, modify the load circuit and power, confirm the load does not exceed the rated load, manually clear the fault, and then restart.

### 3.2.3 Energy Management

The battery discharges to power the loads. If battery power is insufficient, the grid supplies both backup and general loads.

When the grid is present, the inverter activates the bypass function, and backup loads are connected directly to the grid through the inverter's internal bypass switch.

If the smart meter is malfunctioning or not installed while the inverter operates normally, the battery can not charge or discharge. Under these circumstances, feed-in power settings will be invalid, and the DO function in optimized mode will also be disabled.

### Daytime Energy Management

The energy management system (EMS) operates in self-consumption mode by default.

- Scenario 1: PV generation  $\geq$  Load consumption
  - PV power is first used for loads, with the surplus used to charge the battery
  - If the battery is fully charged, excess power is fed into the grid. Feed-in power will not exceed the limit set in the initial configuration.

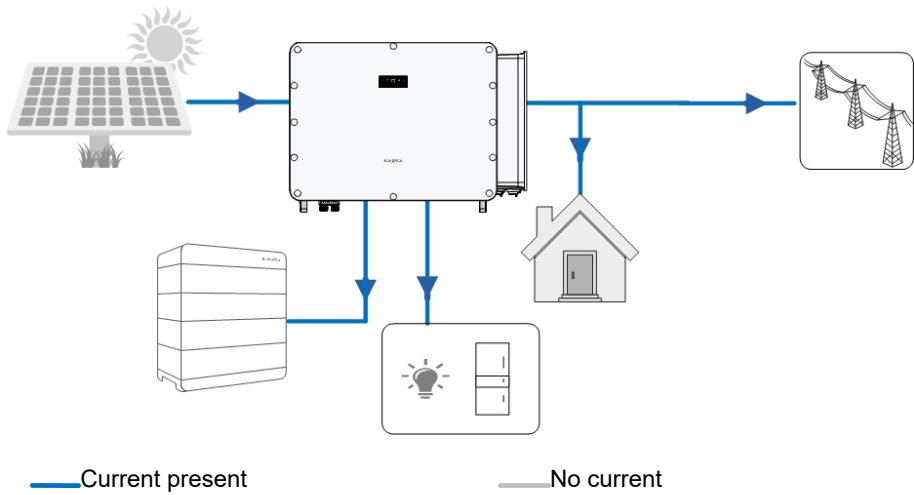

- Scenario 2: PV generation  $<$  Load consumption
  - The battery discharges to cover the power deficit during the permitted discharge period.
  - If the combined PV and battery power still cannot meet the load demand, the inverter will draw power from the grid.

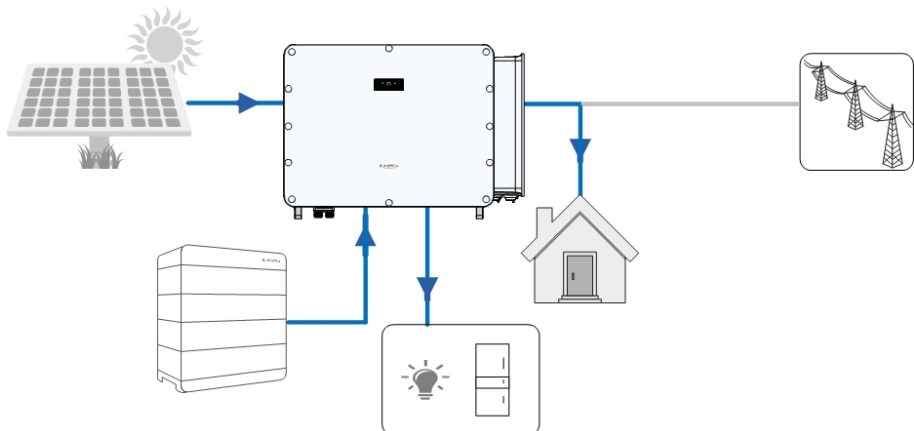

— Current present

— No current

### Nighttime Energy Management

At night, the battery discharges to power the loads. If battery power is insufficient, the grid also supplies power to the loads.

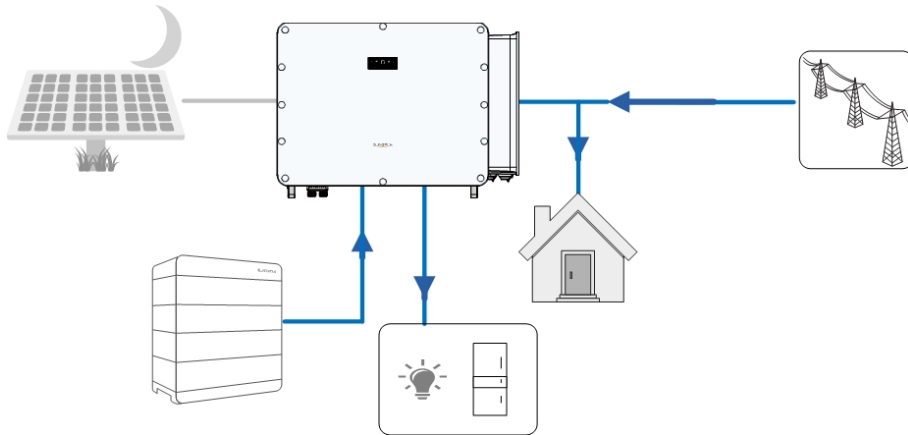

— Current present

— No current

At night, when the battery is depleted, the system enters standby mode with all power supplied by the grid.

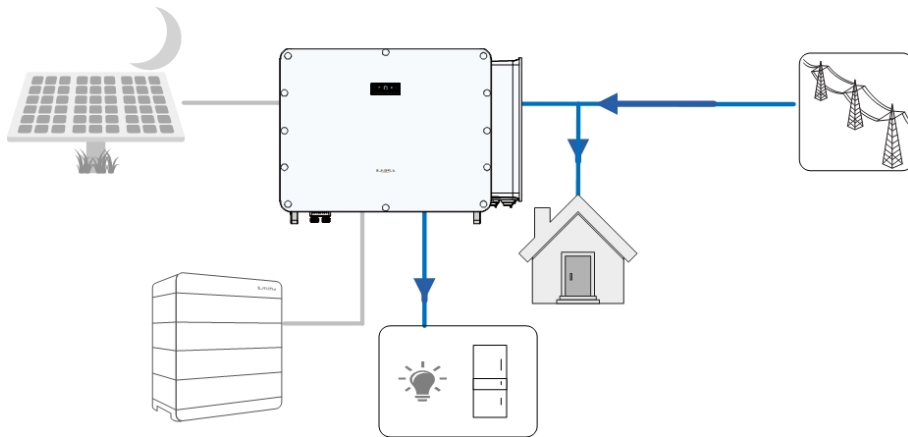

— Current present

— No current

### 3.3 System Application Scenarios



Scenarios not mentioned here are considered unsupported by default. For additional application requirements, please contact Sungrow technical support for confirmation.

#### 3.3.1 Pure Grid-connected System Scenario

##### 3.3.1.1 System Overview

The pure on-grid system scenario is applicable to regions with a stable utility grid, where feed power to the grid may be restricted. Additional loads can be connected to the **grid port** to increase the self-consumption rate of PV generation. In this scenario, up to 24 hybrid inverters can be configured. No loads are connected to the **backup port**. In the event of a grid outage, the system will not supply power to the loads. When PV is connected, batteries are optional.

Pure grid-connected system: All loads are connected to the **GRID** port, and the system operates in grid-connected mode.

Scenario	Single-inverter/Multi-inverter system configuration					
	PV module s <sup>(1)</sup>	Battery <sup>(1)</sup>	Smart meter	Logger 1000	Manual change over switch	Grid
Pure grid-connected system (no backup)	○	○	●	●	✘	●

● Required, ○ Optional, ✘ Not required

(1) In this scenario, either only PV or only the battery may be connected, but not both disconnected.

##### 3.3.1.2 Single-inverter System

###### 3.3.1.2.1 System Configuration

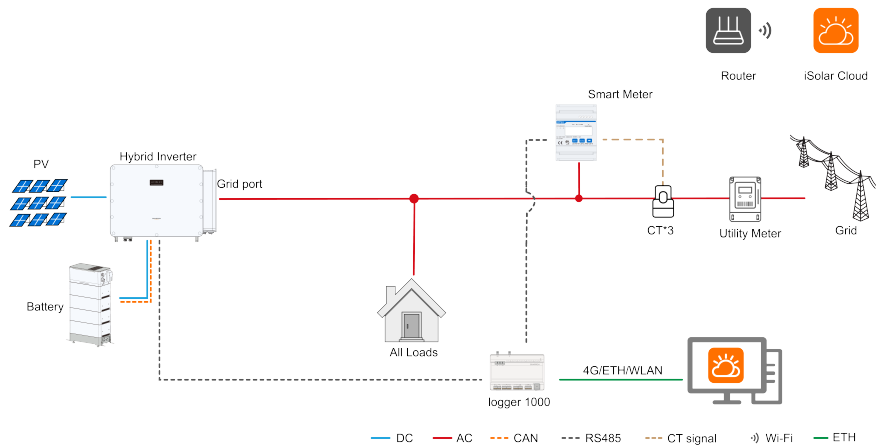

Component	Model/Type	Quantity	Remarks
Hybrid inverter	SH110/125CX	1	Key component of the energy storage system
Smart meter	Refer to <a href="#">4.2.7 Meter Management</a>	1	Refer to <a href="#">4.2.7 Meter Management</a> .
Current transformer (CT)	Determined based on grid connection point current.	3	<ul style="list-style-type: none"> <li>CT compatible with Smart meter is required.</li> <li>CT specifications shall be determined based on grid connection point current.</li> </ul>
Communication device	Logger1000 (COM100)	1	/
Terminal resistor	120 Ω	2	<ul style="list-style-type: none"> <li>When the smart meter communication cable exceeds 10m, a 120Ω resistor must be connected in parallel at the meter terminals.</li> <li>When communication between the battery and the inverter, it is recommended to connect a 120Ω resistor in parallel at the CAN communication port of the battery farthest from the inverter.</li> </ul>

Component	Model/Type	Quantity	Remarks
AC miniature circuit breaker (MCB): Grid port	200A/400V Type A ( $I_{max}$ : 200A)	1	<ul style="list-style-type: none"> <li>To be purchased by the customer. Select MCB with appropriate specifications based on actual needs, including wiring plan, number of loads, and inverter capacity.</li> <li>The circuit breaker must be installed on the grid port of each hybrid inverter.</li> </ul>
PV	/	/	Optional; batteries are not required when PV is connected.
Battery	Refer to <a href="#">4.2.6 Battery Management</a>	/	<ul style="list-style-type: none"> <li>Optional, to be purchased by the customer.</li> <li>Required if PV is not configured.</li> </ul>

### 3.3.1.2.2 System Settings



It is recommended to use the local access of Logger1000 for system commissioning. For Logger1000 login, network configuration, plant creation, device addition, etc., please refer to [Logger1000 User Manual](#).

The corresponding sections in [Logger1000 User Manual](#) for parameter setting operations are listed in the table below:

No.	Parameter setting	Reference section title
1	Set energy management mode	Select Energy Management Operating Mode
2	Enable Feed-in power limit: Total active power control or Per-phase active power control	Grid-Connected Power Control
3	Set Feed-in power limit parameters	
4	Set Purchase energy with limited power	
5	Set CT transformation ratio	<ul style="list-style-type: none"> <li>Add meter: Adding a Meter</li> <li>Setting CT transformation ratio:</li> </ul>

No.	Parameter setting	Reference section title
		Configuring Parameters for Meter

### 3.3.1.3 Multi-inverter System

#### 3.3.1.3.1 System Configuration

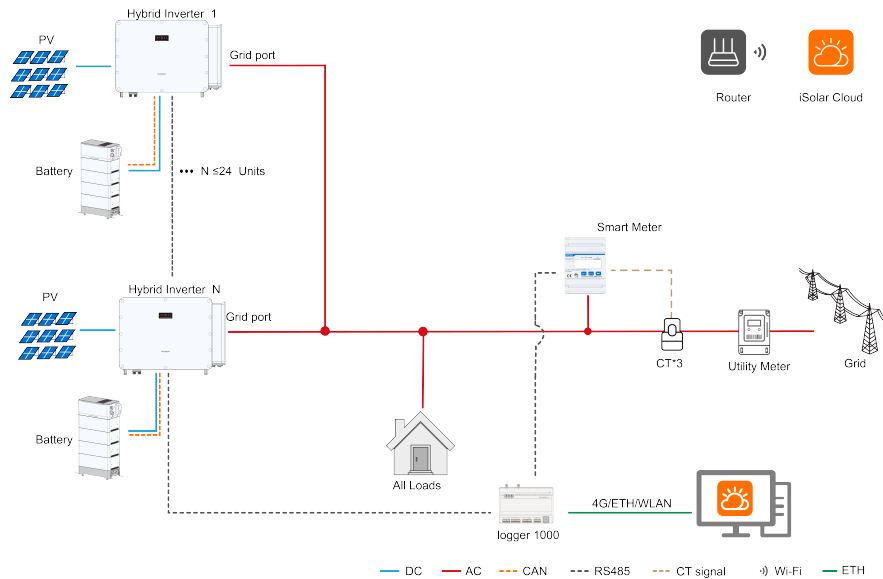

Component	Model/Type	Quantity	Remarks
Hybrid inverter	SH110CX/ SH125CX	≤24	<ul style="list-style-type: none"> <li>Key component of the energy storage system.</li> <li>Different inverter models can be operated in parallel.</li> </ul>
Smart meter	Refer to <a href="#">4.2.7 Meter Management</a>	1	Refer to <a href="#">4.2.7 Meter Management</a> .
Current transformer (CT) or Rogowski coil	Determined based on grid connection point current.	3	<ul style="list-style-type: none"> <li>CT compatible or Rogowski coil with Smart meter is required.</li> <li>CT specifications shall be determined based on grid connection point current.</li> </ul>
Communication device	Logger1000 (COM100)	1	/

Component	Model/Type	Quantity	Remarks
Terminal resistor	120 Ω	2	<ul style="list-style-type: none"> <li>When the smart meter communication cable exceeds 10m, a 120Ω resistor must be connected in parallel at the meter terminals.</li> <li>When communication between the battery and the inverter, it is recommended to connect a 120Ω resistor in parallel at the CAN communication port of the battery farthest from the inverter.</li> </ul>
AC miniature circuit breaker (MCB): Grid port	200A/400V Type A (I <sub>max</sub> : 200A)	1 pcs for per inverter	<ul style="list-style-type: none"> <li>To be purchased by the customer. Select MCB with appropriate specifications based on actual needs, including wiring plan, number of loads, and inverter capacity.</li> <li>The circuit breaker must be installed on the grid port of each hybrid inverter.</li> </ul>
PV	/	/	Optional; batteries are not required when PV is connected.
Battery	Refer to <a href="#">4.2.6 Battery Management</a>	/	<ul style="list-style-type: none"> <li>Optional, to be purchased by the customer.</li> <li>Required if PV is not configured.</li> </ul>

### 3.3.1.3.2 System Settings

The parameter settings for the multi-inverter system are the same as those for the single-inverter system in a pure grid-connected scenario. Refer to [3.3.1.2.2 System Settings](#).

## 3.3.2 On/off-grid System Scenario

### 3.3.2.1 System Overview

The on/off-grid system must be connected to the utility grid through the **GRID** port of the inverter. When the grid is normal, the system operates in on-grid mode. When a grid fault occurs, the system automatically switches to off-grid mode. During off-grid operation, loads connected to the **GRID** port will lose power, while loads connected to the **BACKUP** port can continue operating normally.

On-/off-grid system: Loads can be connected to both the **GRID** port and the **BACKUP** port. The system supports both on-grid and off-grid operation, with automatic grid/off-grid switching performed by the inverter.



For details regarding the inverter's load carrying capacity, please contact SUNGROW.

Single-inverter system configuration						
Scenario	PV modules	Battery	Smart meter	Logger 1000	Manual change over switch	Grid
Partial backup	○	●	●	●	✘	●
Plant-level backup	○	●	●	●	● <sup>(1)</sup>	●
Grid port retrofit / AC-coupled system	○	●	●	●	✘	●

Multi-inverter system configuration						
Scenario	PV modules	Battery	Smart meter	Logger 1000	Manual change over switch	Grid
Partial backup – one backup port one load ( $\leq 24$ units)	○	●	●	●	✘	●
Partial backup – all backup ports one	○	●	●	●	✘	●

Multi-inverter system configuration						
Scenario	PV module s	Battery	Smart meter	Logger 1000	Manual change over switch	Grid
load (2 units)						
Plant-level backup (2 units)	○	●	●	●	● <sup>(1)</sup>	●
Grid port retrofit / AC- coupled system (2 units)	○	●	●	●	✘	●

● Required, ○ Optional, ✘ Not required

(1) The manual changeover switch shall be provided by the customer.

### 3.3.2.2 Single-inverter System

#### 3.3.2.2.1 Partial backup

##### 3.3.2.2.1.1 System configuration

The partial backup scenario is applicable to areas where the grid is unstable. In the event of a grid failure, the loads connected to the grid are no longer supplied with energy. A long-period grid outage may cause serious consequences to some key loads, such as emergency light, refrigerator, etc. A possible solution for bridging this supply gap is to connect the emergency loads to the **BACKUP** port on the hybrid inverter.

If a grid failure happens, the hybrid system will be disconnected from the utility grid. A backup grid then is created and the PV system can thus continue to supply power to the emergency loads connected to the **BACKUP** port.

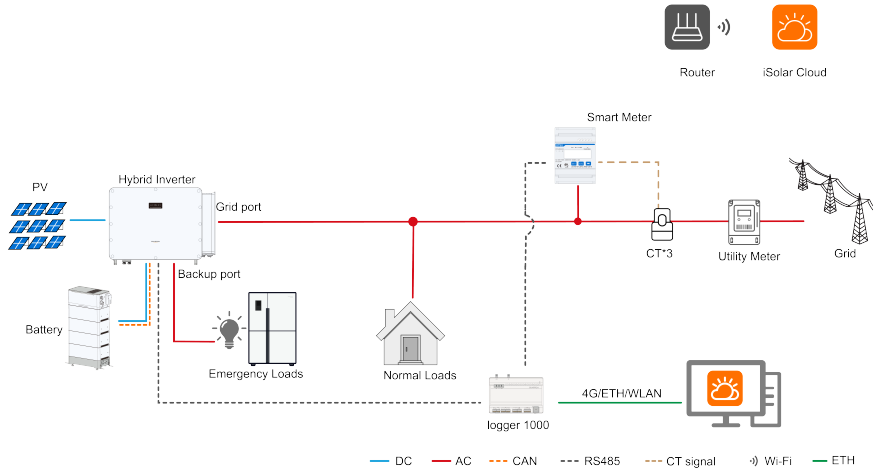

Component	Model/Type	Quantity	Remarks
Hybrid inverter	SH110/125CX	1	Key component of the energy storage system.
Smart meter	Refer to <a href="#">4.2.7 Meter Management</a>	1	Refer to <a href="#">4.2.7 Meter Management</a> .
Current transformer (CT)	Determined based on grid connection point current.	3	<ul style="list-style-type: none"> <li>CT compatible with Smart meter is required.</li> <li>CT specifications shall be determined based on grid connection point current.</li> </ul>
Communication device	Logger1000 (COM100)	1	/
Terminal resistor	120 Ω	2	<ul style="list-style-type: none"> <li>When the smart meter communication cable exceeds 10m, a 120Ω resistor must be connected in parallel at the meter terminals.</li> <li>When communication between the battery and the inverter, it is recommended to connect a 120Ω resistor in parallel at the CAN communication port of the battery farthest from the inverter.</li> </ul>

Component	Model/Type	Quantity	Remarks
AC miniature circuit breaker (MCB): Grid port	320-400A/ 400V Type A (I <sub>max</sub> : 400A)	1 pcs for per hybrid inverter	<ul style="list-style-type: none"> <li>To be purchased by the customer. Select MCB with appropriate rated current based on actual needs, including wiring plan, number of loads, and inverter capacity.</li> </ul>
AC miniature circuit breaker (MCB): Backup port	250A/ 400V Type A (I <sub>max</sub> : 250A)	1 pcs for per hybrid inverter	<ul style="list-style-type: none"> <li>The circuit breaker must be installed on both the grid port and the backup port of the hybrid inverter.</li> </ul>
PV	/	/	Optional configuration; the hybrid inverter may operate without PV.
Battery	Refer to <a href="#">4.2.6 Battery Management</a>	/	Battery connection is strongly recommended; to be purchased separately.

### 3.3.2.2.1.2 System settings



It is recommended to use the local access of Logger1000 for system commissioning. For Logger1000 login, network configuration, plant creation, device addition, etc., please refer to [Logger1000 User Manual](#).

The corresponding sections in [Logger1000 User Manual](#) for parameter setting operations are listed in the table below:

No.	Parameter setting	Reference section title
1	Set energy management mode	Select Energy Management Operating Mode
2	Enable Feed-in power limit: Total active power control or Per-phase active power control	Grid-Connected Power Control
3	Set Feed-in power limit parameters	
4	Set Purchase energy with limited power	System Power Backup
5	Enable Off-grid mode	
6	Set Backup SOC for off-grid operation	

No.	Parameter setting	Reference section title
7	Set CT transformation ratio	<ul style="list-style-type: none"> <li>Add meter: Adding a Meter</li> <li>Setting CT transformation ratio: Configuring Parameters for Meter</li> </ul>

### 3.3.2.2.2 Plant-level backup

#### 3.3.2.2.2.1 System configuration

In this scenario, all plant loads are connected to the hybrid inverter’s **BACKUP** port via a manual changeover switch. When the inverter requires maintenance, the power supply can be switched from the backup port to the grid through the manual changeover switch, ensuring uninterrupted power supply to the plant-level loads.

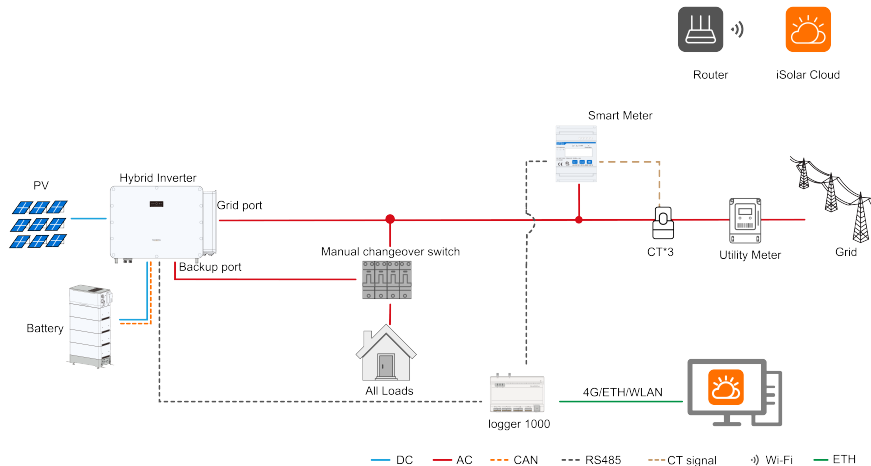

Component	Model/Type	Quantity	Remarks
Hybrid inverter	SH110/125CX	1	Key component of the energy storage system.
Smart meter	Refer to <a href="#">4.2.7 Meter Management</a>	1	Refer to <a href="#">4.2.7 Meter Management</a> .
Current transformer (CT)	Determined based on grid connection point current.	3	<ul style="list-style-type: none"> <li>CT compatible with Smart meter is required.</li> <li>CT specifications shall be determined based on grid connection point current.</li> </ul>

Component	Model/Type	Quantity	Remarks
Communication device	Logger1000 (COM100)	1	/
Terminal resistor	120 Ω	2	<ul style="list-style-type: none"> <li>When the smart meter communication cable exceeds 10m, a 120Ω resistor must be connected in parallel at the meter terminals.</li> <li>When communication between the battery and the inverter, it is recommended to connect a 120Ω resistor in parallel at the CAN communication port of the battery farthest from the inverter.</li> </ul>
Manual changeover switch <sup>(1)</sup>	320~400A/400V	1	<ul style="list-style-type: none"> <li>To be purchased by the customer. Used for plant-level backup.</li> <li>Switch the power supply for all loads from the inverter to the grid when the inverter requires maintenance.</li> </ul>
AC miniature circuit breaker (MCB): Grid port	320-400A/400V Type A (I <sub>max</sub> : 400A)	1 pcs for per hybrid inverter	<ul style="list-style-type: none"> <li>To be purchased by the customer. Select MCB with appropriate rated current based on actual needs, including wiring plan, number of loads, and inverter capacity.</li> </ul>
AC miniature circuit breaker (MCB): Backup port	250A/400V Type A (I <sub>max</sub> : 250A)	1 pcs for per hybrid inverter	<ul style="list-style-type: none"> <li>The circuit breaker must be installed on both the grid port and the backup port of the hybrid inverter.</li> </ul>
PV	/	/	Optional configuration; the hybrid inverter may operate without PV.
Battery	Refer to <a href="#">4.2.6 Battery Management</a>	/	Battery connection is strongly recommended; to be purchased separately.

(1) The manual changeover switch should be 4-pole single-pole double-throw type, to be purchased by the customer

### 3.3.2.2.2 System settings

The parameter settings for the single-inverter system in a plant-level backup scenario are the same as those for the single-inverter system in a Partial backup scenario. Refer to [3.3.2.2.1.2 System settings](#).

### 3.3.2.2.3 Grid Port Retrofit/AC Coupling

#### 3.3.2.2.3.1 System configuration

If a three-phase PV inverter has already been installed in the existing system, the system can be upgraded to a PV & storage system by adding hybrid inverters and batteries. The energy storage system maximizes the utilization of PV generation, increases the self-consumption rate, and reduces electricity costs.

Grid port retrofit refers to paralleling the AC terminals of the existing PV inverter with the **GRID** port of the hybrid inverter, as shown in the figures below.

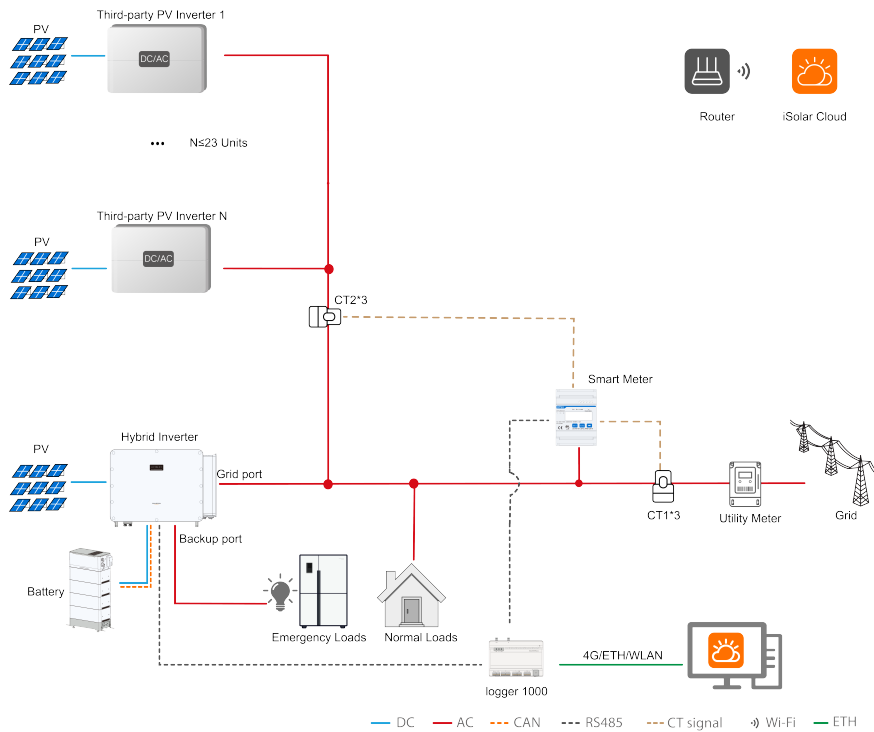

**Figure 3-1** Grid Port Retrofit (Third-Party PV Inverter)

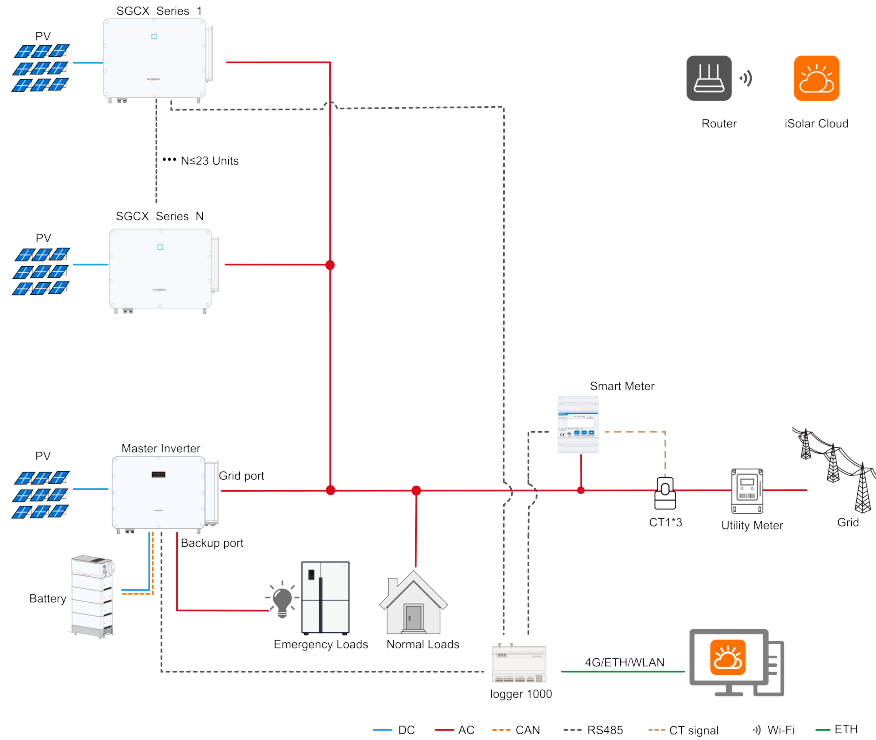

**Figure 3-2** Grid Port Retrofit (Sungrow PV Inverter)

Component	Model/Type	Quantity	Remarks
Hybrid inverter	SH110CX/ SH125CX	1	Key component of the energy storage system.
PV inverter	<ul style="list-style-type: none"> <li>Sungrow: SG50CX/ SG110X/ SG50CX-P2/ SG110CX-P2/ SG125CX-P2</li> <li>Third-party PV inverter</li> </ul>	≤23	Sungrow PV inverters and third-party PV inverters must not be mixed in the same system
Smart meter <sup>(1)</sup>	Refer to <a href="#">4.2.7 Meter Management</a>	1	Refer to <a href="#">4.2.7 Meter Management</a> .
Current transformer (CT)	Determined by grid	<ul style="list-style-type: none"> <li>Sungrow PV</li> </ul>	<ul style="list-style-type: none"> <li>CT compatible with Smart meter is required.</li> </ul>

Component	Model/Type	Quantity	Remarks
	connection point current	inverter (SGCX):3 • Third-party PV inverter :6 <sup>(2)</sup>	<ul style="list-style-type: none"> <li>For third-party PV inverter system, the specifications of CT2 should be determined by current at PV inverter parallel point.</li> <li>For third-party PV inverter system, the specifications of CT1 and CT2 shall be consistent.</li> </ul>
Communication device	Logger1000 (COM100)	1	/
Terminal resistor	120 Ω	2	<ul style="list-style-type: none"> <li>When the smart meter communication cable exceeds 10m, a 120Ω resistor must be connected in parallel at the meter terminals.</li> <li>When communication between the battery and the inverter, it is recommended to connect a 120Ω resistor in parallel at the CAN communication port of the battery farthest from the inverter.</li> </ul>
AC miniature circuit breaker (MCB): Grid port	320-400A/ 400V Type A (I <sub>max</sub> : 400A)	1 pcs for per hybrid inverter	<ul style="list-style-type: none"> <li>To be purchased by the customer. Select MCB with appropriate rated current based on actual needs, including wiring plan, number of loads, and inverter capacity.</li> </ul>
AC miniature circuit breaker (MCB): Backup port	250A/ 400V Type A (I <sub>max</sub> : 250A)	1 pcs for per hybrid inverter	<ul style="list-style-type: none"> <li>The circuit breaker must be installed on both the grid port and the backup port of the hybrid inverter.</li> </ul>
PV	/	/	Optional configuration; the hybrid inverter may operate without PV.

Component	Model/Type	Quantity	Remarks
Battery	Refer to <a href="#">4.2.6 Battery Management</a>	/	Battery connection is strongly recommended; to be purchased separately.

(1) When using third-party PV inverter, the dual-channel smart meter DTSU666-20 is required.

(2) For third-party PV inverter system, 6 CTs are required, with CT2 connected to the parallel point of the PV inverters.

### 3.3.2.2.3.2 System settings



It is recommended to use the local access of Logger1000 for system commissioning. For Logger1000 login, network configuration, plant creation, device addition, etc., please refer to [Logger1000 User Manual](#).

The corresponding sections in [Logger1000 User Manual](#) for parameter setting operations are listed in the table below:

No.	Parameter setting	Reference section title
1	Set energy management mode	Select Energy Management Operating Mode
2	Enable Feed-in power limit: Total active power control or Per-phase active power control	
3	Set Feed-in power limit parameters	Grid-Connected Power Control
4	For third-party retrofit systems, set Third-party power generation system	
5	Set Purchase energy with limited power	
6	Enable Off-grid mode	System Power Backup
7	Set Backup SOC for off-grid operation	
8	Set CT transformation ratio	<ul style="list-style-type: none"> <li>Add meter: Adding a Meter</li> <li>Setting CT transformation ratio: Configuring Parameters for Meter</li> </ul>

### 3.3.2.3 Multi-inverter System

#### 3.3.2.3.1 Partial backup(one backup port one load ≤24 units)

##### 3.3.2.3.1.1 System configuration

One backup port one load refers to a configuration in which the **GRID** ports of the hybrid inverters are connected in parallel to the utility grid, while the **BACKUP** ports are independently connected to emergency loads.

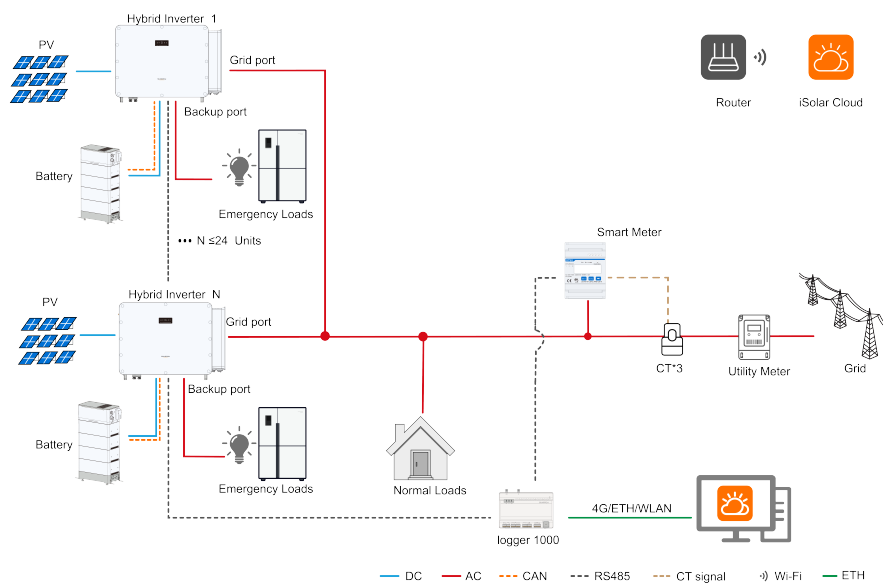

Component	Model/Type	Quantity	Remarks
Hybrid inverter	SH110/125CX	≤24	<ul style="list-style-type: none"> <li>Key component of the energy storage system.</li> <li>Different inverter models can be connected in parallel.</li> </ul>
Smart meter	Refer to <a href="#">4.2.7 Meter Management</a>	1	Refer to <a href="#">4.2.7 Meter Management</a> .
Current transformer (CT) or Rogowski coil	Determined based on grid connection point current.	3	<ul style="list-style-type: none"> <li>CT compatible or Rogowski coil with Smart meter is required.</li> <li>CT specifications shall be determined based on grid connection point current.</li> </ul>
Communication device	Logger1000 (COM100)	1	/

Component	Model/Type	Quantity	Remarks
Terminal resistor	120 Ω	2	<ul style="list-style-type: none"> <li>When the smart meter communication cable exceeds 10m, a 120Ω resistor must be connected in parallel at the meter terminals.</li> <li>When communication between the battery and the inverter, it is recommended to connect a 120Ω resistor in parallel at the CAN communication port of the battery farthest from the inverter.</li> </ul>
AC miniature circuit breaker (MCB): Grid port	320-400A/ 400V Type A (I <sub>max</sub> : 400A)	1 pcs for per hybrid inverter	<ul style="list-style-type: none"> <li>To be purchased by the customer. Select MCB with appropriate rated current based on actual needs, including wiring plan, number of loads, and inverter capacity.</li> </ul>
AC miniature circuit breaker (MCB): Backup port	250A/ 400V Type A (I <sub>max</sub> : 250A)	1 pcs for per hybrid inverter	<ul style="list-style-type: none"> <li>The circuit breaker must be installed on both the grid port and the backup port of the hybrid inverter.</li> </ul>
PV	/	/	Optional configuration; the hybrid inverter may operate without PV.
Battery	Refer to <a href="#">4.2.6 Battery Management</a>	/	Battery connection is strongly recommended; to be purchased separately.

### 3.3.2.3.1.2 System settings

The parameter settings for the multi-inverter system in a Partial backup scenario are the same as those for the single-inverter system in a Partial backup scenario. Refer to [3.3.2.2.1.2 System settings](#).

### 3.3.2.3.2 Partial backup (all backup ports one load, 2 units)

#### 3.3.2.3.2.1 System configuration

All backup ports one load refers to a configuration in which the **grid** ports of the hybrid inverter are connected in parallel to the utility grid, while the **backup** ports are paralleled and connected to critical emergency loads. By paralleling the backup ports, more emergency loads can be connected, improving the system's self-consumption rate.

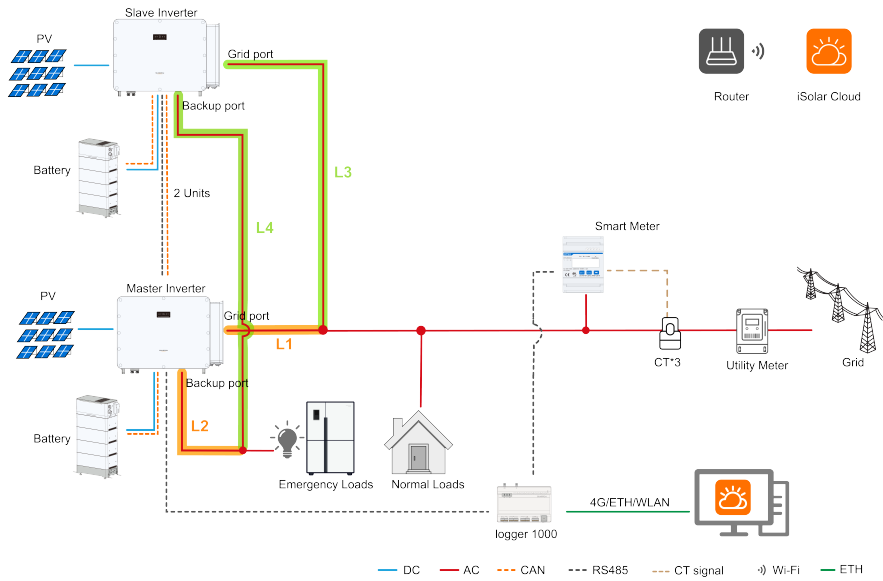

**i** The total length of AC cable from the inverter's grid/backup port to the busbar for each inverter is recommended to be the same ( $L1+L2=L3+L4$ ).

Component	Model/Type	Quantity	Remarks
Hybrid inverter	SH110/125CX	2	<ul style="list-style-type: none"> <li>Key component of the energy storage system.</li> <li>Paralleled hybrid inverters must be of the same model.</li> </ul>
Smart meter	Refer to <a href="#">4.2.7 Meter Management</a>	1	Refer to <a href="#">4.2.7 Meter Management</a> .
Current transformer (CT)	Determined based on grid connection point current.	3	<ul style="list-style-type: none"> <li>CT compatible with Smart meter is required.</li> <li>CT specifications shall be determined based on grid connection point current.</li> </ul>
Communication device	Logger1000 (COM100)	1	/
Terminal resistor	120 Ω	2	<ul style="list-style-type: none"> <li>When the smart meter communication cable exceeds 10m, a 120Ω resistor must be connected in parallel at the meter terminals.</li> </ul>

Component	Model/Type	Quantity	Remarks
			<ul style="list-style-type: none"> <li>When communication between the battery and the inverter, it is recommended to connect a 120Ω resistor in parallel at the CAN communication port of the battery farthest from the inverter.</li> </ul>
AC miniature circuit breaker (MCB): Grid port	320-400A/ 400V Type A (I <sub>max</sub> : 400A)	1 pcs for per hybrid inverter	<ul style="list-style-type: none"> <li>To be purchased by the customer. Select MCB with appropriate rated current based on actual needs, including wiring plan, number of loads, and inverter capacity.</li> </ul>
AC miniature circuit breaker (MCB): Backup port	250A/ 400V Type A (I <sub>max</sub> : 250A)	1 pcs for per hybrid inverter	<ul style="list-style-type: none"> <li>The circuit breaker must be installed on both the grid port and the backup port of the hybrid inverter.</li> </ul>
PV	/	/	Optional configuration; the hybrid inverter may operate without PV.
Battery <sup>(1)</sup>	Refer to <a href="#">4.2.6 Battery Management</a>	/	Battery connection is strongly recommended; to be purchased separately.

(1) In this scenario, the battery capacity configured for each inverter must be consistent.

### 3.3.2.3.2.2 System settings



It is recommended to use the local access of Logger1000 for system commissioning. For Logger1000 login, network configuration, plant creation, device addition, etc., please refer to [Logger1000 User Manual](#).

The corresponding sections in [Logger1000 User Manual](#) for parameter setting operations are listed in the table below:

No.	Parameter setting	Reference section title
1	Enable Master-slave operating mode and set master-slave parameters	Configuring Parameters for Inverters
2	Set energy management mode	Select Energy Management Operating Mode

No.	Parameter setting	Reference section title
3	Enable Feed-in power limit: Total active power control or Per-phase active power control	Grid-Connected Power Control
4	Set Feed-in power limit parameters	
5	Set Purchase energy with limited power	
6	Enable Off-grid mode	System Power Backup
7	Set Backup SOC for off-grid operation	
8	Set CT transformation ratio	<ul style="list-style-type: none"> <li>• Add meter: Adding a Meter</li> <li>• Setting CT transformation ratio: Configuring Parameters for Meter</li> </ul>

### 3.3.2.3.3 Plant-level backup (all backup ports one load, 2 units)

#### 3.3.2.3.3.1 System configuration

In this scenario, all plant loads are connected to the hybrid inverter's **BACKUP** port via a manual changeover switch. When the inverter requires maintenance, the power supply can be switched from the backup port to the grid through the manual changeover switch, ensuring uninterrupted power supply to the plant-level loads.

In this scenario, the **BACKUP** ports of 2 hybrid inverters of the same model can be connected in parallel.



- The total power of connected loads must not exceed the inverter's maximum backup output capacity.
- For details regarding the inverter's load carrying capacity, please contact SUNGROW.

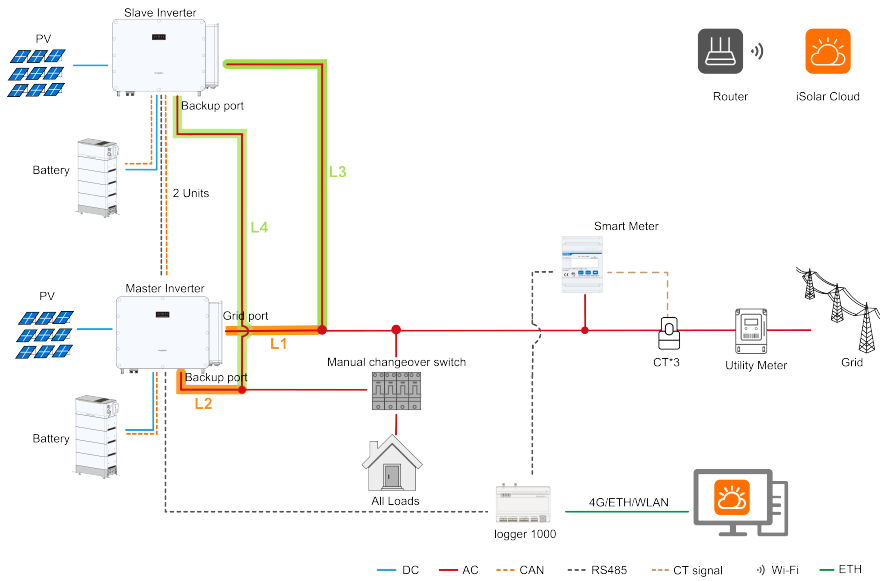

**i** The total length of AC cable from the inverter's grid/backup port to the busbar for each inverter is recommended to be the same ( $L1+L2=L3+L4$ ).

Component	Model/Type	Quantity	Remarks
Hybrid inverter	SH110CX/ SH125CX	2	<ul style="list-style-type: none"> <li>Key component of the energy storage system.</li> <li>Paralleled hybrid inverters must be of the same model.</li> </ul>
Smart meter	Refer to <a href="#">4.2.7 Meter Management</a>	1	Refer to <a href="#">4.2.7 Meter Management</a> .
Current transformer (CT)	Determined based on grid connection point current.	3	<ul style="list-style-type: none"> <li>CT compatible with Smart meter is required.</li> <li>CT specifications shall be determined based on grid connection point current.</li> </ul>
Communication device	Logger1000 (COM100)	1	/
Terminal resistor	120 Ω	2	<ul style="list-style-type: none"> <li>When the smart meter communication cable exceeds 10m, a 120Ω resistor must be connected in parallel at the meter terminals.</li> </ul>

Component	Model/Type	Quantity	Remarks
			<ul style="list-style-type: none"> <li>When communication between the battery and the inverter, it is recommended to connect a 120Ω resistor in parallel at the CAN communication port of the battery farthest from the inverter.</li> </ul>
Manual changeover switch	640~800A/ 400V	1	<ul style="list-style-type: none"> <li>To be purchased by the customer. Used for plant-level backup.</li> <li>Switch the power supply for all loads from the inverter to the grid when the inverter requires maintenance.</li> </ul>
AC miniature circuit breaker (MCB): Grid port	320-400A/ 400V Type A (I <sub>max</sub> : 400A)	1 pcs for per hybrid inverter	<ul style="list-style-type: none"> <li>To be purchased by the customer. Select MCB with appropriate rated current based on actual needs, including wiring plan, number of loads, and inverter capacity.</li> </ul>
AC miniature circuit breaker (MCB): Backup port	250A/ 400V Type A (I <sub>max</sub> : 250A)	1 pcs for per hybrid inverter	<ul style="list-style-type: none"> <li>The circuit breaker must be installed on both the grid port and the backup port of the hybrid inverter.</li> </ul>
PV	/	/	Optional configuration; the hybrid inverter may operate without PV.
Battery <sup>(1)</sup>	Refer to <a href="#">4.2.6 Battery Management</a>	/	Battery connection is strongly recommended; to be purchased separately.

(1) In this scenario, the battery capacity configured for each inverter must be consistent.

### 3.3.2.3.3.2 System settings

The parameter settings for the multi-inverter system in a Plant-level backup scenario are the same as those for the multi-inverter system in a Partial backup (all backup ports one load, 2 units) scenario. Refer to [3.3.2.3.2.2 System settings](#).

### 3.3.2.3.4 Grid Port Retrofit/AC Coupling

### 3.3.2.3.4.1 System configuration

If a three-phase PV inverter has already been installed in the existing system, the system can be upgraded to a PV & storage system by adding hybrid inverters and batteries. The energy storage system maximizes the utilization of PV generation, increases the self-consumption rate, and reduces electricity costs.

Grid port retrofit refers to paralleling the AC terminals of the existing PV inverter with the **GRID** port of the hybrid inverter, while the backup ports of two hybrid inverters of the same model are connected in parallel, as shown in the figures below.

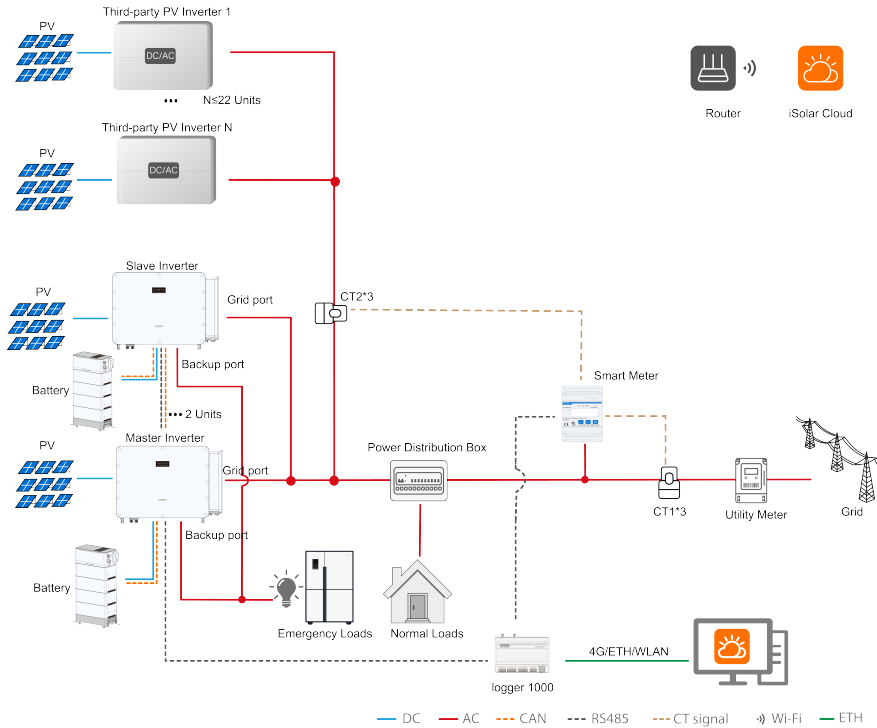

Figure 3-3 Grid Port Retrofit (Third-Party PV Inverter)

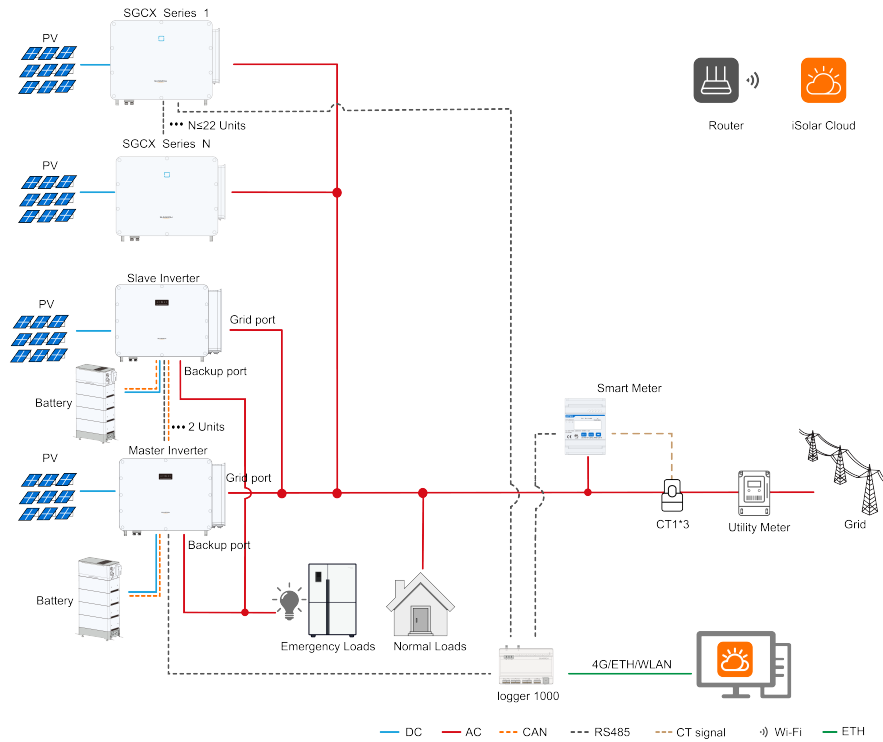

Figure 3-4 Grid Port Retrofit (Sungrow PV Inverter)

Component	Model/Type	Quantity	Remarks
Hybrid inverter	SH110CX/ SH125CX	2	<ul style="list-style-type: none"> <li>Key component of the energy storage system.</li> <li>Paralleled hybrid inverters must be of the same model.</li> </ul>
PV inverter	<ul style="list-style-type: none"> <li>Sungrow: SG50CX/ SG110X/ SG50CX-P2/ SG110CX-P2/ SG125CX-P2</li> <li>Third-party PV inverter</li> </ul>	≤22	Sungrow PV inverters and third-party PV inverters must not be mixed in the same system
Smart meter <sup>(1)</sup>	Refer to <a href="#">4.2.7 Meter Management</a>	1	Refer to <a href="#">4.2.7 Meter Management</a> .

Component	Model/Type	Quantity	Remarks
Current transformer (CT1)	Determined by grid connection point current	3	<ul style="list-style-type: none"> <li>CT compatible with Smart meter is required.</li> <li>CT specifications shall be determined based on grid connection point current.</li> </ul>
Current transformer (CT2)	Determined by grid connection point current	3	<ul style="list-style-type: none"> <li>Required only when connecting third-party PV inverters, the specifications of CT1 and CT2 shall be consistent and selected based on the grid connection point current.</li> <li>CT compatible with Smart meter is required.</li> </ul>
Communication device	Logger1000 (COM100)	1	/
Terminal resistor	120 Ω	2	<ul style="list-style-type: none"> <li>When the smart meter communication cable exceeds 10m, a 120Ω resistor must be connected in parallel at the meter terminals.</li> <li>When communication between the battery and the inverter, it is recommended to connect a 120Ω resistor in parallel at the CAN communication port of the battery farthest from the inverter.</li> </ul>
AC miniature circuit breaker (MCB): Grid port	320-400A/400V Type A (I <sub>max</sub> : 400A)	1 pcs for per hybrid inverter	<ul style="list-style-type: none"> <li>To be purchased by the customer. Select MCB with appropriate rated current based on actual needs, including wiring plan, number of loads, and inverter capacity.</li> </ul>
AC miniature circuit breaker (MCB): Backup port	250A/400V Type A (I <sub>max</sub> : 250A)	1 pcs for per hybrid inverter	<ul style="list-style-type: none"> <li>The circuit breaker must be installed on both the grid port and the backup port of the hybrid inverter.</li> </ul>
PV	/	/	Optional configuration; the hybrid inverter may operate without PV.

Component	Model/Type	Quantity	Remarks
Battery	Refer to <a href="#">4.2.6 Battery Management</a>	/	Battery connection is strongly recommended; to be purchased separately.

(1) When using third-party PV inverter, the dual-channel smart meter DTSU666-20 is required.

### 3.3.2.3.4.2 System settings



It is recommended to use the local access of Logger1000 for system commissioning. For Logger1000 login, network configuration, plant creation, device addition, etc., please refer to [Logger1000 User Manual](#).

The corresponding sections in [Logger1000 User Manual](#) for parameter setting operations are listed in the table below:

No.	Parameter setting	Reference section title
1	Enable Master-slave operating mode and set master-slave parameters	Configuring Parameters for Inverters
2	Set energy management mode	Select Energy Management Operating Mode
3	Enable Feed-in power limit: Total active power control or Per-phase active power control	
4	Set Feed-in power limit parameters	Grid-Connected Power Control
5	For third-party retrofit systems, set Third-party power generation system	
6	Set Purchase energy with limited power	
7	Enable Off-grid mode	System Power Backup
8	Set Backup SOC for off-grid operation	
9	Set CT transformation ratio	<ul style="list-style-type: none"> <li>Add meter: Adding a Meter</li> <li>Setting CT transformation ratio: Configuring Parameters for Meter</li> </ul>

### 3.3.3 Pure Off-grid System Scenario

#### 3.3.3.1 System Overview

A pure off-grid system is not connected to the utility grid and does not connect to a generator. All loads must be connected to the **BACKUP** port of the hybrid inverter. This configuration is mainly used for all backup ports one load scenarios.

Pure off-grid system: All loads are connected to the **BACKUP** port. The system is not connected to the utility grid and operates only in off-grid mode.



For details regarding the inverter's load carrying capacity, please contact SUNGROW.

Single-inverter/Multi-inverter System configuration						
Scenario	PV modules	Battery	Smart meter	Logger 1000	Manual change over switch	Grid
Pure off-grid system	●	●	✘	●	✘	✘

● Required, ✘ Not required

#### 3.3.3.2 Single-inverter System

##### 3.3.3.2.1 System Configuration

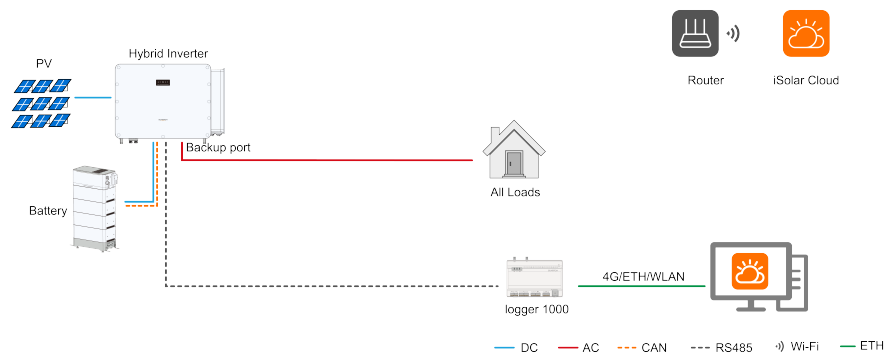

Component	Model/Type	Quantity	Remarks
Hybrid inverter	SH110/125CX	1	Key component of the energy storage system.

Component	Model/Type	Quantity	Remarks
Communication device	Logger1000 (COM100)	1	/
Terminal resistor	120 Ω	1	When communication distance between the battery and the inverter, it is recommended to connect a 120Ω resistor in parallel at the CAN communication port of the battery farthest from the inverter.
AC miniature circuit breaker (MCB): Backup port	250A/ 400V, Type A (I <sub>max</sub> : 250A)	1 pcs for per inverter	<ul style="list-style-type: none"> <li>To be purchased by the customer. Select MCB with appropriate specifications based on actual needs, including wiring plan, number of loads, and inverter capacity.</li> <li>The circuit breaker must be installed on the grid port of each hybrid inverter.</li> </ul>
PV	/	/	Must be configured and prepared by the customer
Battery	Refer to <a href="#">4.2.6 Battery Management</a>	/	The battery must be connected and purchased separately.

### 3.3.3.2.2 System Settings



It is recommended to use the local access of Logger1000 for system commissioning. For Logger1000 login, network configuration, plant creation, device addition, etc., please refer to [Logger1000 User Manual](#).

The corresponding sections in [Logger1000 User Manual](#) for parameter setting operations are listed in the table below:

No.	Parameter setting	Reference section title
1	Enable Off-grid mode	System Power Backup
2	Enable Off-grid emergency charging and set Target SOC of off-grid emergency charging	Configuring Parameters for Inverters

### 3.3.3.3 Multi-inverter System

#### 3.3.3.3.1 System Configuration

The backup ports of two hybrid inverters of the same model can be connected in parallel.

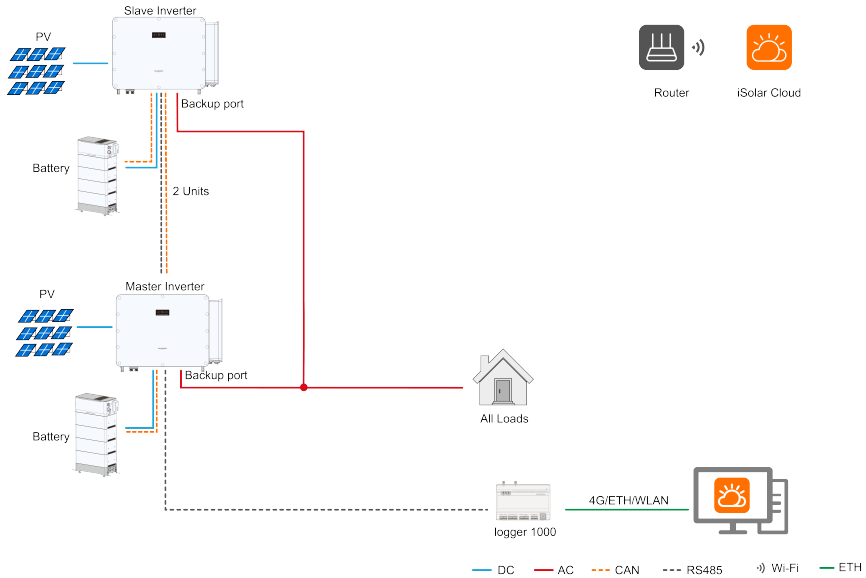

Component	Model/Type	Quantity	Remarks
Hybrid inverter	SH110/125CX	2	<ul style="list-style-type: none"> <li>Key component of the energy storage system.</li> <li>Paralleled hybrid inverters must be of the same model.</li> </ul>
Communication device	Logger1000 (COM100)	1	/
Terminal resistor	120 Ω	1	When communication distance between the battery and the inverter, it is recommended to connect a 120Ω resistor in parallel at the CAN communication port of the battery farthest from the inverter.
AC miniature circuit breaker (MCB): Backup port	250A/ 400V, Type A (I <sub>max</sub> : 250A)	1 pcs for per inverter	<ul style="list-style-type: none"> <li>To be purchased by the customer. Select MCB with appropriate specifications based on actual needs, including wiring plan, number of loads, and inverter capacity.</li> </ul>

Component	Model/Type	Quantity	Remarks
			<ul style="list-style-type: none"> <li>The circuit breaker must be installed on the grid port of each hybrid inverter.</li> </ul>
PV	/	/	Must be configured and prepared by the customer
Battery	Refer to <a href="#">4.2.6 Battery Management</a>	/	The battery must be connected and purchased separately.

### 3.3.3.3.2 System Settings



It is recommended to use the local access of Logger1000 for system commissioning. For Logger1000 login, network configuration, plant creation, device addition, etc., please refer to [Logger1000 User Manual](#).

The corresponding sections in [Logger1000 User Manual](#) for parameter setting operations are listed in the table below:

No.	Parameter setting	Reference section title
1	Enable Master-slave operating mode and set master-slave parameters	Configuring Parameters for Inverters
2	Enable Off-grid mode	System Power Backup
3	Enable Off-grid emergency charging and set Target SOC of off-grid emergency charging	Configuring Parameters for Inverters

### 3.3.4 Third-party Dispatching

In some countries, grid companies need to manage available energy to meet continuously changing supply and demand requirements and to maintain grid stability. Therefore, they need to communicate with hybrid inverters for external dispatch, such as frequency control or charge/discharge control.

- Third-party dispatching can be implemented when the system is operating in on-grid mode. Please contact Sungrow to obtain the API interface and access authorization, and complete interface debugging with the local company to ensure that performance and functions meet requirements. Control commands can then be transmitted via the iSolarCloud API service.
- If third-party IoT devices are used, Modbus protocol debugging shall be completed first.

## 4 Function Description

### 4.1 Safety Function

#### 4.1.1 Protection

The inverter integrates a variety of protection features, including short circuit protection, ground insulation resistance monitoring, residual current protection, anti-islanding protection, DC overvoltage, DC overcurrent protection, etc.

#### 4.1.2 Grounding Fault Alarm

The inverter has integrated a multiple-function dry-contact (DO relay), which can be used for the external alarm for earth fault. The external alarm needs to be powered by the grid. The additional equipment required is a light indicator. If an earth fault occurs:

- The DO dry contact will automatically activate and send a grounding fault alarm signal.
- The grounding fault alarm signal will be uploaded.

### 4.2 Energy Conversion and Management

The inverter converts DC power from PV arrays or batteries to AC power per grid requirements, and transfers DC power from PV panels to batteries.

With its integrated bidirectional converter, the inverter can charge/discharge batteries.

Multiple MPPT trackers maximize power output from PV strings with different orientations, tilt angles or module configurations.

#### 4.2.1 Power Derating

Power derating protects the inverter from overload or potential faults. Power derating is activated based on grid requirements.

#### 4.2.2 Normal Operating Voltage Range

The inverter can operate within the permitted voltage range for at least the specified observation time. Settings depend on the type of grid connection, such as normal startup or automatic reconnection after going off-grid.

If the voltage exceeds the operating or protection threshold, the inverter will disconnect from the grid within the specified time. If the disturbance duration exceeds the protective trip time, the inverter will automatically reconnect when voltage returns to normal.

### 4.2.3 Normal Operating Frequency Range

The inverter can operate continuously within its frequency range for at least the specified observation time. Settings depend on the type of grid connection, such as normal startup or automatic reconnection after going off-grid.

When frequency exceeds operating and protection thresholds, the inverter will disconnect from the grid. If the disturbance duration exceeds the protective trip time, the inverter will automatically reconnect after the frequency returns to a normal level.

### 4.2.4 Reactive Power Regulation

The inverter is capable of operating in reactive power regulation mode to support the grid. The reactive power regulation mode can be configured via the iSolarCloud App.

### 4.2.5 Load Control

The inverter integrates a multifunctional dry contact (DO relay) for load control via contactors. Control modes are user-configurable:

### 4.2.6 Battery Management

The currently supported battery brands and models are shown in the following table.

Inverter Model	Battery	
	Brand	Model
SH110CX		ST050CF / ST100CF / ST150CF / ST200CF / ST250CF
SH125CX	SUNGROW	ST050CF / ST062CF / ST075CF / ST087CF / ST100CF / ST112CF / ST125CF / ST137CF / ST150CF / ST162CF / ST175CF / ST187CF / ST200CF / ST212CF / ST225CF / ST237CF / ST250CF



- The table is continually updated. If the battery model is not in the table, consult SUNGROW if it is supported.
- When the connected battery capacity is less than 100 kWh, the system must be configured with PV.

### 4.2.7 Meter Management

The currently supported meter brands and models are shown in the following table.

Inverter Model	Meter	
	Brand	Model
SH110CX/ SH125CX	SUNGROW	DTSU666-20
	Weidmuller	EM610
	Acrel	DTSD1352
	Janitza	UMG604
	SUNGROW	DTSU666
	Jiangsu SFERE	PD194E/Z
	Acrel	PZ96-E3
	Schneider	IEM3255
	Janitza	UMG104



- The table is continually updated. If the meter model is not in the table, consult SUNGROW if it is supported.
- For details on using the meter, refer to section "Connecting to the Energy Meter" in the [Logger1000 User Manual](#).

### 4.3 Communication and Configuration

The inverter has various ports for device and system monitoring, including RS485, Bluetooth and CAN. Configure parameters for optimal performance. Inverter information can be accessed via the iSolarCloud App.

# 5 Unpacking and Storage

## 5.1 Unpacking and Inspection

The product has undergone strict tests and inspections before delivery. However, as it may still get damaged during transportation, please carry out a thorough inspection before signing the delivery receipt.

- Inspect the packaging for any damages.
- Check the delivered items for quantity and see if the delivery matches the order placed according to the packing list.
- Unpack and inspect the items inside for any damages.

Contact the transport company or SUNGROW in case of any damages or missing items, and provide relevant photos or the name/quantity of the missing items for better services.

Do not throw away the original packaging box. It is recommended to store the device in its original packaging after it is decommissioned.

### NOTICE

- **Inspect the product for any external damages or damages to the structural parts, and check if the packing list matches the order placed. In case of any problem with the above-mentioned inspection items, do not install the device and contact SUNGROW in time.**
- **If any tool is used for unpacking, be careful not to damage the product.**

## 5.2 Scope of Delivery

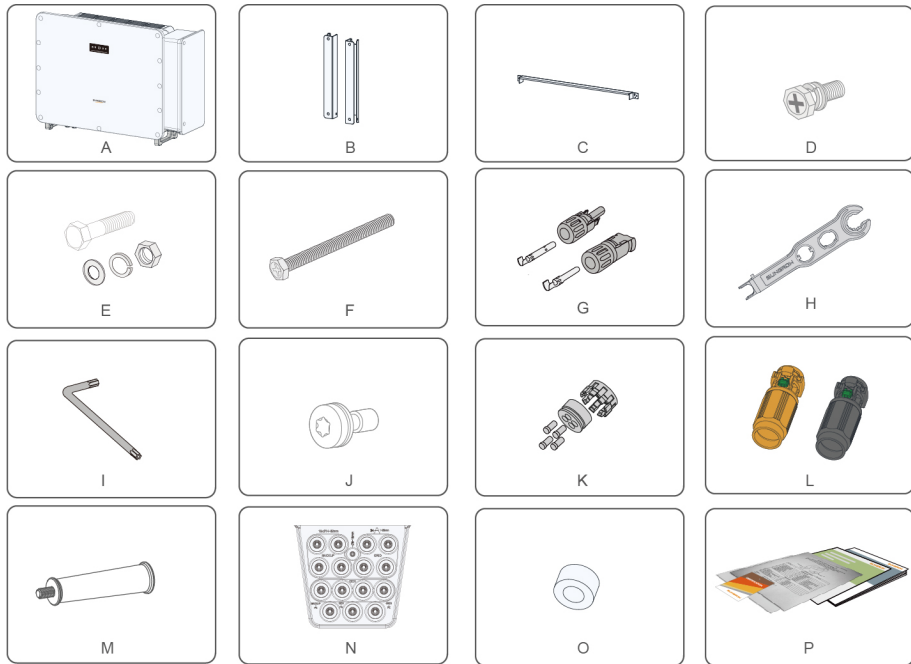

No.	Item	Quantity
A	Inverter	1
B	Mounting bracket	1
C	Bracket connecting plate	1
D	M4 × 10 screw	4
E	M10 screw	4
F	M6×65 screw	2
G	PV connector	20
H	PV terminal assembly/ disassembly tool	1
I	L-shaped wrench	1
J	M6×20 screw	1
K	4-hole waterproof seal	2
L	Battery Connector	1
M	Carrying handle	3

No.	Item	Quantity
N	Cable entry plate	1
O	Magnetic ring	2
P	Document	1



The figure shown here is for illustration only and the real product may differ.

### 5.3 Inverter Storage

Proper storage is required if the inverter is not installed immediately.

- Store the inverter in the original packing case with the desiccant inside.
- The storage temperature must be always between  $-40^{\circ}\text{C}$  and  $+70^{\circ}\text{C}$ , and the storage relative humidity must be always between 0 and 95 %, non-condensing.
- In case of stacking storage, the number of stacking layers should never exceed the limit marked on the outer side of the packing case.
- The packing case should be upright.
- If the inverter needs to be transported again, pack it strictly before loading and transporting it.
- Do not store the inverter in places susceptible to direct sunlight, rain, and strong electric field.
- Do not place the inverter in places with items that may affect or damage the inverter.
- Store the inverter in a clean and dry place to prevent dust and water vapor from eroding.
- Do not store the inverter in places with corrosive substances or susceptible to rodents and insects.
- Carry out periodic inspections. Inspection shall be conducted at least once every six months. If any insect or rodent bites are found, replace the packaging materials in time.
- If the inverter has been stored for one year or longer, or has been mounted but remains non-operational for more than three months, it must be inspected and tested by qualified personnel before being put into operation.

#### NOTICE

**Please store the inverter according to the storage requirements. Product damage caused by failure to meet the storage requirements is not covered by the warranty.**

## 6 Mechanical Mounting

### WARNING

Respect all local standards and requirements during mechanical installation.

### 6.1 Installation Precautions

#### DANGER

Make sure there is no electrical connection before installation.

#### WARNING

Poor installation environment will affect system performance. Refer to [6.2.1 Installation Environment Requirements](#) for detailed environmental requirements. SUNGROW shall not be held liable for any property damage caused by non-compliant installation environments.

#### CAUTION

Improper installation may cause personal injury!

- When moving the inverter, be aware of its weight and keep the balance to prevent it from tilting or falling.
- Wear proper protective equipment before performing operations on the inverter.
- The bottom terminals and interfaces of the inverter cannot directly contact the ground or other supports. The inverter cannot be directly placed on the ground.

#### NOTICE

Ensure that no device in the system causes it hard to disconnect the DC switch and the AC circuit breaker during the installation.

If drilling is required during installation:

- Wear goggles and safety gloves.
- Avoid the water pipes and electrical wires inside the wall when drilling.
- Cover the product to protect it from ingress of debris and dust.

### 6.2 Installation Site Selection

A good location is critical to the safe operation, long service life, and good performance of the inverter

- The inverter has an IP66 protection rating and can be installed indoors or outdoors.
- The installation height of the inverter should allow for clear visibility of the LED indicator panel and facilitate electrical connections, operation, and maintenance.

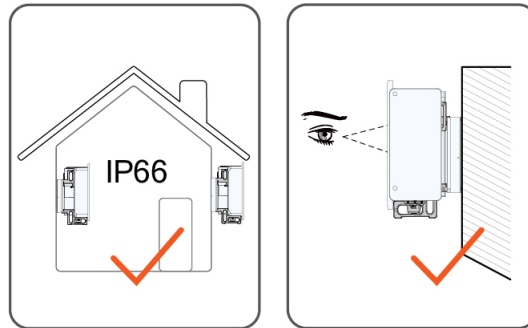

### 6.2.1 Installation Environment Requirements

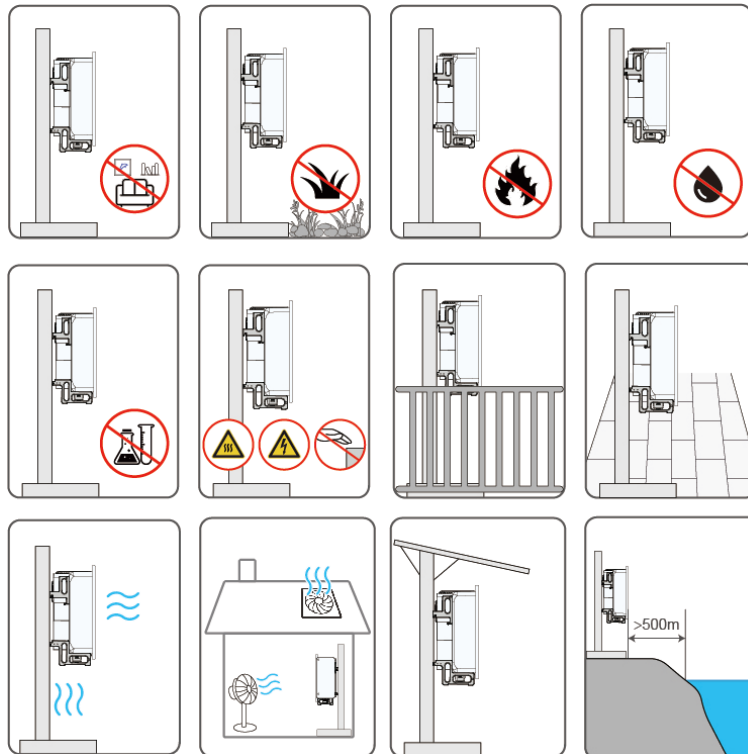

- The inverter produces noise during operation, thus it is not recommended to install it in places for residential purposes. If this cannot be avoided, it is recommended to install the inverter in a place over 25 meters away from the residential area, or take noise mitigation measures.
- If the inverter is installed in a place with lush vegetation, weed on a regular basis. In addition, the ground beneath the inverter needs to undergo certain treatment, such as laying cement or gravel, etc. (an area of 3 m × 2.5 m is recommended).
- Do not install the inverter in an environment with flammables, explosives, or smoke.

- Do not install the inverter in places prone to water leak, e.g., under the air-conditioner vent, the air vent, or the cable outlet window of the machine room, so as to prevent device damage or short circuit caused by intrusion of water.
- Do not install the inverter in a place with corrosives such as corrosive gas and organic solvent, etc.
- When the inverter is running, its surface may carry high voltages or get very hot. Do not touch it; otherwise, it may lead to burns or electric shocks.
- Do not install the inverter in a place that can be easily reached.
- The installation site must have solid ground, free of rubber-like soils (which cannot be effectively compacted) or weak soils, and should not be prone to subsidence. Also, avoid low-lying areas where water or snow may accumulate. Ensure the site is located above the highest recorded water level in the area.
- Do not install the inverter in a position that could be flooded.
- To prevent vegetation or water on the ground from impacting inverter operation, if the space above meets the designated requirements, elevate the inverter to an appropriate height.
- Install the inverter in a place with shelter, so as to prevent it from getting impacted by direct sunlight and severe weather (e.g., snow, rain, and lightning). The inverter will derate in high temperatures for self-protection. If installed in a place directly exposed to sunlight, as the temperature rises, the inverter may experience power reduction.
- Good heat dissipation is very important to the inverter. Please install the inverter in a ventilated environment.
- If the inverter needs to be installed in a closed or semi-closed environment, please install additional heat dissipation or ventilation devices. Furthermore, while the inverter is operating, ensure the indoor ambient temperature does not exceed the outdoor ambient temperature. A semi-closed environment refers to a special space where natural ventilation is limited and gas or heat may easily accumulate, although it is not fully enclosed on all six sides.
- Please consult SUNGROW before installing inverters outdoors in areas prone to salt damage, which are mainly coastal areas within 500 meters of the coast. The sedimentation amount of salt spray is correlated to the characteristics of the seawater, sea winds, precipitation, air humidity, topography, and forest coverage in the adjacent sea areas, and there are substantial differences between different coastal areas.
- To ensure device safety and service life, avoid using this product in highly polluted environments containing substances such as sulfur or halogens.
- The inverter is strictly prohibited from being installed in environments with vibration or strong electromagnetic fields (including strong common-mode interference). A strong magnetic field environment refers to one where the magnetic field strength exceeds 30 A/m. The aforementioned environments may cause the product to malfunction.
- In dusty environments such as places full of dust, smoke, dense intake/exhaust grilles or floc, particles may cling to the device's air outlet or heat sink, thus impacting its heat dissipation performance or even getting it damaged. Therefore, do not install the inverter in dusty environments. If the inverter has to be installed in such environments,

please clean its fans and heat sink on a regular basis to ensure a good heat dissipation performance.

- The average temperature approximately 1 m around the inverter should be taken as its ambient operating temperature. The temperature and humidity should meet the requirements below:

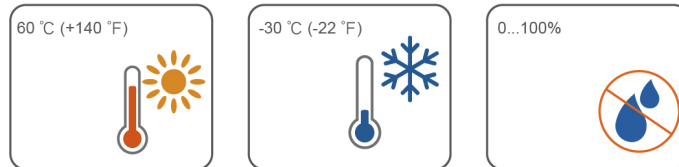

- For installed inverters that remain non-operational for an extended period, follow these requirements:
  - Seal all unused DC terminals with the plugs supplied with the inverter.
  - If the inverter is installed in a dusty or sandy environment, add protective covers at the air inlet and outlet to prevent dust accumulation that could obstruct airflow and affect fan operation. Remove the protective covers before putting the inverter into service.

#### NOTICE

- **If the inverter is installed indoors or if there are significant obstructions in the air outlet pathway, add ventilation equipment to enhance heat dissipation. The temperature at the air inlet of the inverter must not exceed the nominal ambient temperature specified for operation at rated power under the current working conditions to ensure long-term stable system operation.**
- **Ensure a ventilation rate of  $\geq 1000 \text{ m}^3/\text{h}$  and a cooling capacity of  $\geq 5 \text{ kW}$  at the rear air outlet of each inverter.**

### 6.2.2 Installation Support Requirements

The installation surface must have a load-bearing capacity of at least 4 times the inverter's weight and match the inverter dimensions.

Do not install the inverter on surfaces prone to resonance, as this may cause excessive noise.

Installation on combustible building materials is strictly prohibited. Suitable mounting surfaces include: Non-combustible wall surfaces: Concrete, fire-resistant gypsum board, brick wall, etc. Non-combustible roof structures: Color-Coated corrugated steel roofing sheets, precast concrete slabs, fiber-reinforced cement boards, etc.



### 6.2.3 Installation Angle

It is recommended that the inverter be installed vertically or tilted backward. Forward or upside-down installation and installation at a left tilt, right tilt, or excessive back tilt are not allowed.

Backward installation does not apply to floating power plants.

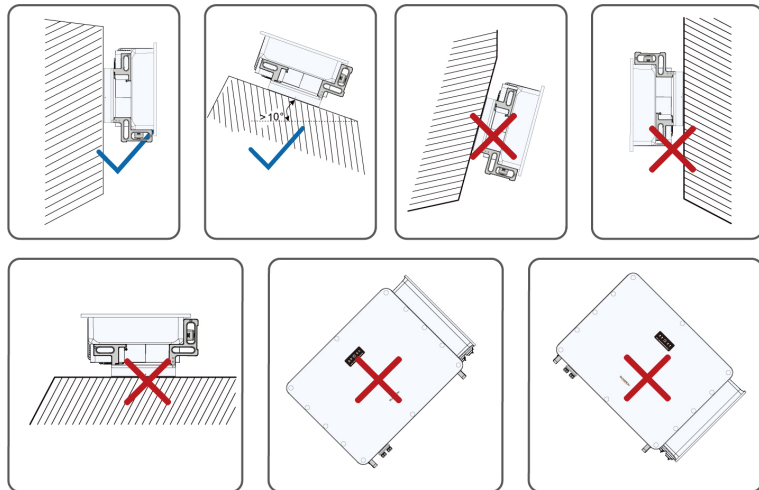

#### Backward Installation Requirements

To install the inverter on level ground, add a rack under it to ensure the installation angle meets the specified requirements. The figure below presents an inverter mounted on a rack.

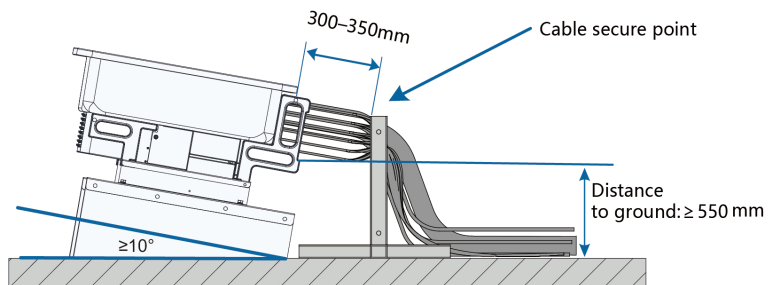

Take into account the below requirements when designing a racking system for the inverter:

- Consider the climatic conditions at the site. Take protective measures against rain and snow if necessary.
- The waterproof connectors should be  $\geq 550$  mm off the ground.
- Secure the cables with cable ties at a distance of 300–350 mm from the DC connectors and the waterproof connectors for communication terminals. This prevents the connectors from loosening due to stress caused by cable hanging down or swaying, hence avoiding impairing the ingress protection performance of the inverter.
- Tighten the waterproof connectors at the torques specified in this manual. Ensure the connectors are secure and well-sealed.

In case of any questions, please contact SUNGROW.

### 6.2.4 Installation Space Requirements

#### Space Required for Installing One Single Inverter

Make sure there is sufficient space around the inverter for good ventilation. The space requirements for installing one inverter are shown in the figure below.

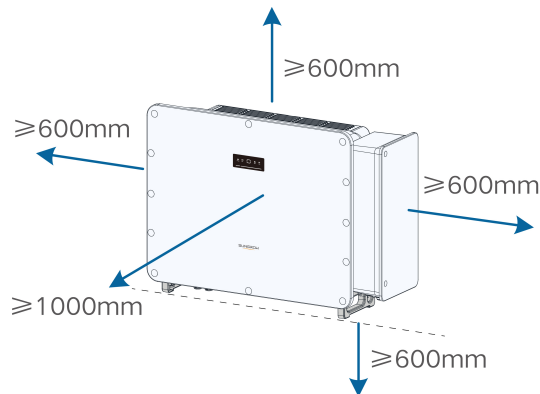

The minimum ground clearance for the inverter is 600 mm. The actual installation height may vary depending on cable specifications.

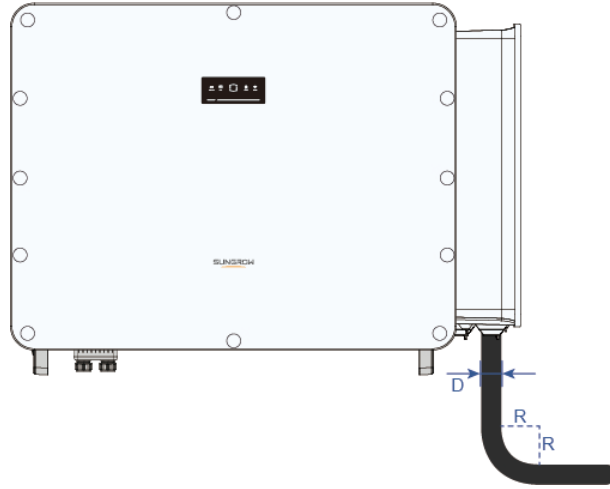

**Single-core wire**

**Multi-core wire**

Single-core wire		Multi-core wire	
Unarmored cable	Armored cable	Unarmored cable	Armored cable
$R \geq 20D$	$R \geq 15D$	$R \geq 15D$	$R \geq 12D$

**i** R is the bending radius, and D is the outer diameter of the thickest connected cable. AC cables must enter the maintenance chamber vertically.

**i** If the actual space reserved for the inverter is smaller than that required in the figure, before maintaining its fans, lift the inverter away from the bracket or wall.

**Inverters Installed in One Row**

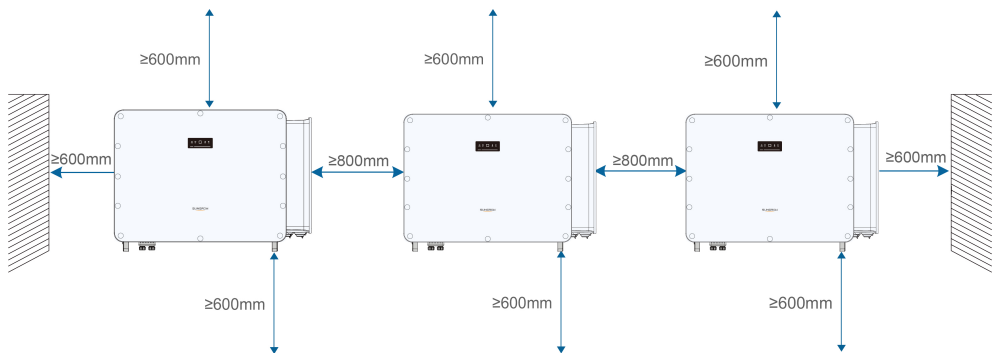

**Inverters Installed in an Inverted-T Pattern**

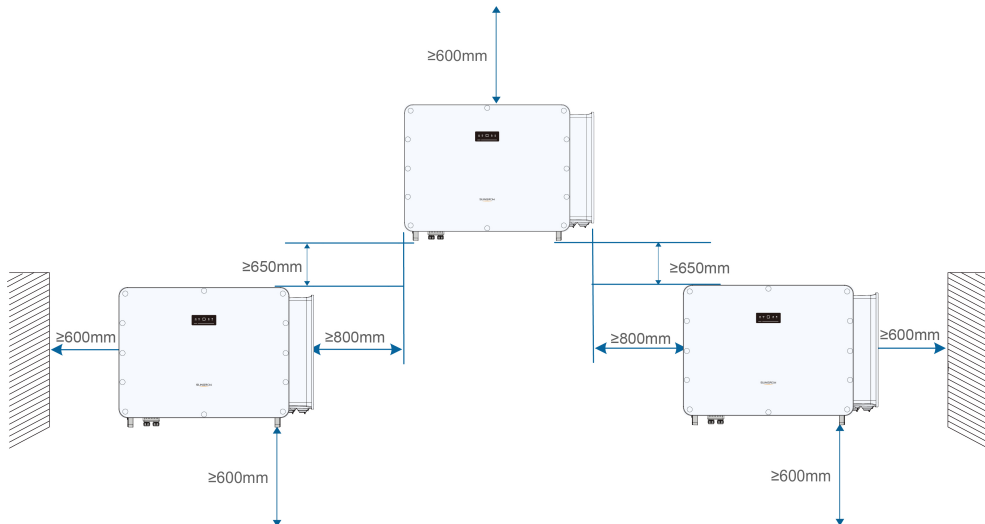

### Inverters Installed Back-to-back

For inverters installed back to back, the distance between them should be at least 600mm. In this scenario, a baffle should be added between the two inverters to make a channel for heat dissipation. The baffle should be placed horizontally between the two inverters, without blocking their air outlets.

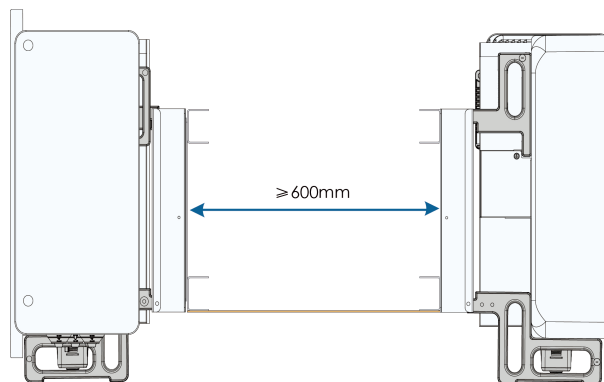

- In case the inverters need to be arranged in tiers with one above another, please refer to the "Installation Instructions for Commercial & Industrial Application Scenarios".
- To learn about the heat dissipation requirements for inverters installed indoors, please contact SUNGROW.

## 6.3 Installation Tools

Installation tools to be used include but are not limited to those listed below. If necessary, use other auxiliary tools at the site.



Goggles

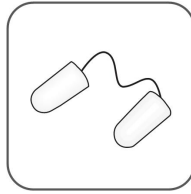

Earplugs

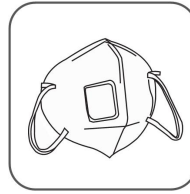

Dust mask



Safety gloves



Safety shoes



Utility knife

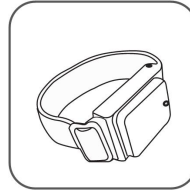

Anti-static wrist strap

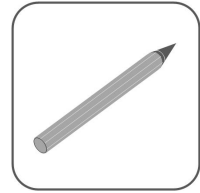

Marker

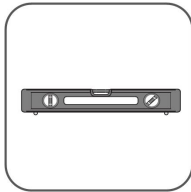

Level

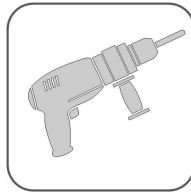

Hammer drill  
( $\phi 12$ )

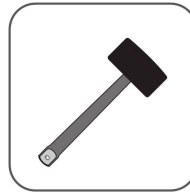

Rubber mallet



Phillips  
screwdriver (M4,  
M6, M8)

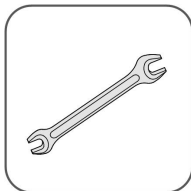

Open-end wrench  
(16mm, 33mm)



Socket wrench  
set (M4, M8, M12)

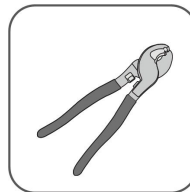

Wire cutter

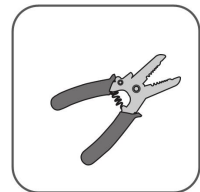

Wire strippers

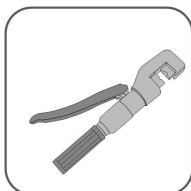

Hydraulic pliers

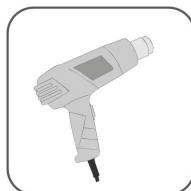

Heat gun



Slotted  
screwdriver (M2,  
M3, M6)

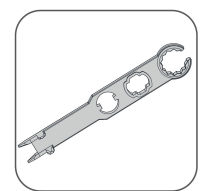

Connector wrench

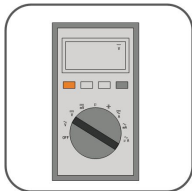

Multimeter ( $\geq 1100$   
V DC)



Vacuum cleaner



Scissors

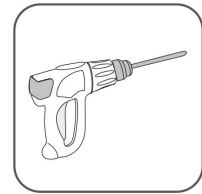

Electric drill ( $\phi 12$ )



Crimping tool (4–  
6 mm<sup>2</sup>)

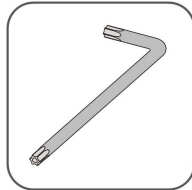

Allen wrench

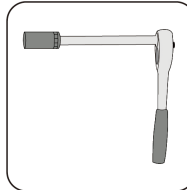

Socket (16mm)

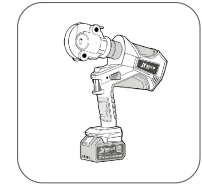

Li-ion hydraulic  
plier

## 6.4 Move Inverter

Before installation, take the inverter out of the packing crate and move it to the target position.

It is recommended to move the inverter using its top and bottom handles and the add-on handles. Grip the handles, lift the inverter, and move it to the target position.

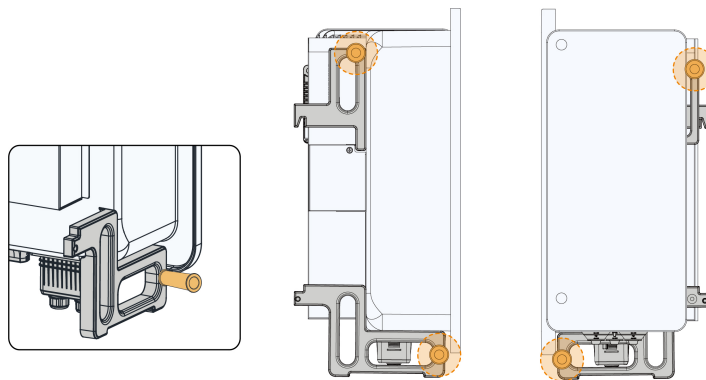

### Move an Inverter that Lays Flat

To take the inverter out of the crate, use mainly the vertical handles at the top and bottom of the inverter (as indicated in the figure below).

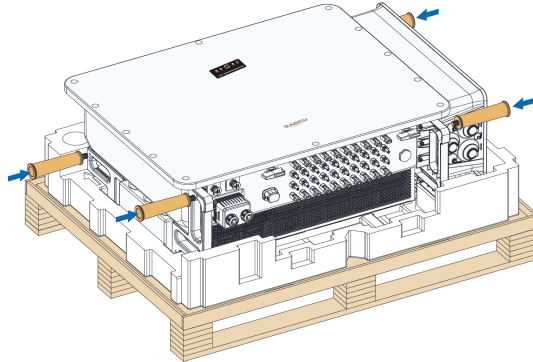

### Hang the Inverter to the Mounting bracket

To hang the inverter to the mounting bracket, use mainly the top vertical handles, the bottom-left horizontal handle, and the bottom-right add-on handle.

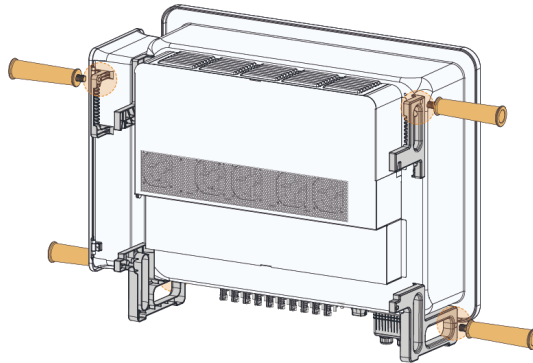

#### **⚠ CAUTION**

Improper handling may lead to personal injury!

- Properly decide the number of installation personnel to handle the inverter based on the inverter's weight. Installation personnel should wear protective equipment such as anti-impact shoes and safety gloves.
- Always pay attention to inverter's center of gravity during handling and prevent it from getting tilted.
- Putting the inverter directly on a hard ground may cause damage to its metal enclosure. Therefore, protective material such as foam or a sponge mat should be placed underneath the inverter.
- Move the inverter by holding its handles. Do not move it by gripping its connectors.

## 6.5 Install Mounting Bracket

Use a mounting bracket to mount the inverter on a wall or a PV bracket (PV module holder).

The dimensions of a mounting bracket assembly are shown below.

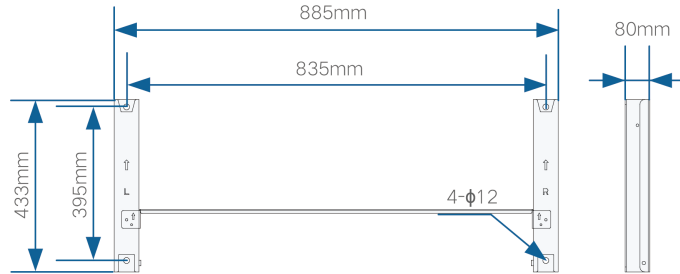

**Figure 6-1** Dimensions of Mounting Bracket

Reserve sufficient space when installing the mounting bracket. Make sure the space requirements for inverter installation are met.

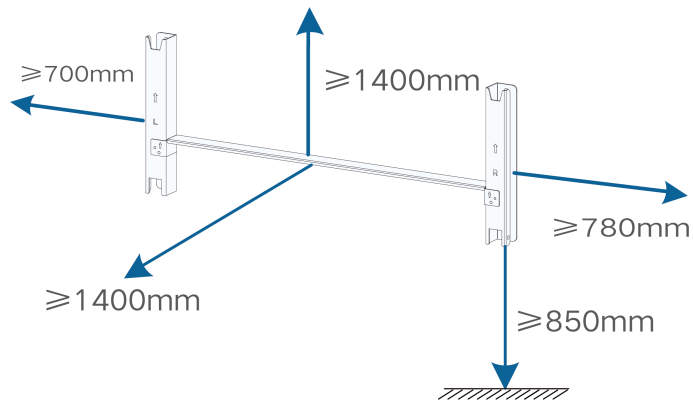

**Figure 6-2** Requirements of Space Reserved for Inverter Installation

### 6.5.1 Mounted on PV Bracket

#### Prerequisite

#### Tools

Item	Specification
Phillips screwdriver	M4
Marker	-
Level	-
Electric drill	Drill bit: $\phi 12$
Socket	16 mm

#### Required Materials

Item	Quantity	Specifications	Source
Phillips screwdriver	4	M4×10	Packing list
Bolt assembly	4	M10	Packing list

**Step 1** Assemble the mounting bracket together by fixing the two sub-brackets to the two sides of the connecting plate.

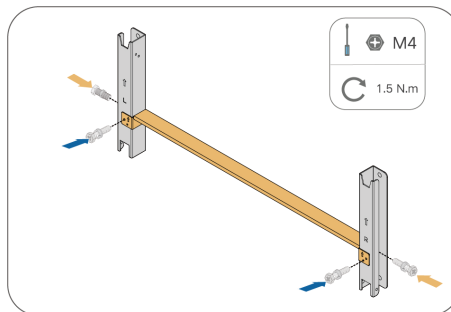

**Step 2** Put the mounting bracket assembly on the PV bracket, adjust its angle with the assistance of the level, and mark the hole positions for drilling. Then, drill holes at the corresponding positions using an electric drill.

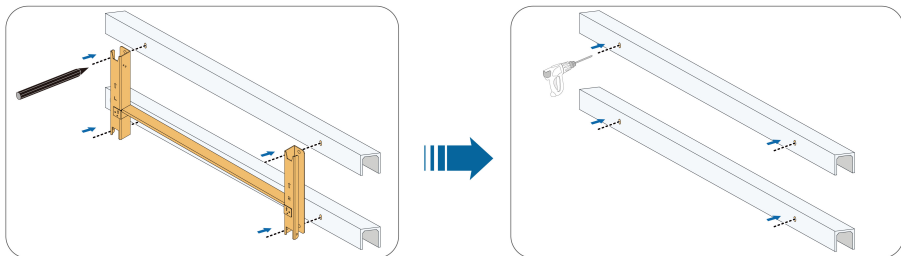

S322-I011

**Step 3** Secure the mounting bracket with bolts.

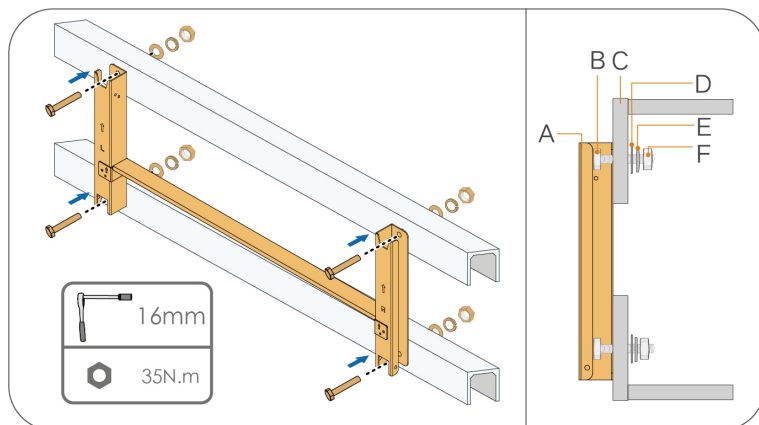

(A) Mounting bracket	(B) Fully- threaded bolt	(C) Metal bracket	(D) Flat washer	(E) Spring washer	(F) Hexagon nut
----------------------------	-----------------------------	----------------------	-----------------------	----------------------	-----------------------

--End

## 6.5.2 Mounted on Wall

### Prerequisite

### Tools

Item	Specification
Phillips screwdriver	M4
Marker	-
Level	-
Hammer drill	Drill bit: $\phi 12$
Socket	16 mm

### Required Materials

Item	Quantity	Specifications	Source
Phillips screwdriver	4	M4×10	Packing list
Expansion bolt	4	M10×95 (recommended)	Prepared by the user

**Step 1** Assemble the mounting bracket together by fixing the two sub-brackets to the two sides of the connecting plate.

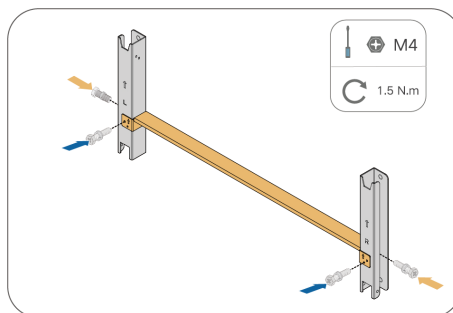

**Step 2** Put the mounting bracket assembly at the target position. Adjust its angle with the assistance of the level, and mark the hole positions for drilling.

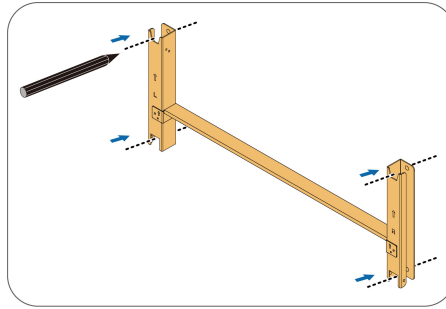

S322-I013

**i** For SH110CX, the hole-drilling template included in the delivery scope can be used to mark the hole positions for drilling. For details, please refer to [7.10 Install Protective Cover \(Optional for SH110CX\)](#).

**Step 3** Drill holes using a hammer drill, and clean the holes. Then, insert the expansion bolts into the holes, and tap the bolts using a rubber mallet to secure them in place. Next, tighten the nuts at the end of the bolts using a wrench to make the bolt sleeves expand. After that, remove the nuts, spring washers, and flat washers, and keep them properly for later use.

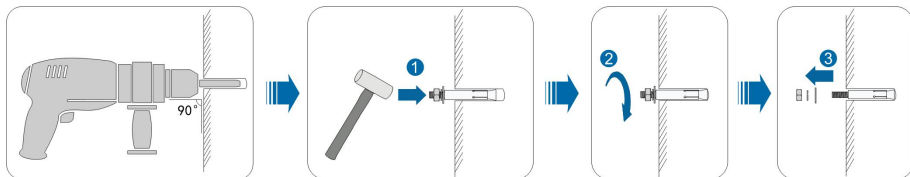

**i** After removing the nuts, spring washers, and flat washers, make sure the ends of expansion bolt sleeves are flush with the wall surface. Otherwise, the mounting bracket will not stay stable on the wall.

**Step 4** Hang the mounting bracket to the expansion bolts, and fit the washers and nuts to fix it.

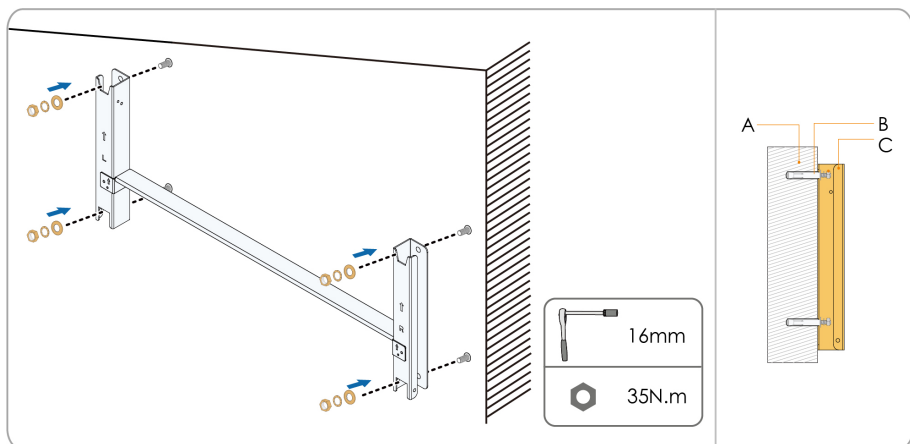

(A) Wall                      (B) Bolt assembly                      (C) Mounting bracket

--End

### 6.5.3 Mounted on Pole

#### Prerequisite

#### Tools

Item	Specification
Phillips screwdriver	M4
Marker	-
Level	-
Electric drill*	Drill bit: $\phi 12$
Socket	16 mm

\*Determine if tools with different specifications are required based on the size of the bolts used for the matching clamp.

#### Required Materials

Item	Quantity	Specifications	Source
Phillips screwdriver	4	M4×10	Packing list
Bolt assembly	4	M10	Packing list
Nut assembly	4	M10	Prepared by the user
Steel U-channel	2	-	Prepared by the user
Clamp	2	Decide according to the size of the pole.	Prepared by the user

**Step 1** Bury the pole to an appropriate depth in the ground at the installation site.



Skip this step if the inverter is pole-mounted on a cement pillar or PV bracket.

**Step 2** Assemble the mounting bracket together by fixing the two sub-brackets to the two sides of the connecting plate.

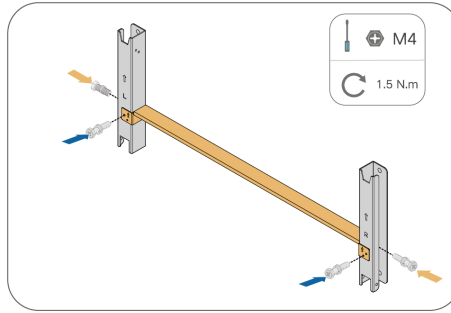

**Step 3** Mark the hole positions on the U-channels by referring to the instructions in the figure below, and drill holes.

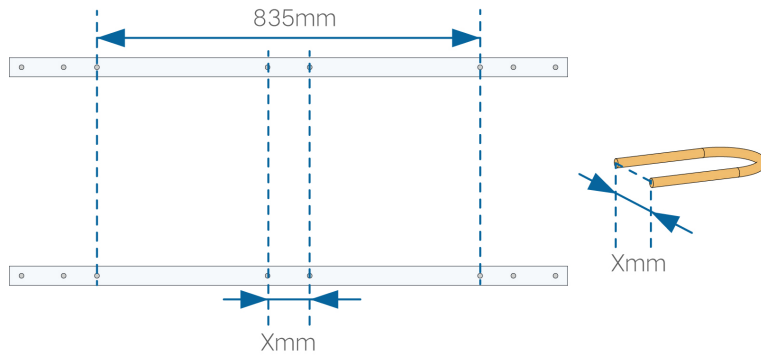

**Step 4** Fix the U-channels to the pole with bolts and clamps.

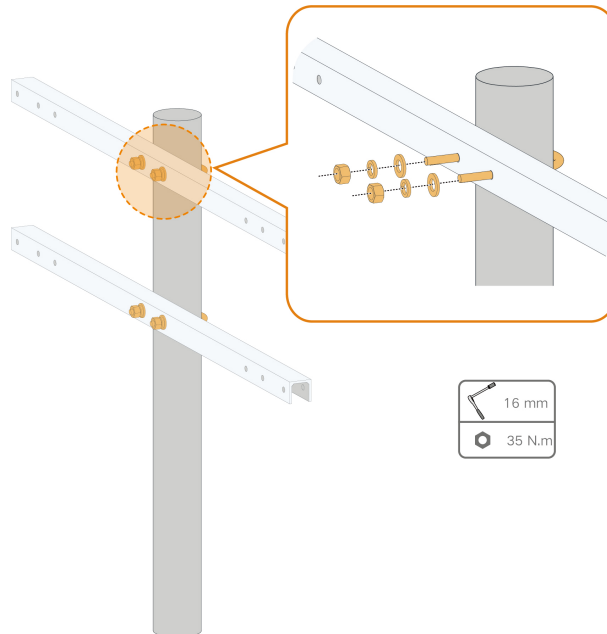

**Step 5** Fix the mounting bracket to the U-channels with bolts.

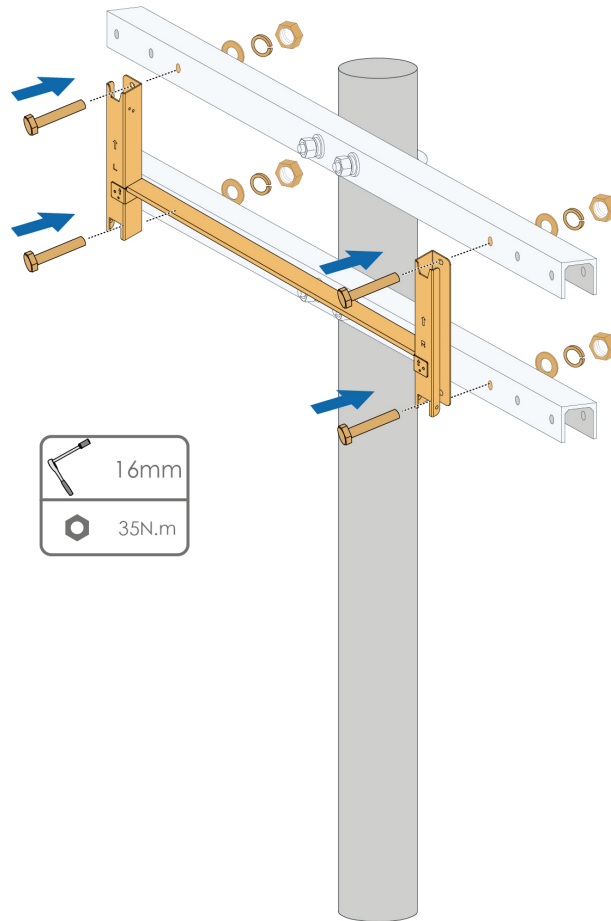

--End

## 6.6 Mount the Inverter

### Prerequisite

### Tools

Item	Specification
Phillips screwdriver	M6

### Required Materials

Item	Quantity	Specifications	Source
Phillips screwdriver	2	M6×65	Packing list

**Step 1** Take the inverter out of the packing crate.

**Step 2** Hang the inverter on the mounting bracket. Ensure the inverter's mounting ears fit perfectly into the mounting bracket.

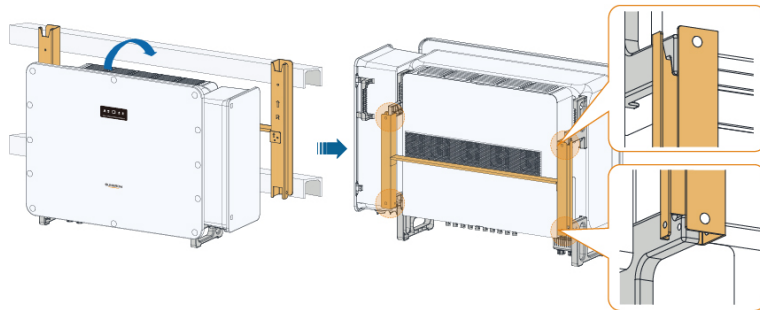

**Step 3** Fix the inverter with screws.

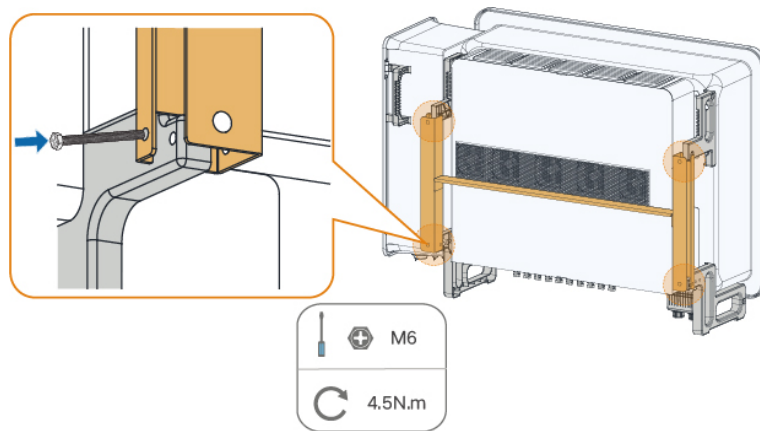

#### NOTICE

The inverter's left and right sides must be fixed to the mounting bracket with screws, otherwise, the inverter may not be secure.

--End

# 7 Electrical Connection

## 7.1 Installation Precautions

### DANGER

Hazardous voltages on the PV string when it is exposed to sunlight!

- Operators must wear proper personal protective equipment during electrical connections.
- Check and confirm that the DC cables are voltage-free using a measuring instrument before touching them.
- Observe all the safety instructions listed in the documents for the PV string and other relevant documents.

### DANGER

- Before electrical connections, please make sure that the inverter switch and all switches connected to the inverter are set to "OFF", otherwise electric shock may occur!
- Ensure that the inverter is undamaged and all cables are voltage free before performing electrical work.
- Do not close the AC circuit breaker until the electrical connection is complete.

### WARNING

- Do not damage the ground conductor. Do not operate the product in the absence of a properly installed ground conductor. Otherwise, it may cause personal injury or product damage.
- Please use measuring devices with an appropriate range. Overvoltage can damage the measuring device and cause personal injury.

### WARNING

Damage to the product caused by incorrect wiring is not covered by the warranty.

- Electrical connections must be performed by qualified personnel.
- Operators must wear proper personal protective equipment during electrical connections.
- All cables used in the PV generation system must be firmly attached, properly insulated, and adequately dimensioned.
- The factors that affect cable selection include rated current, cable type, routing mode, ambient temperature, and maximum expected line loss.

**NOTICE**

All electrical connections must be done in compliance with the applicable local and national/regional electrical standards.

- Cables used shall comply with the requirements of local laws and regulations.
- Only with the permission of the national/regional grid department, the inverter can be connected to the grid.

**NOTICE**

- Install the external protective grounding cable first when performing the electrical connection and remove the external protective grounding cable last when removing the inverter.
- Keep the AC output cable and the DC input cable close to each other during the electrical connection.
- Wiring must be done in compliance with the applicable local grid regulations and relevant safety instructions specified for the PV string.

**NOTICE**

- After being crimped, the OT terminal must wrap the wires completely, and the wires must contact the OT terminal closely.
- When using a heat gun, protect the device from being scorched.
- Keep the PV+ cable and PV- cable close to each other when connecting DC input cables.
- Before connecting a power cable (such as the AC cable, the DC cable, etc.), confirm that the label and identifier on the power cable are correct.
- When laying out communication cables, separate them from power cables and keep them away from strong interference sources to prevent communication interruption.
- All vacant terminals must be covered with waterproof covers to prevent affecting the protection rating.
- Ensure that AC output cables are firmly connected. Failing to do so may cause inverter malfunction or damage to its AC connectors.
- When the wiring is completed, seal the gap of cable inlet and outlet holes with fireproof / waterproof materials such as fireproof mud to prevent foreign matter or moisture from entering and affecting the long-term normal operation of the inverter.



Incorrect cable connections may lead to inaccuracies in the power flow diagram. In such cases, it is necessary to verify the correctness of the wiring.



The wire colors in the figures in this manual are for reference only. Please select wires according to local cable codes.

## 7.2 Terminal Description

Terminals are located at its side and bottom, as shown in the figure below:

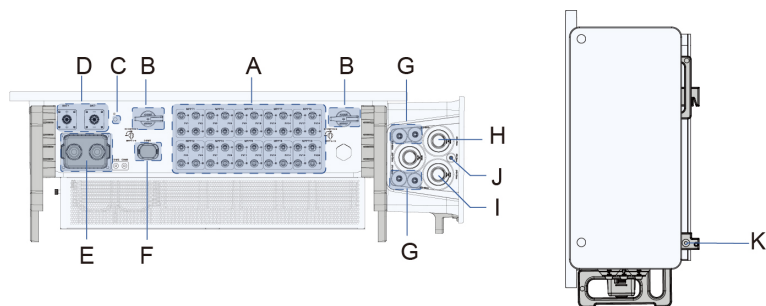

**Figure 7-1** Terminal Description

\*The figure is for reference only and the real product may differ.

No	Item	Label	Remarks
A	DC input terminals	+ / -	20 pairs, PV connector.
B	DC switch	DC SWITCH	Used to control the connection and disconnection of DC inputs.
C	Battery grounding terminals		Used for battery grounding.
D	Battery terminals	BAT+/BAT-	Used for battery connection.
E	Communication terminals	COM2/COM3	Used for communication with meter, battery, logger, DRM, DO, RSD.
F	Communication terminals	COM1	Used for connecting a communication module.
G	Grounding terminal	PE	Used for internal grounding.
H	Load AC terminals	BACKUP	Used for load AC connection.
I	Grid AC terminals	GRID	Used for grid AC connection.

No	Item	Label	Remarks
J	Battery auxiliary power terminals	BAT aux power	Used for auxiliary power output from the battery
K	External grounding terminals		Used for the reliable grounding of the inverter. Two grounding terminals are provided. Use at least one of them for grounding.

### 7.3 Electrical Connection Overview

To connect the inverter to the PV system, these electrical connections should be completed: external grounding, and connections of the grid and the PV strings.

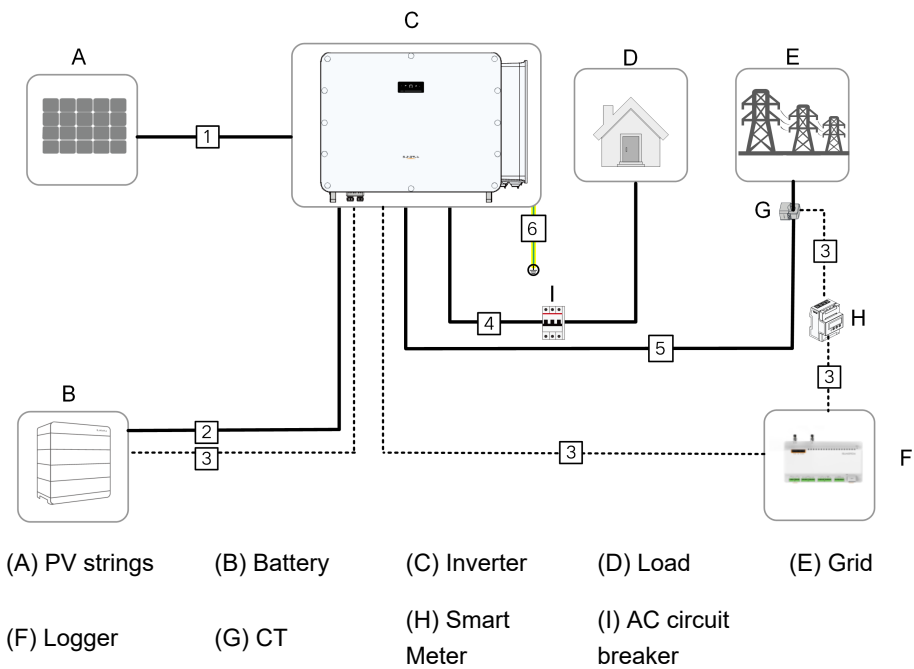

- For Australia, a DC circuit breaker must be installed between the battery and the inverter.
- The actual wiring between the battery and the logger is determined by the battery model. For detailed instructions, please consult the manual provided by the battery manufacturer.

**Table 7-1** Cable Requirements

No.	Item	Type	Specification	
			Outer Diameter (mm)	Cross-sectional area of conductor (mm <sup>2</sup> )
1	DC cable	PV cable, complying with 1,000V standard	5.9–8.8	4/6
2	Battery Cable	Copper Cable	15–24	70–95
3	Communication cable*	Shielded twisted pair		0.2–1.5
		CAT 5E outdoor shielded network cable**	4.5–18	8 × 0.2
4 5	AC cable (BACK UP/GRID)	Outdoor single-core copper/aluminum cable	14–32	120–300
		Outdoor multi-core copper/aluminum cable	L1, L2, L3, and N wire: 40–72 PE wire: 14–30	120–240
6	Additional Grounding cable	Outdoor single-core copper cable	S/2 S: Cross-sectional area of the phase wire.***	



- If local regulations have other requirements for AC cables and additional grounding cable, select cable specifications according to the local regulations.
- The factors that affect cable selection include rated current, cable type, routing mode, ambient temperature, and maximum expected line loss.
- The cabling distance between the battery and the inverter should be less than 40 m, and within 5 m is recommended.

\*Do not coil the communication cable.

\*\*To meet shielding and anti-interference requirements:

- Shielded Ethernet cables are mandatory. It is recommended to use CAT 5E or CAT 6 shielded cables.
- Use Ethernet cables with magnet cores at both ends, and in some cases, add magnet cores in the middle.



\*\*\*This rule applies only if the phase wires and the PE wire are identical in material. If the materials are different, make sure the cross-section of the PE wire allows it to produce a conductance equivalent to that resulting from the application of this table.

### Backup Wiring Diagram (Australia and New Zealand)

The neutral cable of GRID side and BACKUP side must be connected together according to the wiring rules AS/NZS\_3000. Otherwise the backup function will not work.

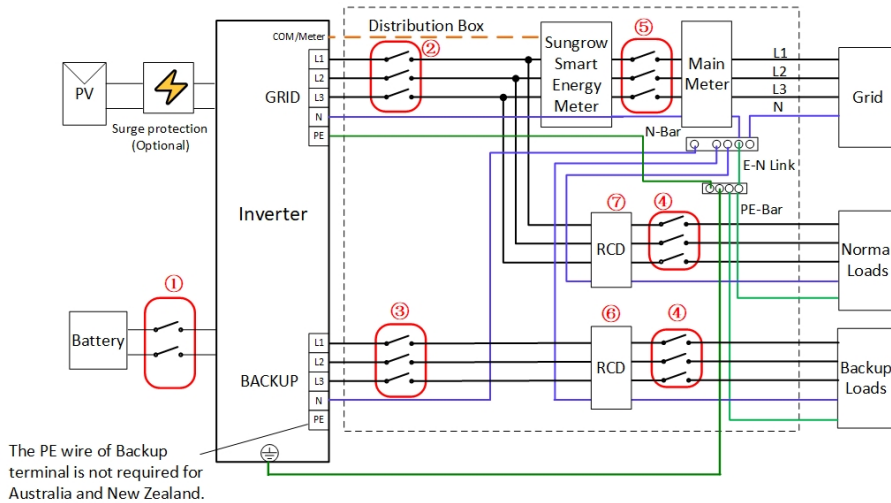

No.	SH110CX/SH125CX
①	250A/ 1000V DC Breaker*
②	320-400A/400V ** TypeA AC Circuit Breaker ( $I_{max}$ : 400A)
③	250A/ 400V TypeA AC Breaker( $I_{max}$ : 250A)
④	Depends on Load
⑤	Depends on loads and inverter capacity
⑥⑦	30 mA RCD (Comply with local regulations)

1. \*If the battery includes a user-operable DC circuit breaker, no additional DC breaker is required.

2. \*\* Select MCB with appropriate rated current based on actual needs, including wiring plan, number of loads, and inverter capacity.
3. Values in the table are recommended and can be adjusted as necessary.
4. To enhance system safety, set an "Input Power Limit" for the inverter immediately after wiring. Calculation formula: Input Power Limit (kW)  $\leq 3 \times 230 \times 0.8 \times$  rated current of the main switch.



The specifications of the AC breaker must be configured according to the recommendations in the user manual (do not exceed the recommended maximum current value). Otherwise, there is a risk of inverter failure.

### Whole Site Backup Wiring Diagram (Australia and New Zealand)

Whole Home Backup:

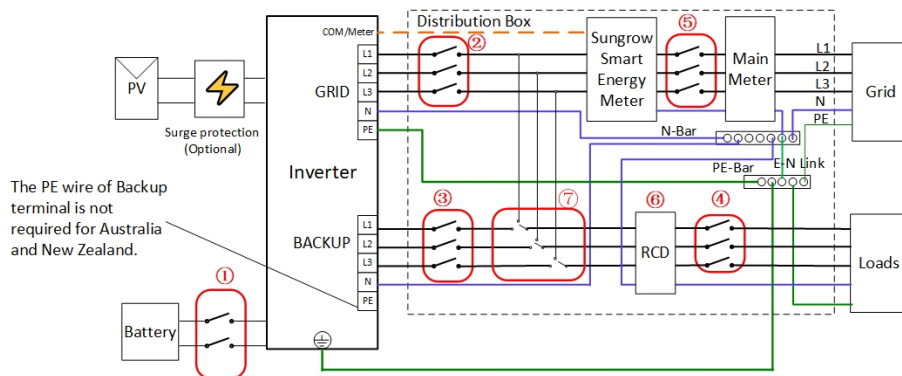

NO.	SH110CX/SH125CX
①	250A/1000V DC breaker
②	320~400A/400V TypeA AC breaker ( $I_{max}$ : 400A)
③	250A/ 400V TypeA AC Breaker ( $I_{max}$ : 250A)
④	Depends on Load
⑤	Depends on loads and inverter capacity
⑥	30mA RCD (Comply with local regulation)
⑦	320~400A/400V manual changeover switch*

\*The manual changeover switch is included in the scope of delivery. A 320~400A manual changeover switch is required for the whole site backup scenario. When switching to "BACKUP" using the changeover switch, loads will be supplied by the PV installation and battery. When the inverter is faulty or undergoing maintenance, switch to "GRID" to ensure the loads can work normally.

**i** The specifications of the AC breaker must be configured according to the recommendations in the user manual (do not exceed the recommended maximum current value). Otherwise, there is a risk of inverter failure.

**Backup Wiring Diagram (Other Countries)**

The following diagram is an example for grid systems without special requirement on wiring connection.

Loads Connected to the Grid:

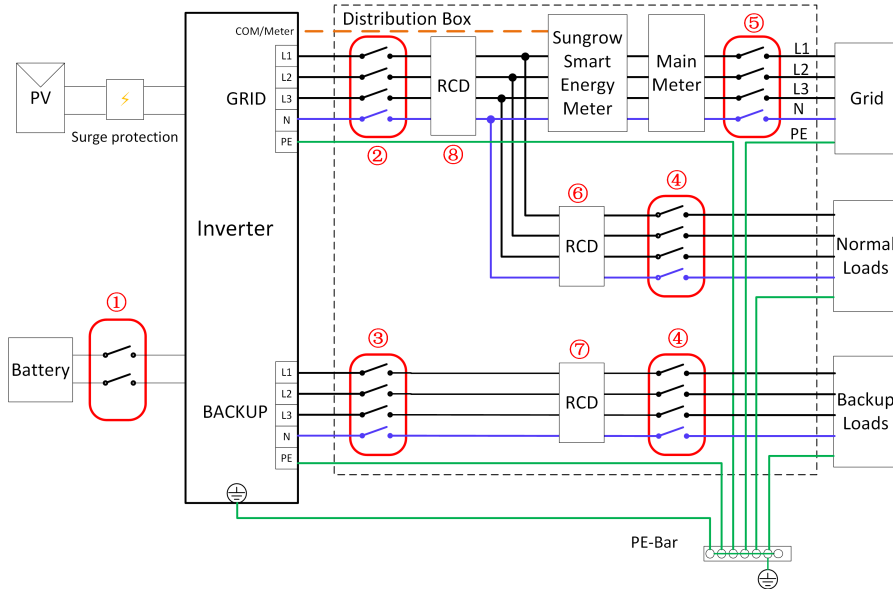

NO.	SH110CX/SH125CX
①	250A/1000V DC breaker *
②	320-400A/400V ** TypeA AC breaker ( $I_{max}$ : 400A)
③	250A/ 400V TypeA AC Breaker ( $I_{max}$ : 250A)
④	Depends on Load
⑤	Depends on loads and inverter capacity
⑥⑦	30mA RCD (Comply with local regulation)
⑧	SH125CX: 1250mA RCD (Comply with local regulation) SH110CX: 1100mA RCD (Comply with local regulation)

1. \*If the battery is integrated with a readily accessible internal DC breaker, no additional DC breaker is required.

2. \*\*Select an MCB with an appropriate rated current based on the actual requirements, including the overall wiring scheme, the number of loads, and the inverter's load-carrying capacity.

3. The values in the table are recommended values and can be set to other values according to actual conditions.

4. To improve the safety of the system, set the "Import Power Limit" for the inverter immediately after completing the wiring. The formula used to calculate the import power limit should be: Set value of Import Power Limit (kW)  $\leq 3 \times 230 \times 0.8 \times$  rated current of the main switch.



The specifications of the AC breaker must be configured according to the recommendations in the user manual (do not exceed the recommended maximum current value). Otherwise, there is a risk of inverter failure.

### Whole Site Backup Wiring Diagram (Other Countries)

Whole Home Backup:

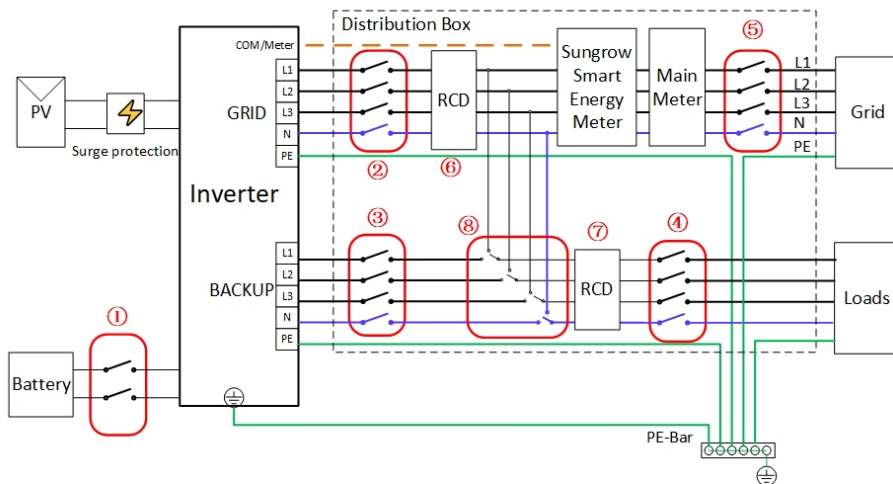

NO.	SH110CX/SH125CX
①	250A/1000V DC breaker
②	320~400A/400V TypeA AC breaker ( $I_{max}$ : 400A)
③	250A/ 400V TypeA AC Breaker ( $I_{max}$ : 250A)
④	Depends on loads
⑤	Depends on loads and inverter capacity
⑥	SH125CX: 1250mA RCD (Comply with local regulation) SH110CX: 1100mA RCD (Comply with local regulation)

NO.	SH110CX/SH125CX
⑦	30mA RCD (Comply with local regulation)
⑧	≥320~400A/400V manual changeover switch*

\*The manual changeover switch should be prepared by users separately. For the whole site backup scenario, it is recommended to use at least a 320A manual changeover switch, with 400A preferred. When switching to "BACKUP" using the changeover switch, loads will be supplied by the PV installation and battery. When the inverter is faulty or undergoing maintenance, switch to "GRID" to ensure the loads can work normally.

**i** The specifications of the AC breaker must be configured according to the recommendations in the user manual (do not exceed the recommended maximum current value). Otherwise, there is a risk of inverter failure.

### Backup Wiring Diagram TT System

The following diagram is an example for grid systems without special requirement on wiring connection.

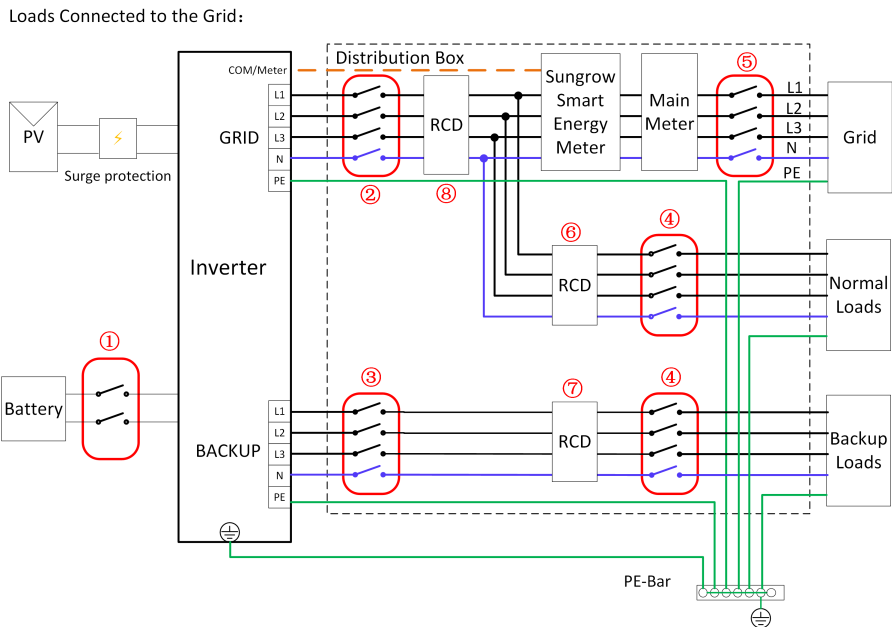

NO.	SH110CX/SH125CX
①	250A/1000V DC breaker *
②	320-400A/400V ** TypeA AC breaker ( $I_{max}$ : 400A)
③	250A/400V TypeA AC Breaker ( $I_{max}$ : 250A)

NO.	SH110CX/SH125CX
④	Depends on loads
⑤	Depends on loads and inverter capacity
⑥⑦	30mA RCD (Comply with local regulation)
⑧	SH125CX: 1250mA RCD (Comply with local regulation) SH110CX: 1100mA RCD (Comply with local regulation)

1. \*If the battery is integrated with a readily accessible internal DC breaker, no additional DC breaker is required.

2. \*\*Select an MCB with an appropriate rated current based on the actual requirements, including the overall wiring scheme, the number of loads, and the inverter's load-carrying capacity.

3. The values in the table are recommended values and can be set to other values according to actual conditions.

4. To improve the safety of the system, set the "Import Power Limit" for the inverter immediately after completing the wiring. The formula used to calculate the import power limit should be: Set value of Import Power Limit (kW)  $\leq 3 \times 230 \times 0.8 \times$  rated current of the main switch.



The specifications of the AC breaker must be configured according to the recommendations in the user manual (do not exceed the recommended maximum current value). Otherwise, there is a risk of inverter failure.

### Whole Site Backup Wiring Diagram TT System

The following diagram is an example for grid systems without special requirement on wiring connection.

Whole Home Backup:

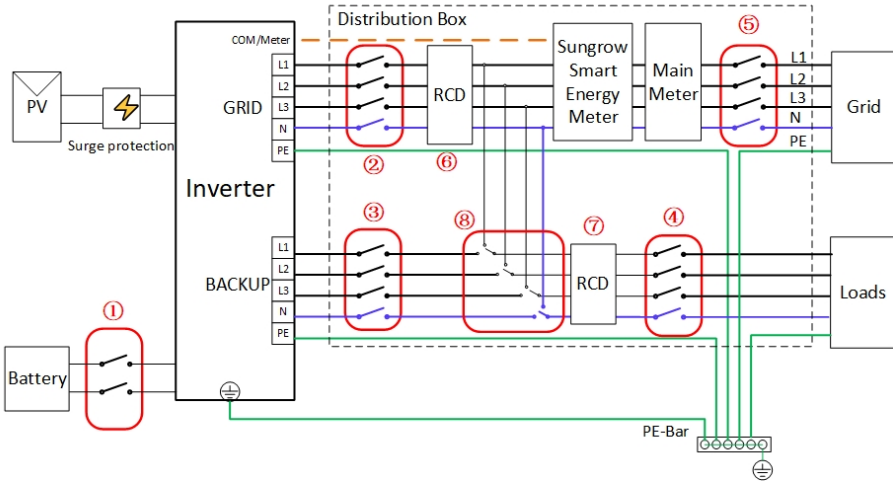

NO.	SH110CX/SH125CX
①	250A/1000V DC breaker
②	320~400A/400V TypeA AC breaker ( $I_{max}$ : 400A)
③	250A/ 400V TypeA AC Breaker ( $I_{max}$ : 250A)
④	Depends on loads
⑤	Depends on loads and inverter capacity
⑥	SH125CX: 1250mA RCD (Comply with local regulation) SH110CX: 1100mA RCD (Comply with local regulation)
⑦	30mA RCD (Comply with local regulation)
⑧	$\geq 320\sim 400A/400V$ manual changeover switch*

\*The manual changeover switch should be prepared by users separately. For the whole site backup scenario, it is recommended to use at least a 320A manual changeover switch, with 400A preferred. When switching to "BACKUP" using the changeover switch, loads will be supplied by the PV installation and battery. When the inverter is faulty or undergoing maintenance, switch to "GRID" to ensure the loads can work normally.

**i** The specifications of the AC breaker must be configured according to the recommendations in the user manual (do not exceed the recommended maximum current value). Otherwise, there is a risk of inverter failure.

## 7.4 Crimp OT/DT terminal

### Crimp OT/DT terminal

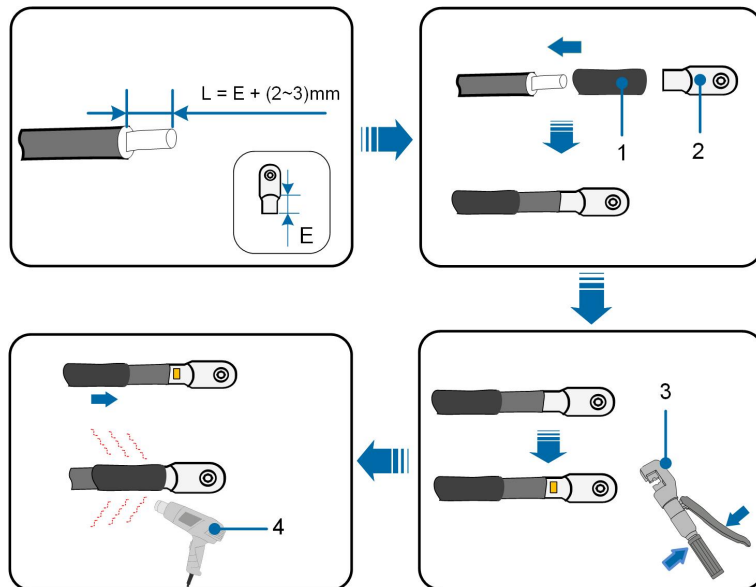

(1) Heat shrink tubing

(2) OT/DT terminal

(3) Hydraulic pliers

(4) Heat gun

### Aluminum Wire Requirements

If aluminum wires are selected, use copper-aluminum bimetallic terminals, avoiding direct contact between the copper bar and the aluminum wire.

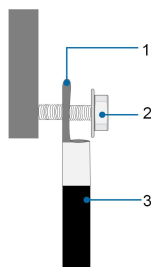

**Figure 7-2** Aluminum Wire Terminal Connection Sequence

(1) Copper-aluminum  
bimetallic terminals

(2) Nut

(3) Aluminum wire

**NOTICE**

- Ensure that the selected terminal can directly contact the copper bar. If uncertain, , contact the terminal manufacturer.
- Ensure that the copper bar is not in direct contact with the aluminum wire. Otherwise, electrochemical corrosion may occur, impairing the reliability of the electrical connections.

## 7.5 External Protective Grounding Connection

**⚠ DANGER**

- When the inverter is powered on and running, high current is present. Powering the unit without proper grounding poses a risk of electric shock and may disable essential protection features such as lightning protection. Therefore, before powering on the inverter, ensure that the inverter is reliably grounded. Damages caused by failure to comply are not covered under warranty.
- During electrical connections, grounding must be the first and highest-priority step.

**⚠ WARNING**

- Since the inverter is transformerless, neither the positive nor the negative terminals of the PV strings can be grounded. Otherwise, the inverter will not operate normally.
- The external protective grounding connection must be completed before making any AC, PV string, or communication connections.
- The external protective grounding point provides a reliable ground connection. Do not use an improper grounding conductor for grounding, Otherwise, it may cause product damage or personal injury.

**⚠ WARNING**

The external protective grounding terminal must meet at least one of the following requirements:

- If the grounding cable cross-sectional area  $\geq 10 \text{ mm}^2$  (copper) or  $16 \text{ mm}^2$  (aluminum), it is recommended to ground both the external protective grounding terminal and the AC side grounding terminal.
- If the grounding cable cross-sectional area  $< 10 \text{ mm}^2$  (copper) or  $16 \text{ mm}^2$  (aluminum), ensure both the external protective ground terminal and AC side ground terminal are grounded.

Other grounding schemes, which meet the local standards and safety regulations, may also be adopted. However, SUNGROW shall not be held liable for any consequence caused thereby.

### 7.5.1 Requirements for External Protective Grounding

In PV power generation systems, all non-current-carrying metal parts and equipment enclosures must be grounded (e.g., PV mounting structures, inverter enclosures, etc.).

For a single inverter, the external protective grounding terminal must be grounded locally.

For systems with multiple inverters, connect all external protective grounding terminals and PV mounting structure grounding points to an equipotential bonding conductor (specific operations depend on site conditions) to ensure equipotential bonding.

### 7.5.2 Wiring Steps

**Step 1** Prepare the cable by crimping the OT/DT terminal. Refer to [Crimp OT/DT terminal](#) for details.

**Step 2** Remove the screw from the grounding terminal and use a screwdriver to secure the cable.

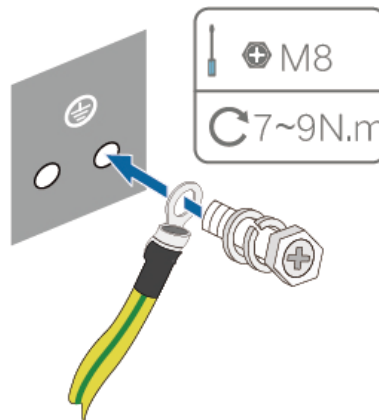

**Step 3** Apply paint to the grounding terminal to improve its anti-corrosion performance.

**i** Two external protective grounding terminals are available. Use at least one of them for grounding.

**i** The resistance of the inverter's grounding bolt to the ground should be  $\leq 4\Omega$ , and the resistance should be tested and checked every half a year.

- i**
  - In each PV string, the metal frames of two adjacent modules must be connected using a reliable 4 mm<sup>2</sup> yellow-green wire.
  - The first and last module in each string must be connected to the mounting structure using a yellow-green wire.

--End

## 7.6 AC Cable Connection

### 7.6.1 AC side Requirements



The inverter can only be connected to the utility grid with the permission of the local power company.

Before grid connection, confirm that the grid voltage and frequency meet the requirements for the inverter operation. See "**Technical Data**" for detailed parameters. If requirements are not met, contact the power company for help.

#### AC circuit breaker

An independent three-pole or four-pole circuit breaker must be installed on the AC output side of each inverter to ensure safe disconnection from the grid.

Inverter	Recommended Rated Voltage	Recommended Rated Current
SH110CX, SH125CX	400 V	Grid side: 400 A Load side: 250 A

#### **WARNING**

- **Install an AC circuit breaker between the inverter AC side and the grid, to ensure the inverter can disconnect from the grid in a safe manner.**
- **Multiple inverters must not share a single AC circuit breaker.**
- **Do not connect any local load between the inverter and the AC circuit breaker.**

#### Requirements for Multiple Inverters in Parallel Connection

Where multiple inverters are connected to the grid in parallel, the total number of parallel inverters must not exceed 24. If more than 24 inverters need to be connected, contact SUNGROW to validate the technical solution.

#### MV Transformer

The MV transformer used together with the inverter should meet the following requirements:

- A distribution transformer can be used. The transformer should be suitable for a PV system with a typical cyclical load pattern (with loads during the daytime and no load at night).
- A dry-type transformer or an oil-immersed transformer can be used, and the shield winding is not required.
- The line voltage on the LV side of the transformer must match the line voltage on the AC output side of the inverter. To connect to a power grid that adopts the IT system, the withstand voltage to ground of the step-up transformer's LV winding, the AC cables, and the secondary equipment (such as the protective relay, detection and measuring device, and other related auxiliary devices) must not be lower than the system voltage of 1100 V.

- Two double-split windings in the same phase of the transformer must be able to withstand a system voltage of at least 1100 V.
- The line voltage on the HV side of the transformer must be consistent with the voltage rating of the grid at the installation site.
- To keep the voltage consistent with the grid voltage, a transformer with a tap changer on the HV side is recommended.
- The operating capacity of the transformer should meet the inverter's output requirements. At an ambient temperature of 30 °C, the transformer should be able to operate continuously under 1.1 times overload conditions.
- A transformer with a short-circuit impedance of 7% (allowable tolerance:  $\pm 10\%$ ) is recommended.
- The voltage drop of system cable must not exceed 3%.
- The DC component that the transformer can withstand is 1% of the fundamental current at rated power.
- Regarding the thermal rating, the load profile of the inverter and the environmental conditions at the installation site must be taken into account.
- The apparent power of the inverter must not exceed the transformer power. The maximum AC current of all inverters connected in parallel must be taken into account. If more than 24 inverters need to be connected to the grid, contact SUNGROW to validate the technical solution.
- The transformer must have overload and short-circuit protection features.
- As a critical component of the grid-connected PV system, the transformer's capability to withstand system faults must be taken into account. The faults include: system short circuit, grounding fault, voltage drop, etc.
- Take into account the environmental conditions, such as the ambient temperature, relative humidity, altitude, and air quality, when selecting and installing the transformer.

### 7.6.2 OT/DT Terminal Requirements

OT/DT terminals (not included in the scope of delivery) are required for AC cable connections. Please prepare the OT/DT terminals by following the requirements below.

#### OT/DT Terminals for AC Phase Wires

- Specification: M12

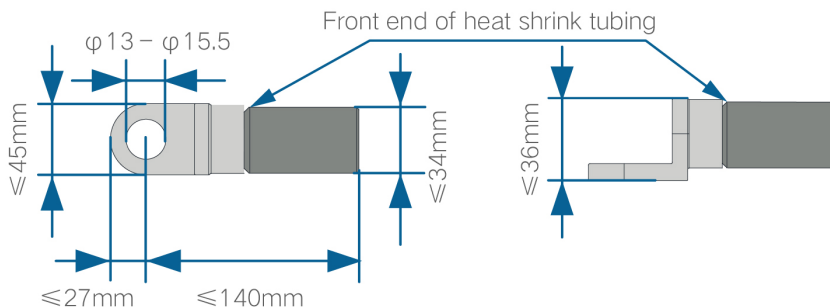

**Figure 7-3** Dimensions of Terminal After Crimping

### OT/DT Terminal for AC PE wire

- Specification: M12

### 7.6.3 AC Cable Connection

- For motor-type loads, wiring must strictly follow phase sequence requirements to ensure that the phase sequence remains consistent from the inverter's AC terminals to the load. Specifically, the inverter's L1, L2, and L3 must be connected to the load's L1, L2, and L3 in the correct order; otherwise, device malfunctions may occur.
-  If abnormal operation is observed, power off the inverter first. Then interchange any two phase conductors on the grid side (or at the grid terminals of the distribution cabinet). If the issue persists, adjust the phase conductors on the load side following the same steps. Repeat this adjustment process until the load operates normally.
- When a parallel system with all backup ports one load, the AC cable length from inverter grid/backup port to the busbar should be kept as equal as possible.

#### 7.6.3.1 Wiring Steps (for 8-hole terminal block/ multi-core cable)

-  This section gives instructions on wiring using a five-core cable. These steps apply to the four-core cable as well.

**Step 1** Switch off the AC side circuit breaker and prevent it from switching on inadvertently.

**Step 2** Loosen the two screws on the front door of the junction box using the Allen wrench (included in the scope of delivery). Then, open the door of the junction box. During wiring, ensure the retaining rod on the junction box keeps its door open.

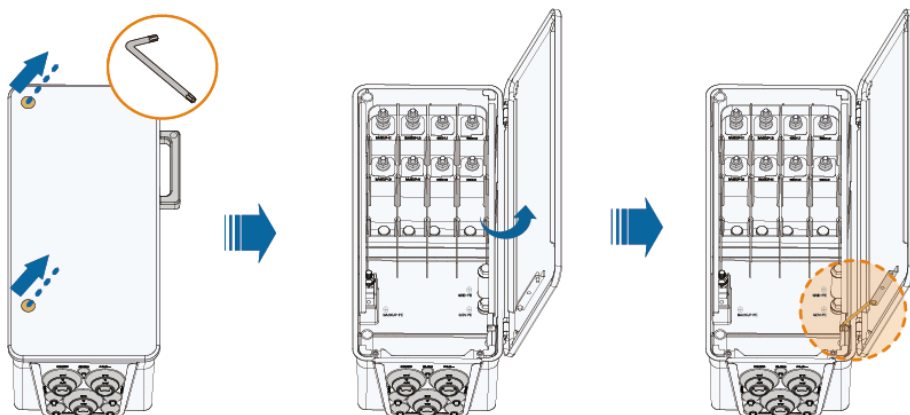

-  The screws on the door of the junction box are captive screws. After the door is opened, the screws stay on the door and hence will not be lost.

**Step 3** Loosen the screws on the bottom sealing plate using the Allen wrench and take the plate out.

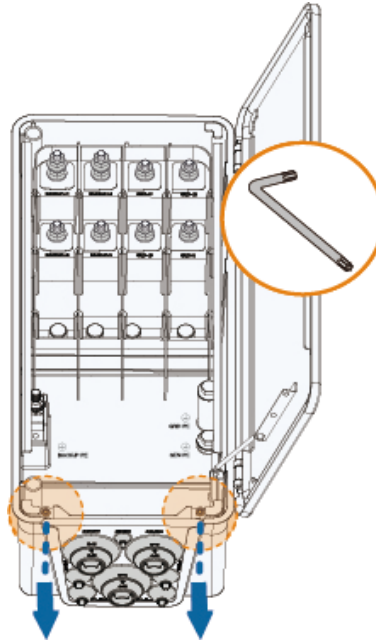

The screws on the sealing plate are captive screws. After the sealing plate is removed, the screws remain on the plate and will not be lost.

**Step 4** Remove the sealing plug of the BACKUP/GRID terminal's rubber grommet as needed and secure the terminal block with screws.

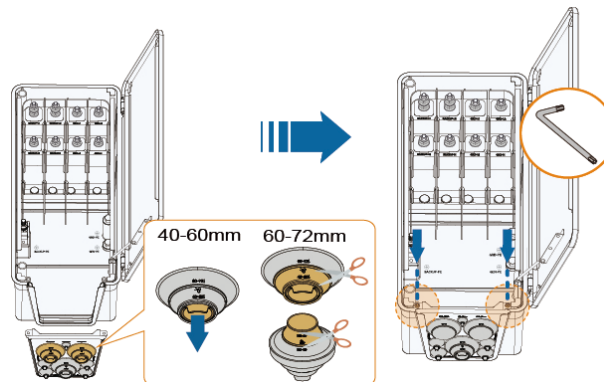

**Step 5** Wire as needed in the following order:

### NOTICE

**Pay attention to the connection of the PE and N wires. Connecting a phase wire to the terminal for the PE or N wire may lead to permanent damage to the inverter.**

Ensure that the inner depth L of the socket used is  $\geq 28\text{mm}$ .

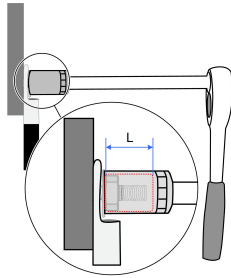

a. Connect the backup cable.

1. Pass the unstripped cable through the corresponding rubber grommet.

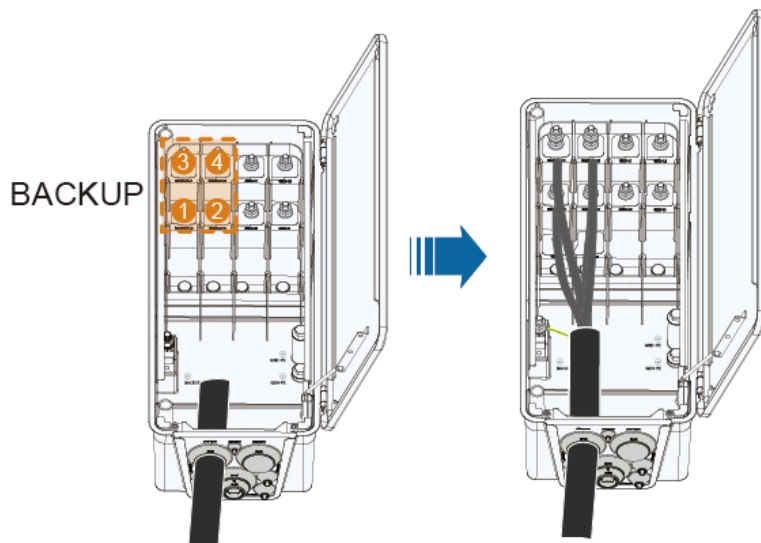

The numbering in the diagram indicates the wiring sequence only.

2. Strip the external protective layer of the AC cable inside the junction box, by referring to the figure below. Pass the stripped conductors through the heat shrink tubes and crimp the OT/DT terminals onto them.

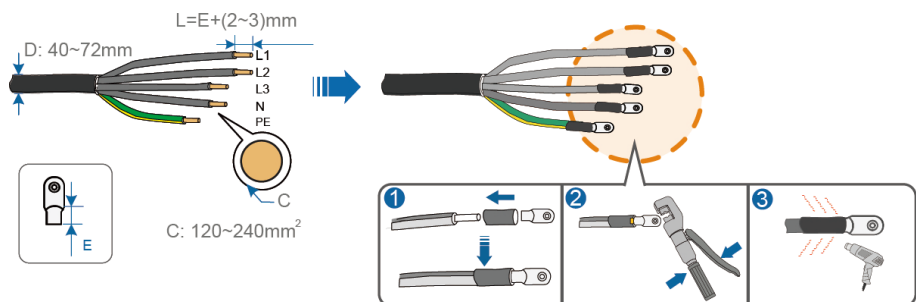

**NOTICE**

When using a multi-core cable, strip L1 and L2 conductors 60 mm longer than L3 and N conductors.

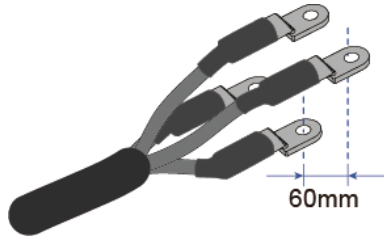

3. After crimping, gently pull the conductors back to verify that the rubber grommet is properly seated (outer side convex, inner side concave) and then fix them to the corresponding terminals.

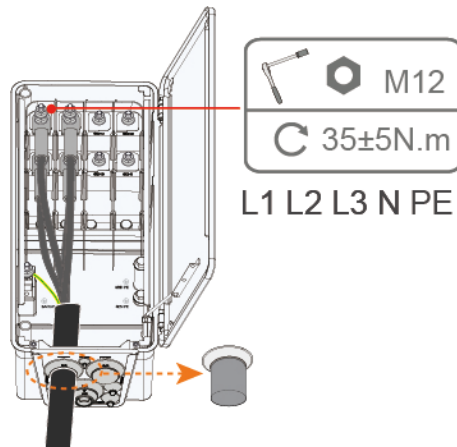

- b. Connect the grid cable.

1. Pass the unstripped cable through the corresponding rubber grommet.

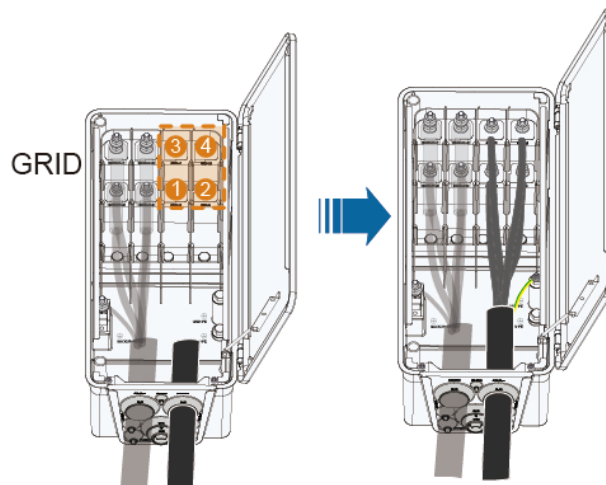

**i** The numbering in the diagram indicates the wiring sequence only.

- Strip the external protective layer of the AC cable inside the junction box, by referring to the figure below. Pass the stripped conductors through the heat shrink tubes and crimp the OT/DT terminals onto them.

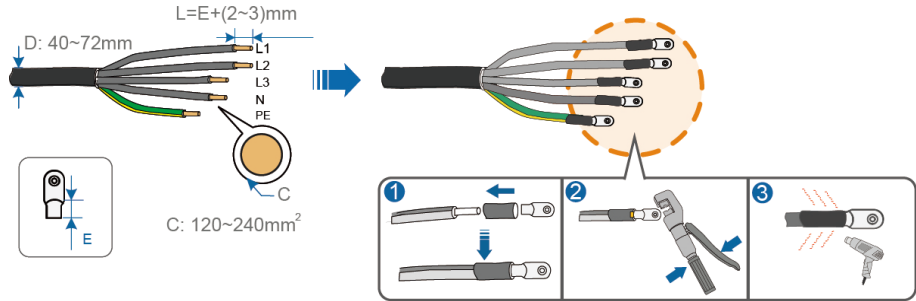

**NOTICE**

When using a multi-core cable, strip L1 and L2 conductors 60 mm longer than L3 and N conductors.

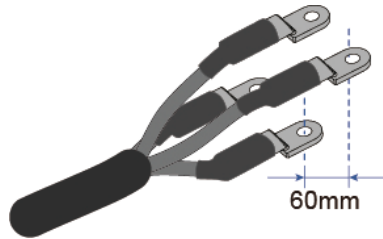

- After crimping, gently pull the conductors back to verify that the rubber grommet is properly seated (outer side convex, inner side concave) and then fix them to the corresponding terminals.

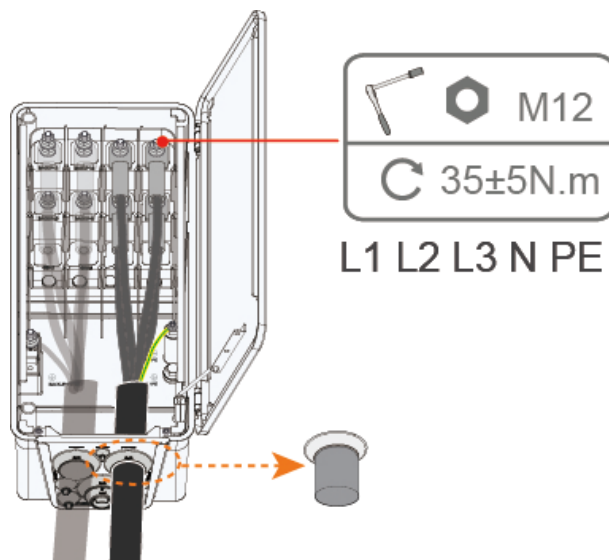

c. Connect the battery auxiliary power cable



This step applies only to the supporting battery that needs to be powered from the BACKUP port.

Type	Outer Diameter (mm)	Cross-sectional area of conductor (mm <sup>2</sup> )
Battery auxiliary power cable	8 - 16	0.5 - 10

1. Remove the sealing plug of the battery auxiliary power terminal's rubber grommet, then pass the unstripped cable through the corresponding rubber grommet.

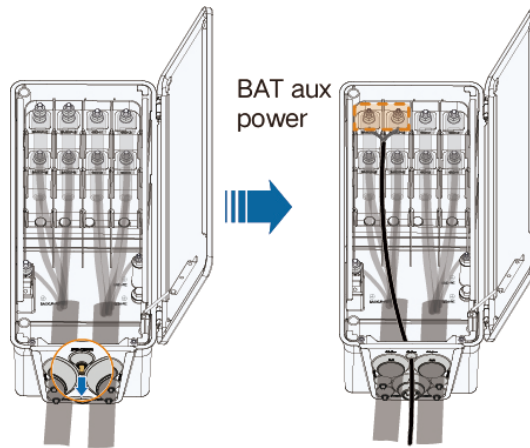

2. Strip the external protective layer of the AC cable inside the junction box, by referring to the figure below. Pass the stripped conductors through the heat shrink tubes and crimp the OT/DT terminals onto them.

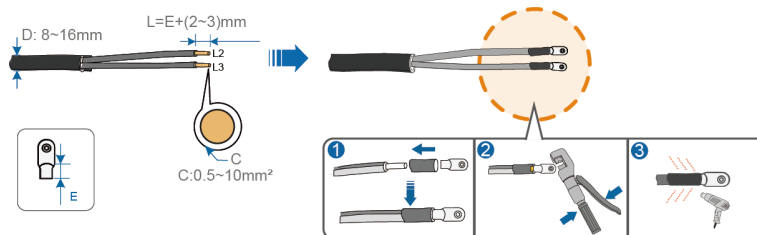

3. After crimping, gently pull the conductors back to verify that the rubber grommet is properly seated (outer side convex, inner side concave) and then fix them to the corresponding terminals.

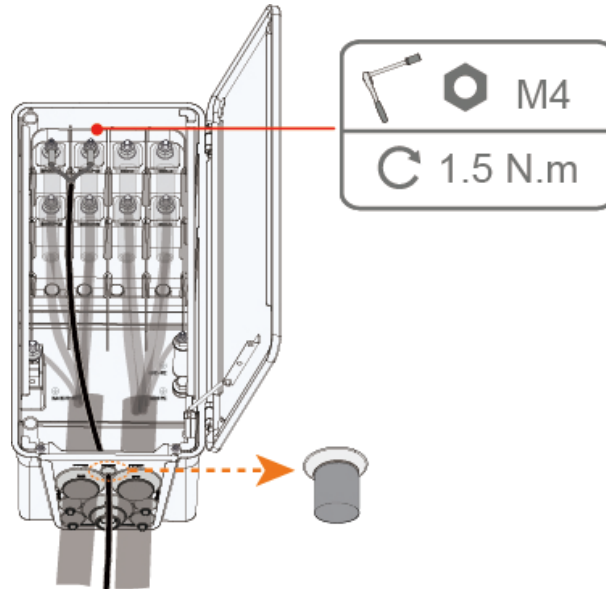

**Step 6** Apply fireproof mud around the rubber grommets where cables enter the terminal block.

**Step 7** Remove the door retaining rod and put it back in its original position. Close the door of the junction box, and tighten the two screws on the door using the Allen wrench.

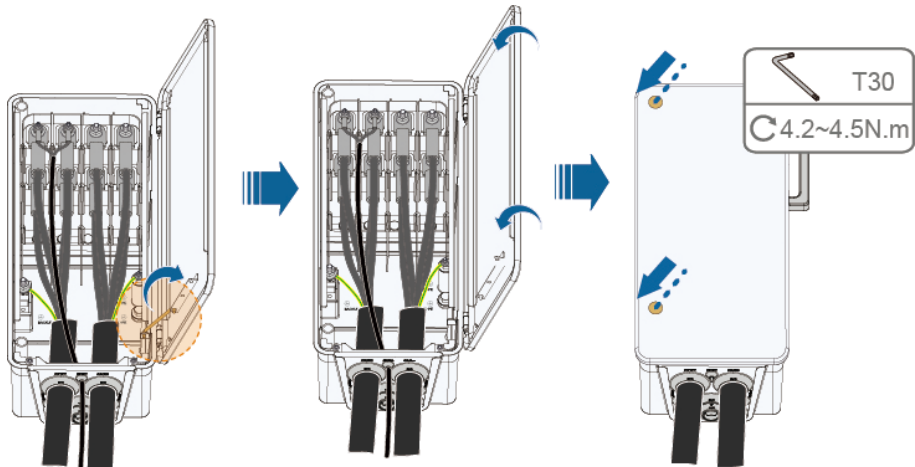

\*The figures shown are for reference only. The actual product may differ.

--End

### 7.6.3.2 Wiring Steps (for 16-hole terminal block/ single-core cable)

**Step 1** Switch off the AC side circuit breaker and prevent it from switching on inadvertently.

**Step 2** Loosen the two screws on the front door of the junction box using the Allen wrench (included in the scope of delivery). Then, open the door of the junction box. During wiring, ensure the retaining rod on the junction box keeps its door open.

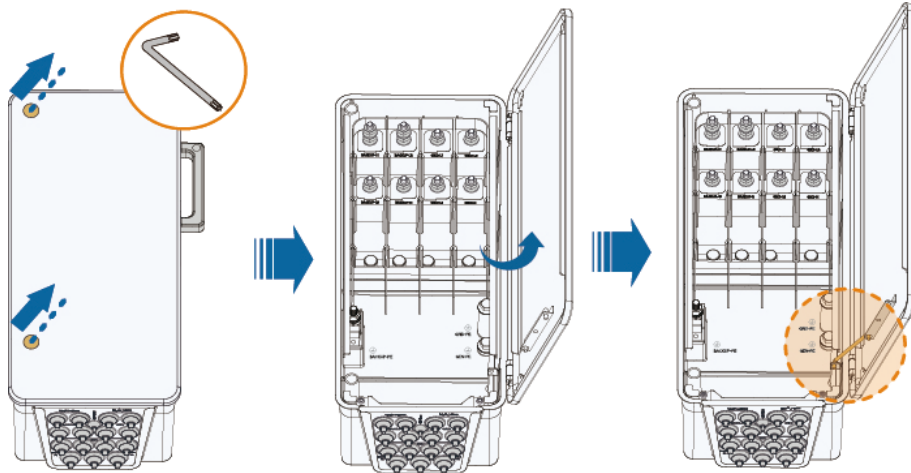

The screws on the door of the junction box are captive screws. After the door is opened, the screws stay on the door and hence will not be lost.

**Step 3** Loosen the screws on the bottom sealing plate using the Allen wrench and take the plate out.

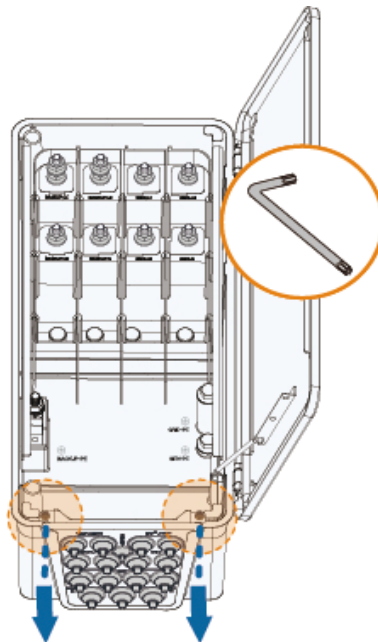

The screws on the sealing plate are captive screws. After the sealing plate is removed, the screws remain on the plate and will not be lost.

**Step 4** Remove the sealing plug of the PE/BACKUP/GRID terminal's rubber grommet as needed, secure the terminal block with screws. Wire as needed in the following order:

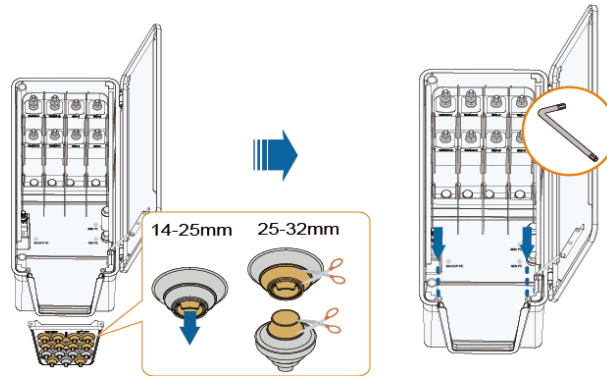

### NOTICE

**Pay attention to the connection of the PE and N wires. Connecting a phase wire to the terminal for the PE or N wire may lead to permanent damage to the inverter.**

Ensure that the inner depth L of the socket used is  $\geq 28\text{mm}$ .

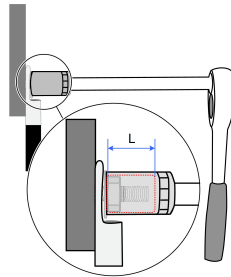

- a. Connect the PE cable
  1. Pass the unstripped cable through the corresponding rubber grommet.

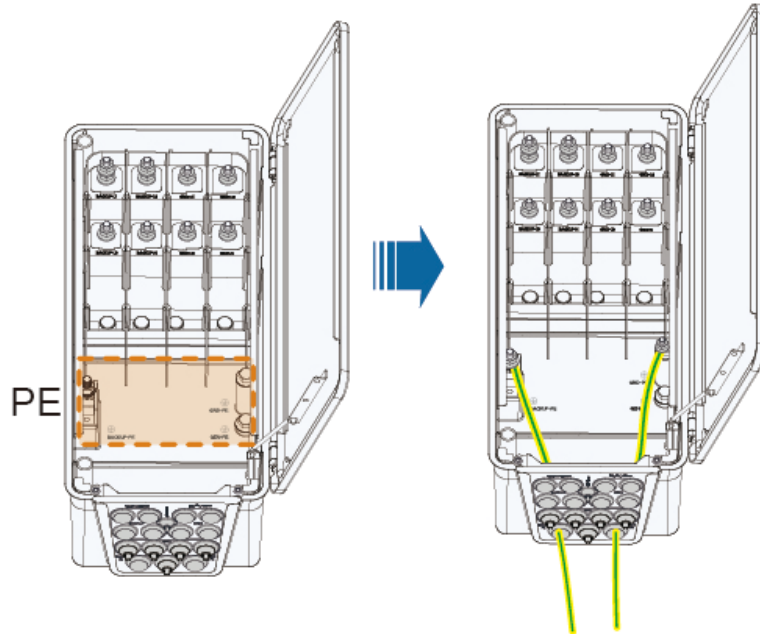

- Strip the external protective layer of the PE cable inside the junction box, by referring to the figure below. Pass the stripped conductors through the heat shrink tubes and crimp the OT/DT terminals onto them.

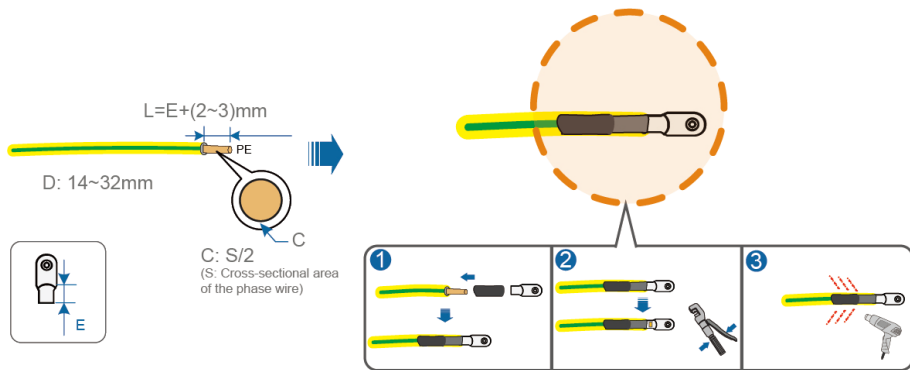

- After crimping, gently pull the conductors back to verify that the rubber grommet is properly seated (outer side convex, inner side concave) and then fix them to the corresponding terminals.

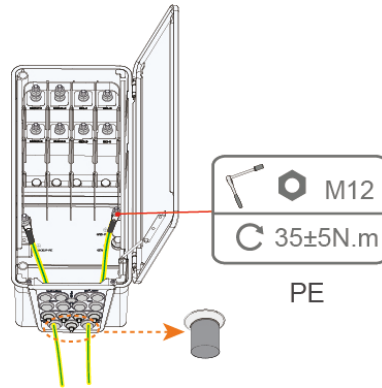

**b. Connect the backup cable.**

1. Pass the unstripped cable through the corresponding rubber grommet.

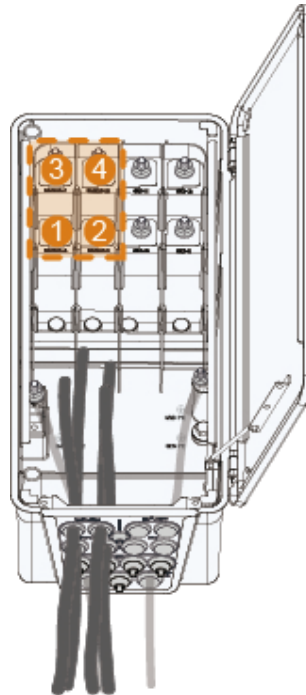

The numbering in the diagram indicates the wiring sequence only.

2. Strip the external protective layer of the AC cable inside the junction box, by referring to the figure below. Pass the stripped conductors through the heat shrink tubes and crimp the OT/DT terminals onto them.

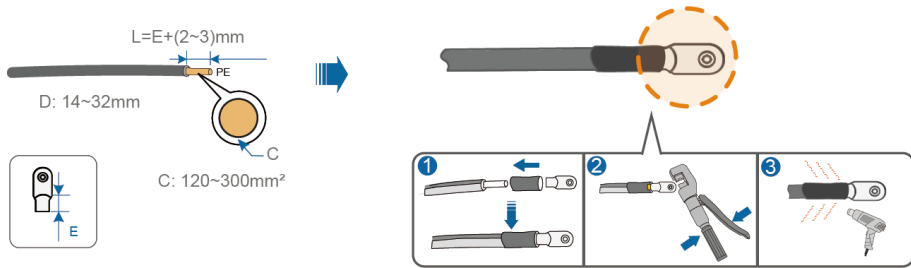

3. After crimping, gently pull the conductors back to verify that the rubber grommet is properly seated (outer side convex, inner side concave) and then fix them to the corresponding terminals.

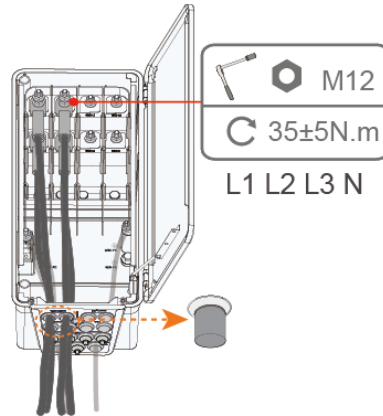

c. Connect the grid cable.

1. Pass the unstripped cable through the corresponding rubber grommet.

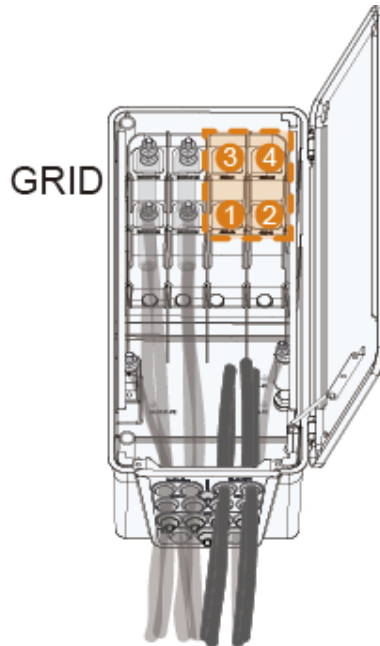

**i** The numbering in the diagram indicates the wiring sequence only.

- Strip the external protective layer of the AC cable inside the junction box, by referring to the figure below. Pass the stripped conductors through the heat shrink tubes and crimp the OT/DT terminals onto them.

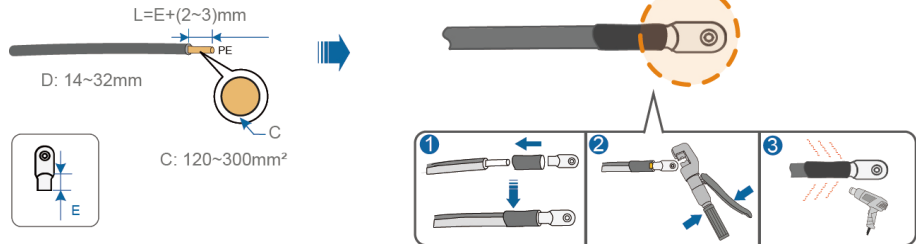

**NOTICE**

**After crimping, ensure the center points of all OT/DT terminals are aligned horizontally.**

- After crimping, gently pull the conductors back to verify that the rubber grommet is properly seated (outer side convex, inner side concave) and then fix them to the corresponding terminals.

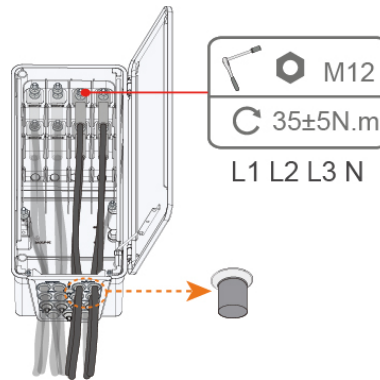

- Connect the battery auxiliary power cable

**i** This step applies only to the supporting battery that needs to be powered from the BACKUP port.

Type	Outer Diameter (mm)	Cross-sectional area of conductor (mm <sup>2</sup> )
Battery auxiliary power cable	8 - 16	0.5 -10

1. Remove the sealing plug of the battery auxiliary power terminal's rubber grommet, secure the terminal block with screws, then pass the unstripped cable through the corresponding rubber grommet.

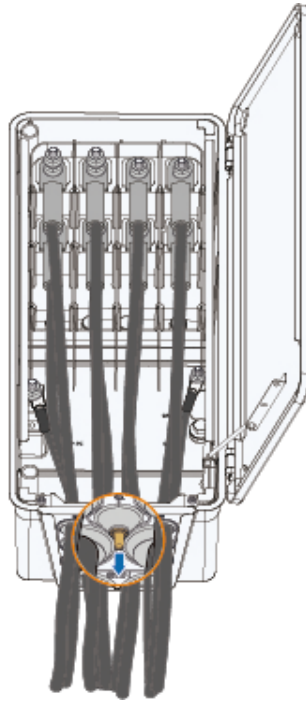

2. Strip the external protective layer of the AC cable inside the junction box, by referring to the figure below. Pass the stripped conductors through the heat shrink tubes and crimp the OT/DT terminals onto them.

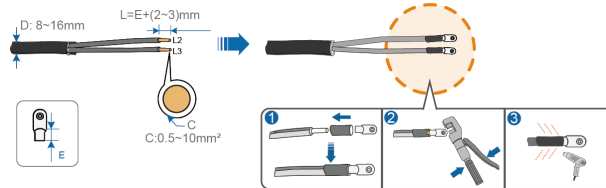

3. After crimping, gently pull the conductors back to verify that the rubber grommet is properly seated (outer side convex, inner side concave) and then fix them to the corresponding terminals.

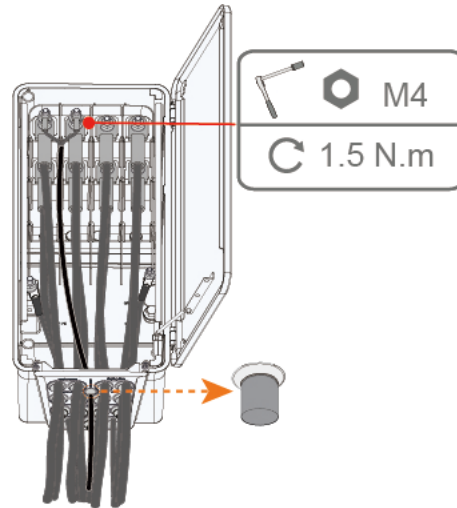

**Step 5** Apply fireproof mud around the rubber grommets where cables enter the terminal block.

**Step 6** Remove the door retaining rod and put it back in its original position. Close the door of the junction box, and tighten the two screws on the door using the Allen wrench.

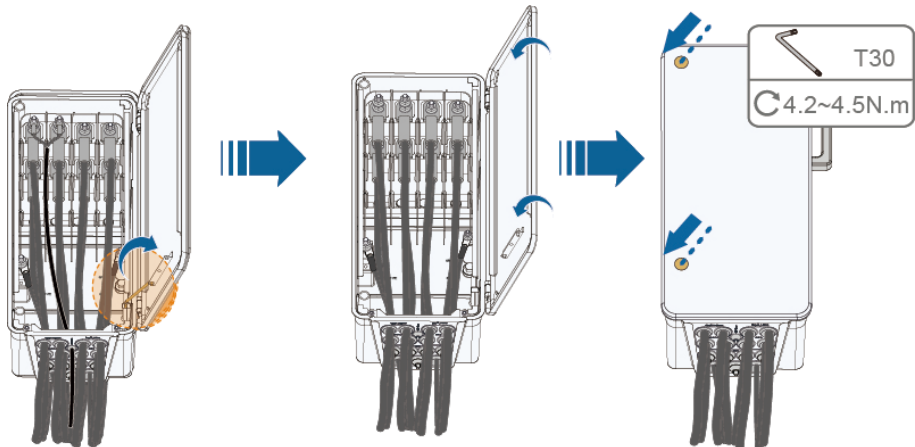

\*The figures shown are for reference only. The actual product may differ.

--End

## 7.7 DC Cable Connection

### **⚠ DANGER**

**Hazardous voltages on the PV string when it is exposed to sunlight!**

- Observe all the safety instructions listed in the documents for the PV string and other relevant documents.

**⚠ WARNING**

- **Make sure the PV array is well insulated to the ground before connecting it to the inverter.**
- **Make sure the maximum DC voltage and the maximum short circuit current of any string never exceed inverter permitted values specified in “Technical Data.”**
- **Check the positive and negative polarity of the PV strings, and connect the PV connectors to corresponding terminals only after ensuring polarity correctness.**
- **During the installation and operation of the inverter, please ensure that the positive or negative electrodes of PV strings do not short-circuit to the ground. Otherwise, an AC or DC short-circuit may occur, resulting in equipment damage. The damage caused by this is not covered by the warranty.**
- **Electric arc or contactor over-temperature may occur if the DC connectors are not firmly in place, and the loss caused is not covered by the warranty.**
- **If the DC input polarity is reversed or both the positive and negative terminals of different MPPTs are shorted to ground while the DC switches are set to the ON position, do not operate the inverter immediately, as this may cause damage. Wait until string current drops below 0.5 A, turn DC switches OFF, and disconnect the DC connectors to adjust string polarity.**
- **The inverter does not support the full parallel connection of PV strings (Full parallel connection refers to a connection method in that strings are connected in parallel and then connected to the inverter separately).**
- **Do not connect one PV string to multiple inverters. Otherwise, the inverters may be damaged.**

**NOTICE**

The following requirements about PV string connection must be met. Otherwise, it may cause irreversible damage to the inverter, which is not covered by the warranty.

- **Mixed use of different brand or model of PV modules in one MPPT circuit, or PV modules of different orientation or angles in a string will not necessarily damage the inverter but may degrade system performance.**
- **The inverter enters standby state when the input voltage ranges between 1000 V and 1100 V. The inverter returns to running state once the voltage returns to the MPPT operating voltage range (180 V to 1000 V).**

**NOTICE**

Note the following items when laying out cables on site:

- The axial tensile force of DC cables on PV DC connectors must be <80 N.
- Avoid prolonged axial stress on connectors during wiring.
- Maintain ≥50 mm unbent length at cable roots to prevent bending-induced stress from affecting waterproofing.
- Follow the cable manufacturer’s requirements for minimum bending radius. If <50 mm, enforce 50 mm (connector requirement); if >50 mm, follow the cable’s actual minimum bending radius.

**7.7.1 PV Input Configuration**

- The inverter supports multiple PV inputs and provides MPP trackers for all PV inputs, as shown in the figure below.
- The inverter offers several independently operating MPPTs for the PV inputs. Therefore, the configuration of PV strings, such as the model and number of PV modules and tilt and azimuth angles, connected to one MPPT can be different from those connected to another.
- Up to 2 PV strings can be connected to one MPPT. For the best use of their input power, make sure the PV strings connected to the same MPPT are identical in configuration, such as the model and number of PV modules and tilt and azimuth angles.
- The voltage difference between the maximum MPPT voltage and the minimum MPPT voltage shall be ≤ 250V, and there is no limitation on MPPT current.

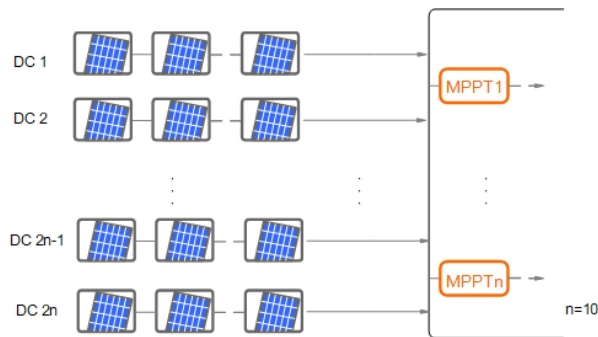

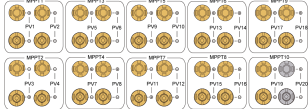
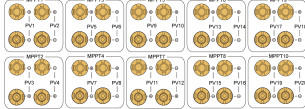

**Figure 7-4** PV Input Configuration

Prior to connecting the PV strings to the inverter, make sure the strings all meet the below requirements:

Open-circuit Voltage Limit of Each Input	Max. Current for Input Connector
1100 V	30 A

If the number of PV strings is 10 to 20, it is recommended to perform DC input wiring by referring to the table below.

Number of PV Strings	DC PV Terminals	Number of PV Strings	DC PV Terminals
10	Connect to PV1, PV3, PV5, PV7, PV9, PV11, PV13, PV15, PV17, PV19	11	Connect to PV1, PV2, PV3, PV5, PV7, PV9, PV11, PV13, PV15, PV17, PV19
12	Connect to PV1, PV2, PV3, PV4, PV5, PV7, PV9, PV11, PV13, PV15, PV17, PV19	13	Connect to PV1, PV2, PV3, PV4, PV5, PV6, PV7, PV9, PV11, PV13, PV15, PV17, PV19
14	Connect to PV1, PV2, PV3, PV4, PV5, PV6, PV7, PV8, PV9, PV11, PV13, PV15, PV17, PV19	15	Connect to PV1, PV2, PV3, PV4, PV5, PV6, PV7, PV8, PV9, PV10, PV11, PV13, PV15, PV17, PV19
16	Connect to PV1, PV2, PV3, PV4, PV5, PV6, PV7, PV8, PV9, PV10, PV11, PV12, PV13, PV15, PV17, PV19	17	Connect to PV1, PV2, PV3, PV4, PV5, PV6, PV7, PV8, PV9, PV10, PV11, PV12, PV13, PV14, PV15, PV17, PV19
18	Connect to PV1, PV2, PV3, PV4, PV5, PV6, PV7, PV8, PV9, PV10,	19	Connect to PV1, PV2, PV3, PV4, PV5, PV6, PV7, PV8,

Number of PV Strings	DC PV Terminals	Number of PV Strings	DC PV Terminals
	PV11, PV12, PV13, PV14, PV15, PV16, PV17, PV19		PV9, PV10, PV11, PV12, PV13, PV14, PV15, PV16, PV17, PV18, PV19
20	Connect to PV1, PV2, PV3, PV4, PV5, PV6, PV7, PV8, PV9, PV10, PV11, PV12, PV13, PV14, PV15, PV16, PV17, PV18, PV19, PV20		
			

 The inverter does not support the connection of strings connected in parallel externally.

### 7.7.2 Assemble DC Connector (MC4)

#### Prerequisite

**⚠ CAUTION**

- If the maximum DC input voltage does not exceed 1000 V, use the MC4 DC terminals included with the shipment.
- Use MC4-Evo2 DC terminals if the maximum input voltage is greater than 1000 V. To purchase the MC4-Evo2 DC terminals, please contact SUNGROW.
- Using incorrect connectors may result in device damage and will void the warranty.

 To ensure the inverter operates to an ingress protection rating of IP66, use the connectors that come with the product only.

**Step 1** Strip the insulation layer of the DC cable by a length of about 7 mm.

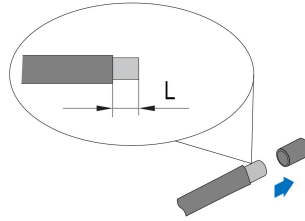

**Step 2** Crimp the terminal onto the cable.

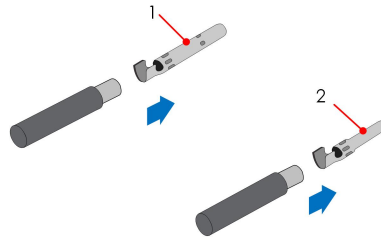

(1) Positive crimp contact

(2) Negative crimp contact

**Step 3** Lead the cable through the cable gland, and insert the cable into the insulator until it snaps into place. Pull gently the cable backward to make sure the connection is secure. Tighten the cable gland and the insulator at a torque of 3.4–3.5 N.m.

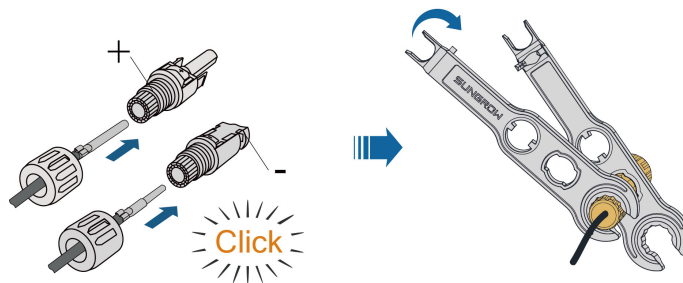

**Step 4** Check and confirm that the PV string cables are connected in the correct polarity.

#### NOTICE

The inverter will report a fault or alarm and not function properly if the positive and negative DC input cables are connected reversely.

--End

### 7.7.3 Installing PV Connector

**Step 1** Rotate the DC switch to "OFF".

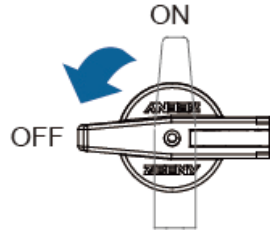

**Step 2** Check that the cables of the PV strings are connected in the correct polarity. Ensure the open-circuit voltage does not exceed the inverter upper-limit input voltage of 1100 V.

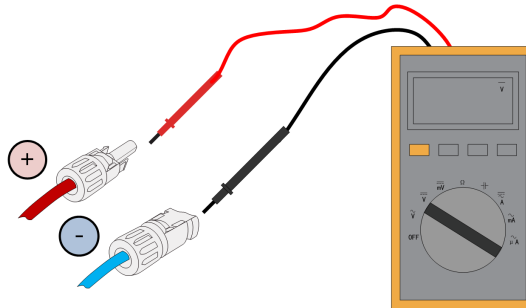

**Step 3** Connect the DC PV connectors to the corresponding terminals until there is an audible click.

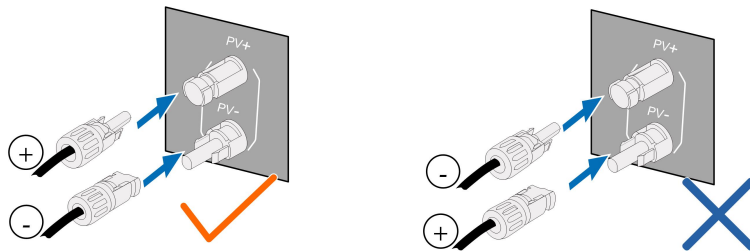

**Step 4** Connect the cables of other PV strings by following the steps above.

**Step 5** Close off the unused PV terminals with the waterproof plugs.

--End

## 7.8 Battery Connection

### 7.8.1 Electrical Connection Requirements

This section covers the battery cable connections on the inverter side. For battery-side wiring and configuration, refer to the battery manufacturer's manual.

#### **⚠ WARNING**

**Use appropriate insulated tools to prevent electric shock or short circuit. If insulated tools are unavailable, cover the exposed metal parts (except the tip) entirely with electrical tape.**

**⚠ WARNING**

Only trained electricians may connect the plug connectors.

**⚠ WARNING**

- Never disconnect under load.
- Battery connectors must not be disconnected under load; they can only be disconnected when the inverter is fully shut down and in no-load condition.

**⚠ WARNING**

During installation and operation of the inverter, ensure that the battery's positive and negative terminals do not short to ground. Otherwise, a short circuit may occur, resulting in device damage. Damage caused by such incidents is not covered under warranty.



- If the inverter is not connected to a battery, it cannot provide reliable backup power.
- The battery must be grounded through the building's PE bar and not directly to the PE terminal of the inverter.
- The battery does not backfeed into the PV modules.

### 7.8.2 Assemble Battery Connector

**Step 1** Strip off the jacket of the cable.

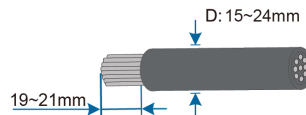

**Step 2** Loosen the nut on the connector, and put the nut and the grommet on the cable.

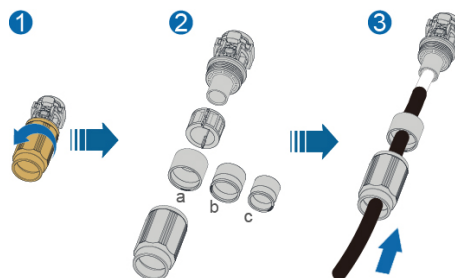

Outer Diameter D(mm)	Sealing Rings
15~18	a+b+c
18~21	a+b

Outer Diameter D(mm)	Sealing Rings
21~24	a

**Step 3** Insert the conductor into the cable lug.

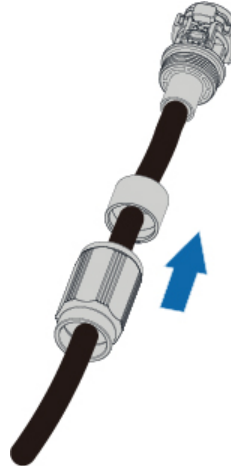

**Step 4** Crimp the lug as shown.

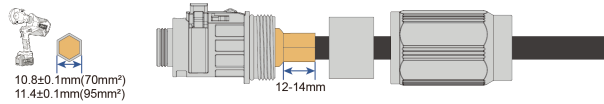

**Step 5** Place the support over the crimped area.

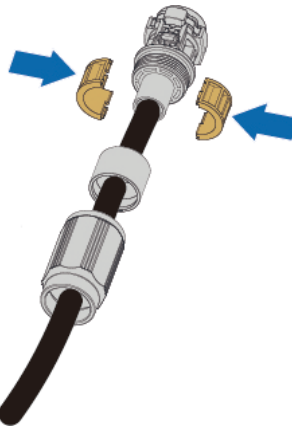

**Step 6** Push the grommet and the nut into the plug, then screw it.

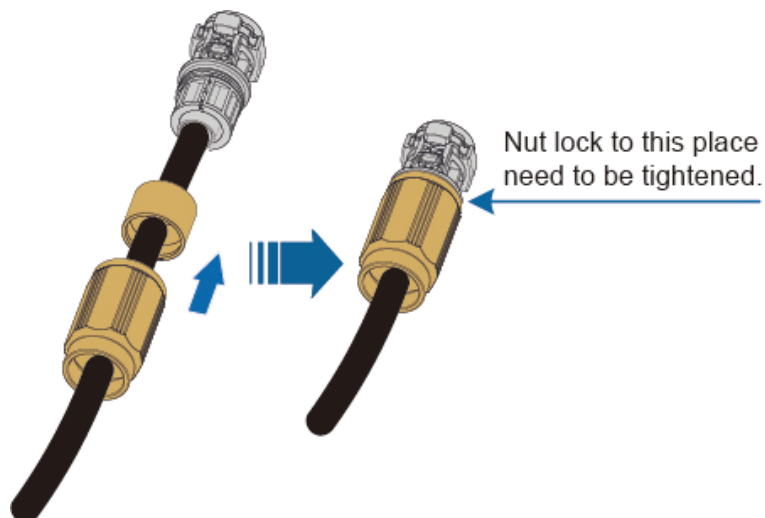

**Step 7** Match plug and socket. Insert the connector into the **BAT+** and **BAT-** terminals.

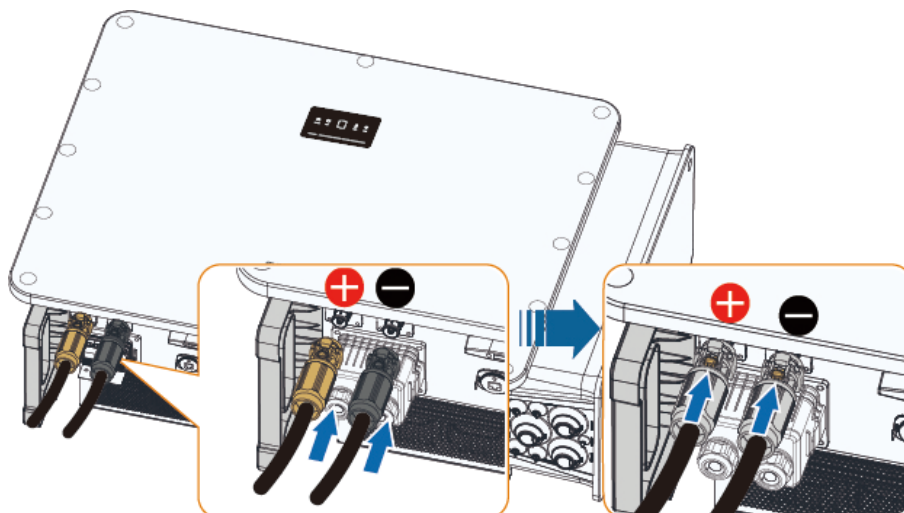

## 7.9 Communication Connection

### 7.9.1 Communication Terminal Cover

**Remove the communication terminal cover**

Squeeze firmly both on sides of the communication terminal cover, and then pull the cover out.

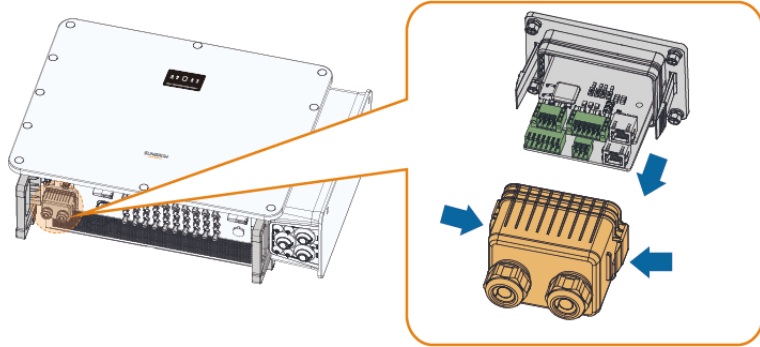

**Mount the communication terminal cover**

Put the cover back in its original position and press it to make it secure in place.

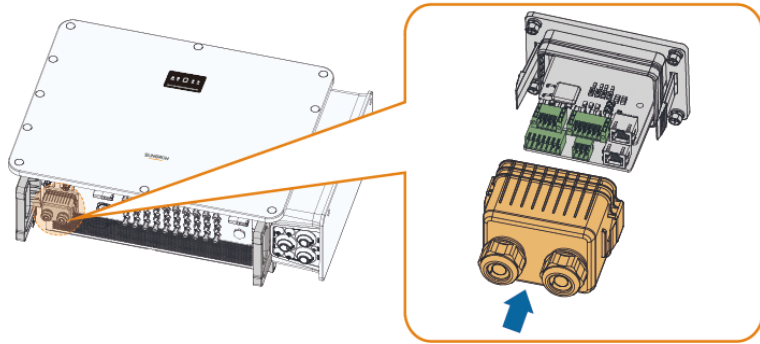

**7.9.2 Communication Wiring Area**

RSD	BAT	DI	Meter				RS485_3		RS485_1		DRM
RSD_2	RSD_2	EN_G	PGND	A2	B2	A3	B3	A1	B1		
RSD_1	RSD_1	EN_H	DI_1	A2	B2	A3	B3	A1	B1		
DO_1 <sup>①</sup>				DO_2	DO_3	PARAL_CAN		BAT_CAN			
COM_1				COM_2	COM_3	H	H	H			
		NO_1		NO_2	NO_3	L	L	L			

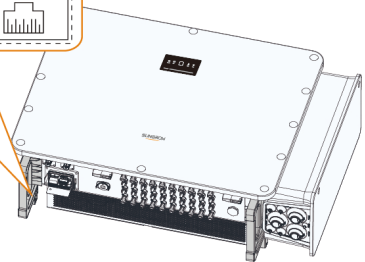

**Table 7-2** Terminal Description

Label	Description
RSD	Connect an external switch to enable the emergency stop function.
BAT	Reserved.

Label	Description
DI	Reserved.
Meter	Connect to the Smart Energy Meter.
RS485_3	Reserved.
RS485_1	The RS485 communication port is used only for the parallel connection of SUNGROW SH110CX/SH125CX hybrid inverters.
DO_1	Grounding fault/alarm.
DO_2	Reserved.
DO_3	Reserved.
PARAL_CAN	For parallel communication between inverters.
BAT_CAN	To enable the communication between the inverter and the Li-on battery.
DRM	<ul style="list-style-type: none"> <li>"AU"/"NZ": Demand response enabling device (DRED)</li> <li>"DE": NS protection</li> <li>"DE": Ripple Control Receiver (RCR)</li> </ul>

**Table 7-3** The label of RJ45 terminal

RJ45–BAT_CAN							
NC	N C	NC	NC	NC	NC	L	H
8	7	6	5	4	3	2	1

  

RJ45–DRM							
NC	N C	C	R	D4/ 8	D3/ 7	D2/ 6	D1/ 5
8	7	6	5	4	3	2	1

### 7.9.3 RS485 Communication Connection

### 7.9.3.1 Interface Description

The RS485 communication interfaces of the inverter are shown in the figure.

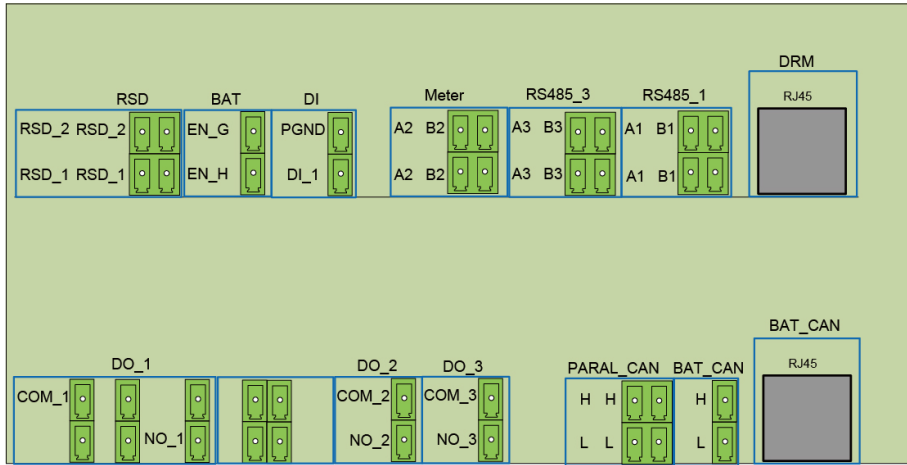

**Table 7-4** RS485\_1 Terminal Block

No.	Definition
A1	RS485A OUT, RS485A differential signal (+)
A1	RS485A IN, RS485A differential signal (+)
B1	RS485B OUT, RS485B differential signal (-)
B1	RS485B IN, RS485B differential signal (-)

**Table 7-5** RS485\_3 Terminal Block

No.	Definition
A3	RS485A OUT, RS485A differential signal (+)
A3	RS485A IN, RS485A differential signal (+)
B3	RS485B OUT, RS485B differential signal (-)
B3	RS485B IN, RS485B differential signal (-)

### 7.9.3.2 RS485 Communication Wiring

#### RS485 Communication of One Inverter

Where only one inverter engages in the communication, only one RS485 communication cable is required for wiring.

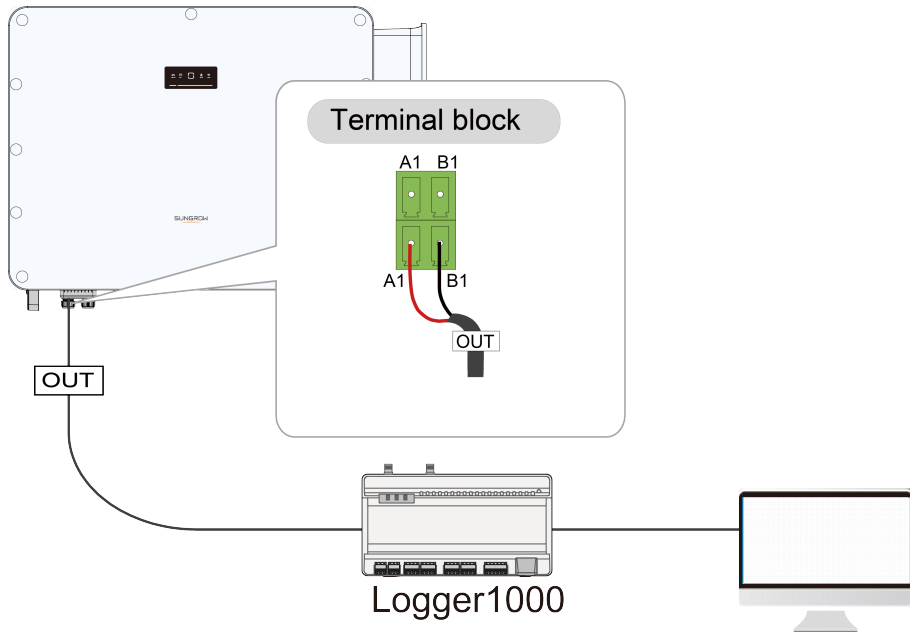

**Multi-inverter Communication System**

Where multiple inverters engage in the communication, connect the inverters in a daisy chain using RS485 communication cables.

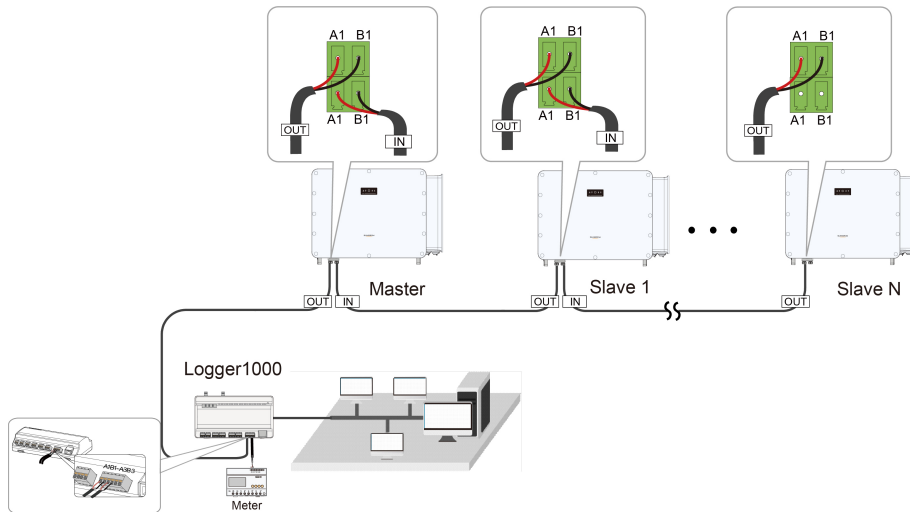

**i** The RS485 communication cable should not be longer than 1200m. If multiple inverters are connected to the intelligent communication box for communication, the maximum number of daisy chains and connected devices should meet the relevant requirements (see the user manual for the communication box).

### 7.9.3.3 Wiring Steps (Terminal Block)

#### 7.9.3.3.1 Wiring Steps for Shielded Twisted Pair

**Step 1** Remove the communication terminal box.

**Step 2** Unscrew the swivel nut on the terminal cover and select an appropriate sealing ring according to the outer diameter of the cable.

**Step 3** Strip the protection layer and insulation layer by specific length.

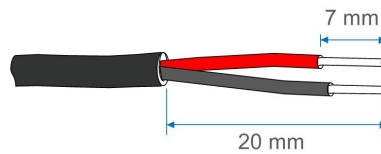

**Step 4** Lead the cable through the swivel nut, the sealing ring, and then the opening on the terminal cover.

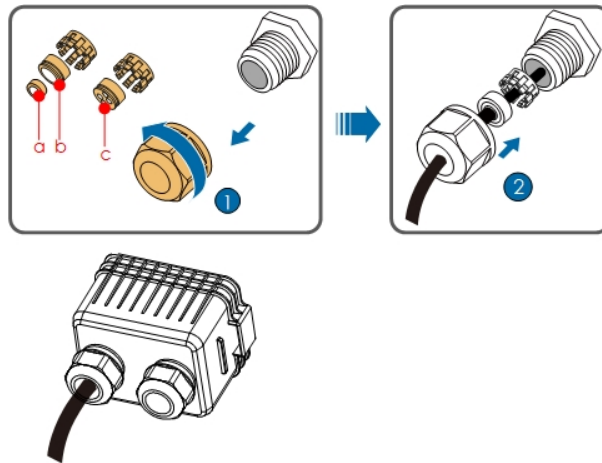

Cable Diameter D (mm)	Sealing Ring
4.5–6	c
6–12	a+b
12–18	b

**Step 5** Fix the wires to the corresponding positions in the terminal block plug.

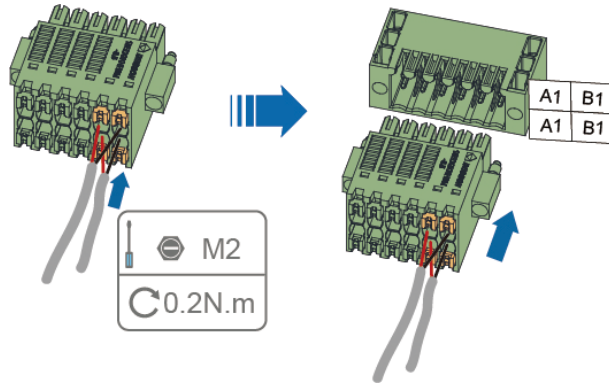

**Step 6** Insert the plug into the corresponding terminal block socket.

**Table 7-6** Terminal Definition

No.	Definition
1	RS485 A (+)
2	RS485 A (+)
3	RS485 B (-)
4	RS485 B (-)

**Step 7** If there are other cables that need to be connected to the communication wiring area, skip the steps below and complete the connections of those cables first. If not, proceed with the following steps.

**Step 8** Mount back the communication terminal cover by referring to [7.9.1 Communication Terminal Cover](#).

**Step 9** Pull gently the cables backward and tighten the swivel nut clockwise.

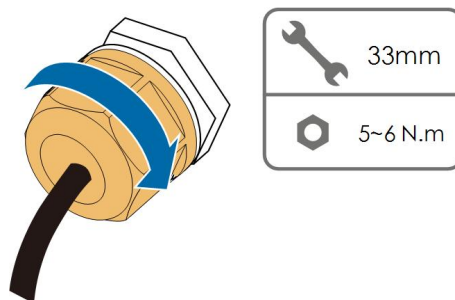

Incorrect cable connection will cause abnormalities in the power flow diagram. In this case, please check the wiring.

--End

### 7.9.3.3.2 Wiring Steps for Network Cable

**Step 1** Remove the communication terminal box.

**Step 2** Unscrew the swivel nut on the terminal cover and select an appropriate sealing ring according to the outer diameter of the cable.

**Step 3** Pass the network cable through the magnetic ring and wrap it around the magnetic ring one time.

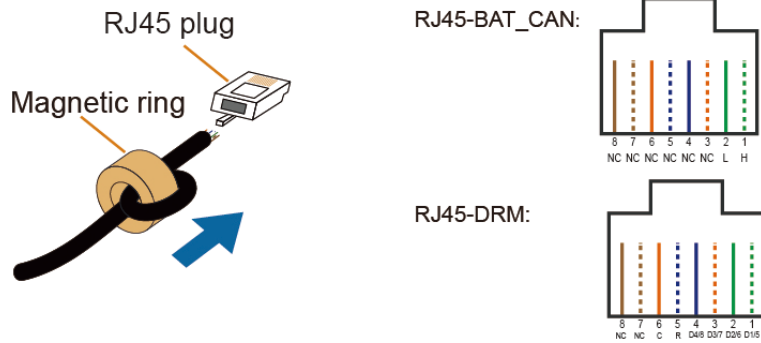

**i** The network cable used for connecting the DRM and BAT\_CAN requires a shielded layer. It is recommended that the outer diameter of the configured shielded network cable be less than 8 mm.

**Step 4** Lead the cable through the swivel nut, the sealing ring, and then the opening on the terminal cover.

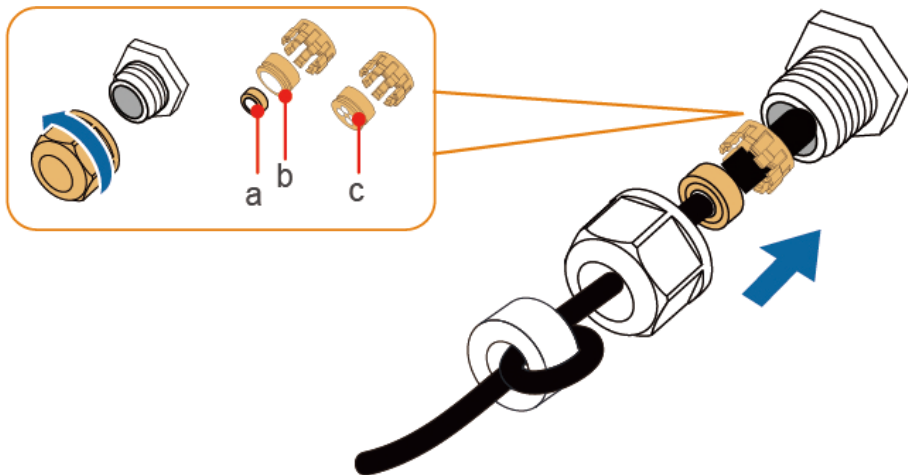

Cable Diameter D (mm)	Sealing Ring
4.5–6	c
6–12	a+b
12–18	b

**Step 5** Insert the RJ45 plug into the corresponding terminal block socket.

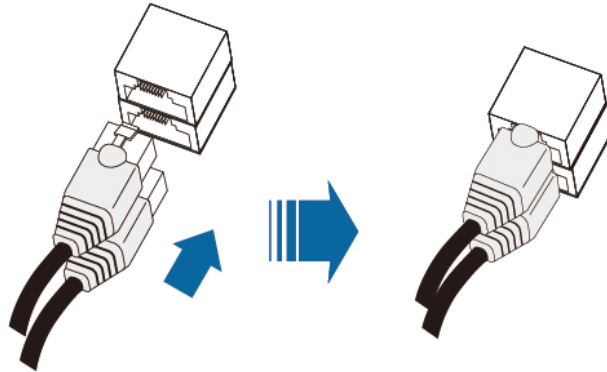

**Step 6** Mount back the communication terminal cover by referring to [7.9.1 Communication Terminal Cover](#).

**Step 7** Pull gently the cables backward and tighten the swivel nut clockwise.

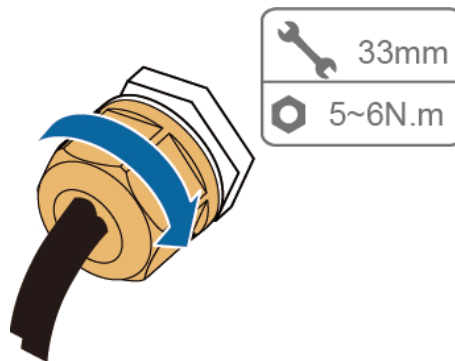

Incorrect cable connection will cause abnormalities in the power flow diagram. In this case, please check the wiring.

--End

#### 7.9.4 Dry Contact Function

The communication wiring area is provided with dry contacts for fault output and emergency stop, as shown in the figure below.

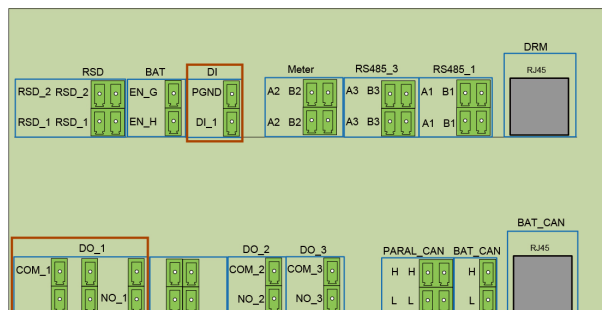

**DO Terminals (Fault Output Dry Contact)**

The relay can be configured as a fault alarm output. The user can configure it as a normally open (COM\_1&NO\_1) .

Use LED indicators or other equipment to indicate whether the inverter is in the faulty state. The following Figures show the typical applications of normal open contact :

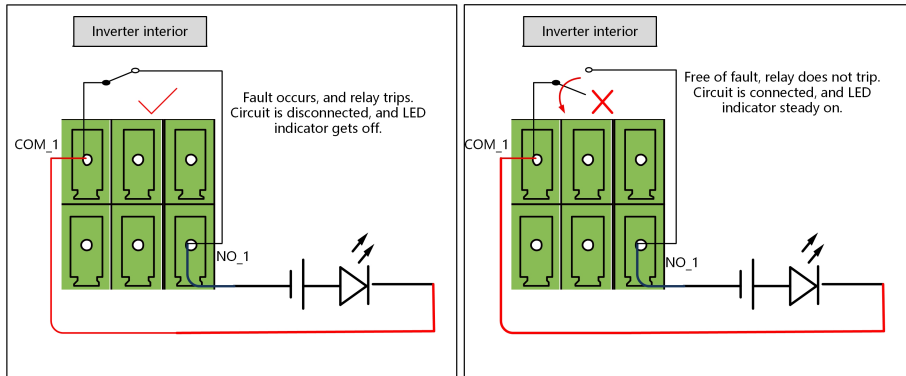

**Figure 7-5** Normally Open Contact

Devices connected to the relay must meet the relevant requirements:

AC side Requirements	DC side Requirements
Max. voltage: 230 Vac	Max. voltage: 24 Vdc
Max. current: 3 A	Max. current: 3 A

### DI Terminals (Emergency Stop Dry Contact)

The dry contacts can be configured for emergency stop contact.

When the RSD\_1 contact and RSD\_2 contact are shorted by external controlled switch (The external switch can be configured as normally open contact or normally closed contact), the inverter will immediately stop.



The dry contacts only support passive switch signal input.

The following figure shows the typical application of local stop dry contact.

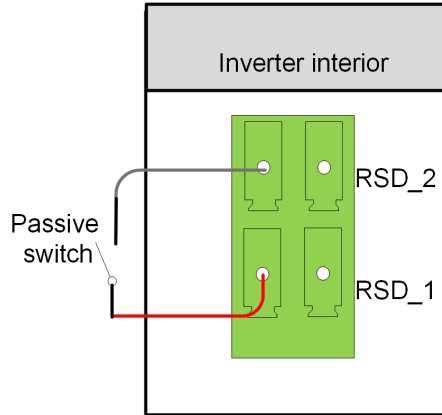

**Figure 7-6** Local stop contact

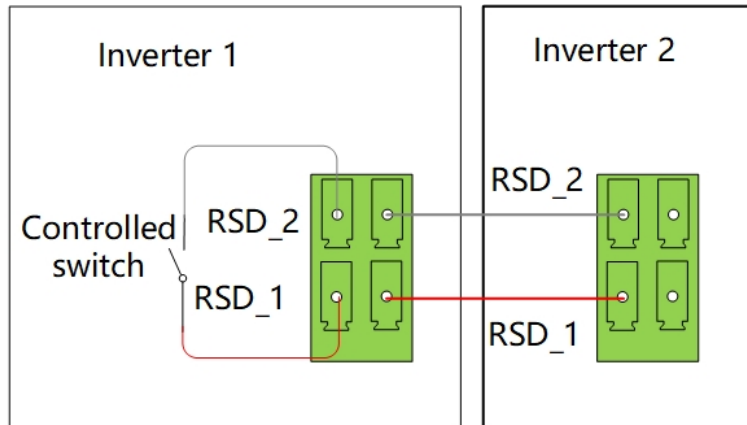

**Figure 7-7** Daisy chain topology

When wiring the DI dry contacts, ensure that the maximum wiring distance meet the requirements in [12.2 Wiring Distance of DI Dry Contact](#).

#### 7.9.4.1 Wiring Steps



The wiring of dry contacts is the same as that of the RS485 terminal block.

Please refer to the wiring instructions in [7.9.3.3.1 Wiring Steps for Shielded Twisted Pair](#).

#### 7.9.5 DRM Connection

DRM and Ripple Control support only one function at the same time.

##### DRM

The inverter supports the demand response modes as specified in the standard AS/NZS 4777. The inverter has integrated a terminal block for connecting to a DRED.

After the connection, the DRED assert DRMs by shorting together terminals as specified in the table below.

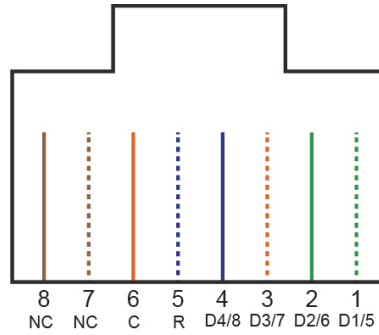
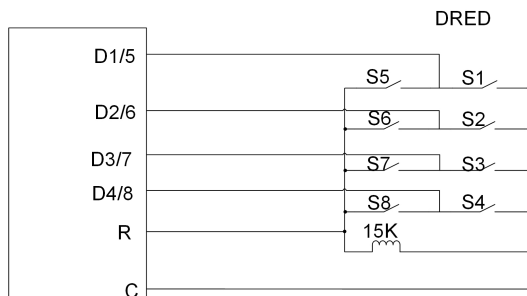

**Table 7-7** Method of Asserting DRMs

Mode	Asserted by Shorting Terminals
DRM0	R & C
DRM1	D1/5 & C
DRM2	D2/6 & C
DRM3	D3/7 & C
DRM4	D4/8 & C
DRM5	D1/5 & R
DRM6	D2/6 & R
DRM7	D3/7 & R
DRM8	D4/8 & R

The inverter only supports DRM0.

Wiring between the inverter and the DRED is as follows.



The switches that need to be closed in the state of DRM0 ~ DRM8 are shown in the table below.

Demand Response Mode	Operational Instruction	Switch state
DRM0	O10	Close S1 and S5
DRM1	O11	Close S1
DRM2	O12	Close S2
DRM3	O13	Close S3
DRM4	O14	Close S4
DRM5	O15	Close S5
DRM6	O16	Close S6
DRM7	O17	Close S7
DRM8	O18	Close S8

### NS Protection

NS Protection is only applicable to German. NS Protection is triggered by rising signal from Grid Supervision Relais (Ziehl, bender, ABB, Phoenix Contact) at SH125CX COM2-socket within 100 internal / 200ms overall, due to VDE 4105 for installed systems with together >30kVA.

The following table provides the overview of cable connection and parameter setting requirements in different scenarios.

Scenario	Cable Connection	Parameter Setting
Multiple SHCXs + Logger	Necessary to every SHCX	Local: iSolarCloud App Remote: iSolarCloud App/Web



In multiple-inverter system, each inverter must be directly connected to the same NS protection relay.

The DRM1/5 and R terminals on inverter COM2/3 port are used for NS protection.

For a system with single inverter, connect DRM1/5 and R to external NS Protection Relay to realize NS protection, as shown in the following figure.

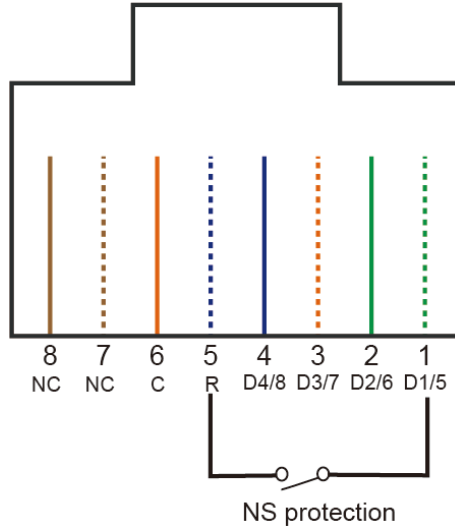

**Ripple Control Receiver**

The grid company uses the Ripple Control Receiver to convert the grid dispatching signal and send it as a dry contact signal.

Wiring of the ripple control receiver dry contact cables is shown in the figure below:

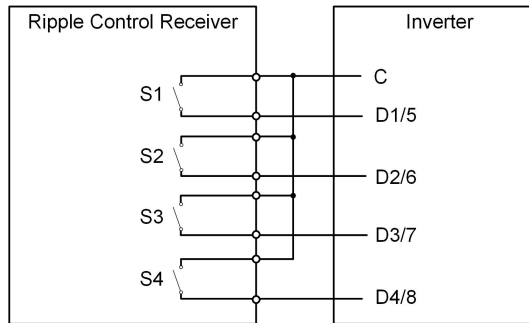

**Table 7-8** Method of Asserting DI Mode

S 1	S 2	S 3	S 4	Switch Operation on External RCR	Output power (in % of the Rated AC output power)
0	0	0	0	None	100 % (configurable according to need)
1	0	0	0	Close S1	100 %
0	1	0	0	Close S2	60 %
0	0	1	0	Close S3	30 %
1	1	0	0	Close S1 and S2	0 % (disconnect from grid)

### 7.9.6 DSP Communication Connection

During off-grid parallel operation, multiple inverters can be connected via CAN.

RSD		BAT		DI	Meter		RS485_3		RS485_1		DRM
RSD_2	RSD_2	EN_G	PGND		A2	B2	A3	B3	A1	B1	
RSD_1	RSD_1	EN_H	DI_1		A2	B2	A3	B3	A1	B1	
DO_1 <sup>φ</sup>					DO_2	DO_3	PARAL_CAN		BAT_CAN		
COM_1				COM_2	COM_3	H	H	H			
		NO_1		NO_2	NO_3	L	L	L			

The connection diagram example is as follows.

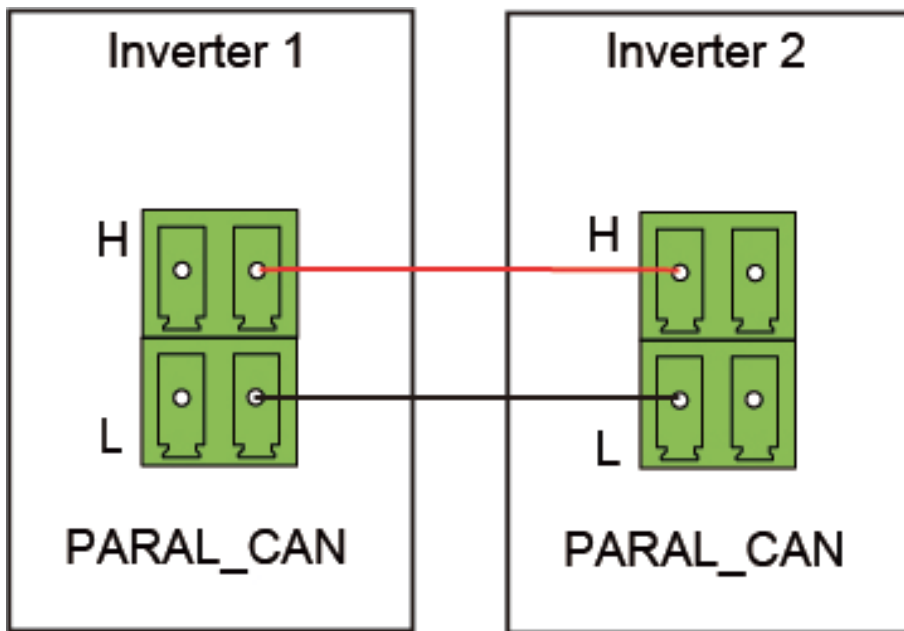

### 7.9.7 Battery Communication Connection



This is the description of connection to the battery communication cable on the hybrid inverter side. Consult the manual of the battery for the description of connection on the battery side.

#### Pin terminal connection

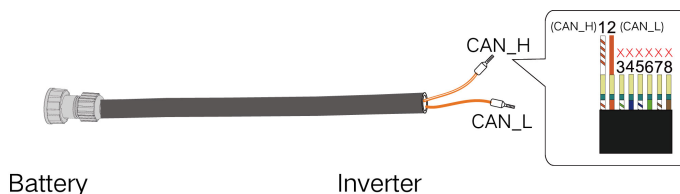

Plug the wires into the H, L terminal of the COM2/3 terminal.

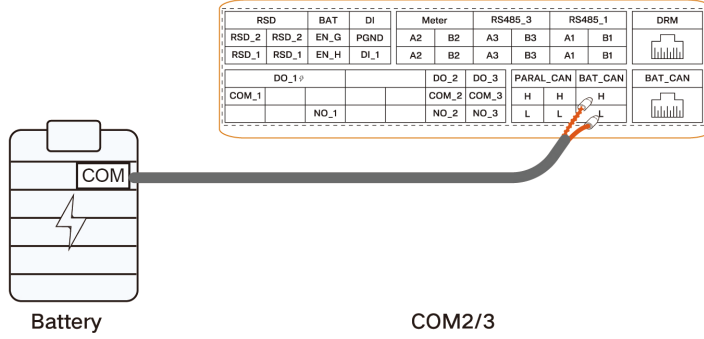
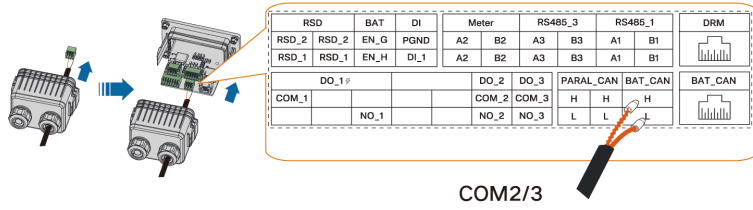

**RJ45 connection**



Battery

Inverter

Plug the wires into the BMS\_CAN terminal of the COM2/3 terminal.

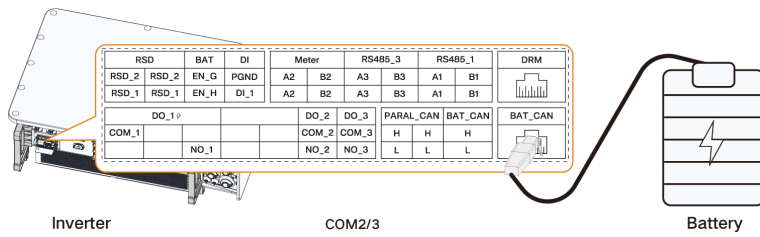

**NOTICE**

**Before connecting the communication cable, ensure the wire sequence is consistent.**

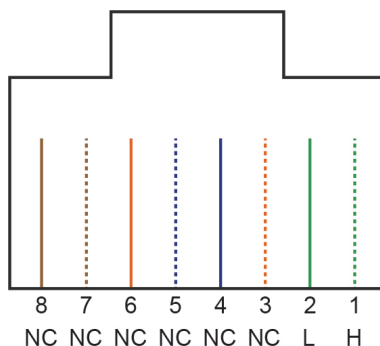

## 7.10 Install Protective Cover (Optional for SH110CX)

After completing all inverter cable connections, install the protective cover for SH110CX. Prepare the following materials before installation.

Item	Quantity	Specification	Source
countersunk screw	6	M4x8	Delivery scope
hexagon bolt assembly	8	M4x10	Delivery scope
hexagon bolt assembly	1	M6x12	Delivery scope
Hole-drilling template	1	-	Delivery scope
Fully-threaded bolt assembly (bracket-mounting) / Expansion bolt assembly (wall-mounting)	7	M10×45/M10x95 (recommend)	Self-prepared

**Step 1** Mark the holes for drilling on the wall by Hole-drilling template.

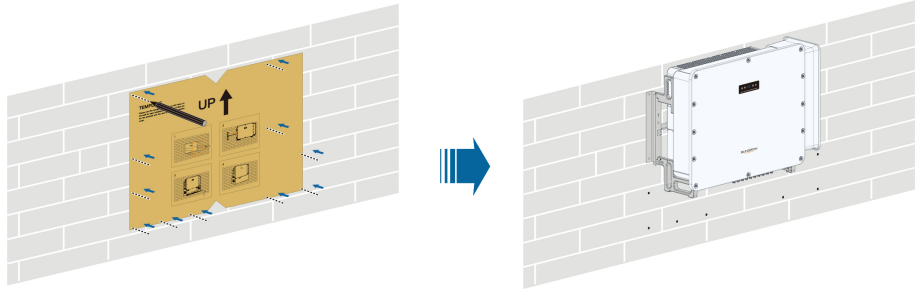

**Step 2** The protective cover consists of a top panel, front panel, bottom panel, left panel, and right panel.

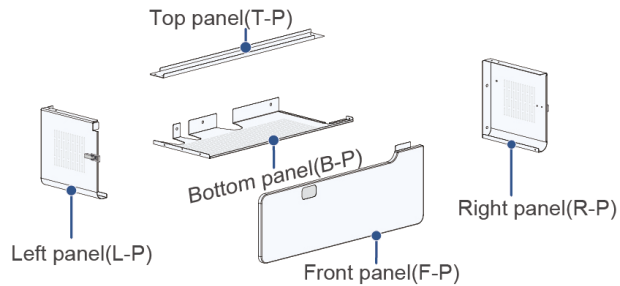

**Step 3** Insert the bottom panel into the left and right panels and tighten the screws.

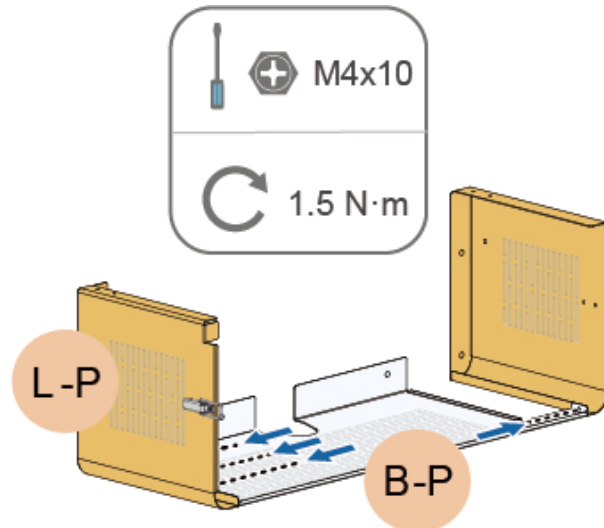

**Step 4** After completing the inverter's electrical cable connections, position the protective cover assembly at the bottom of the inverter. Ensure the threaded holes on the panel fasteners align with the corresponding holes on the inverter.

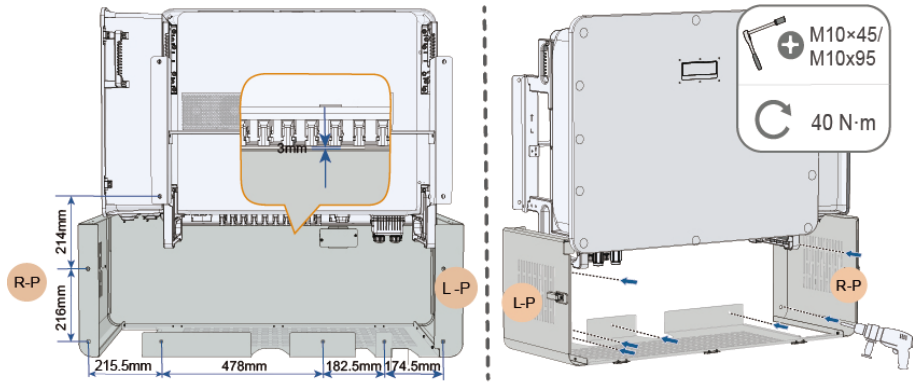

**Step 5** Install the front panel, then tighten the bottom, left, right, and front panels.

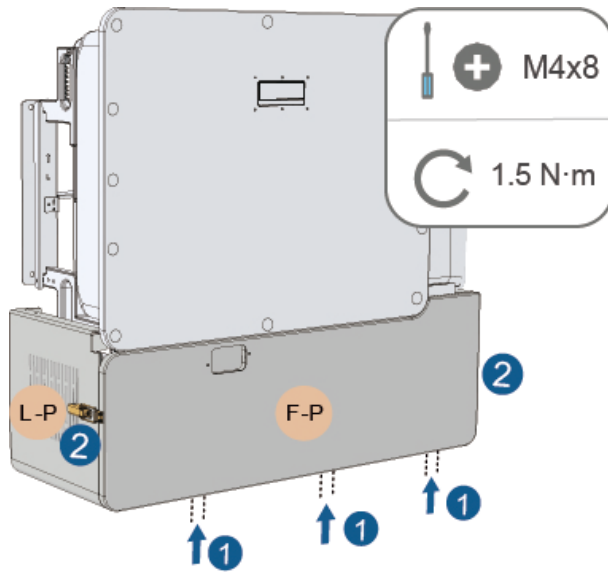

**Step 6** Install and tighten the top panel.

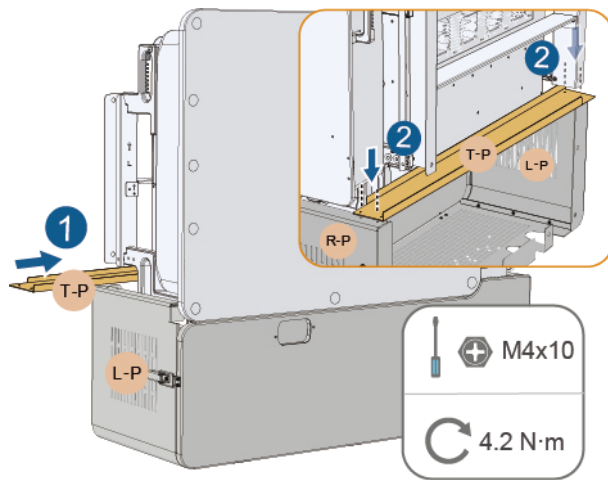

**Step 7** Connect the grounding cable to the right panel.

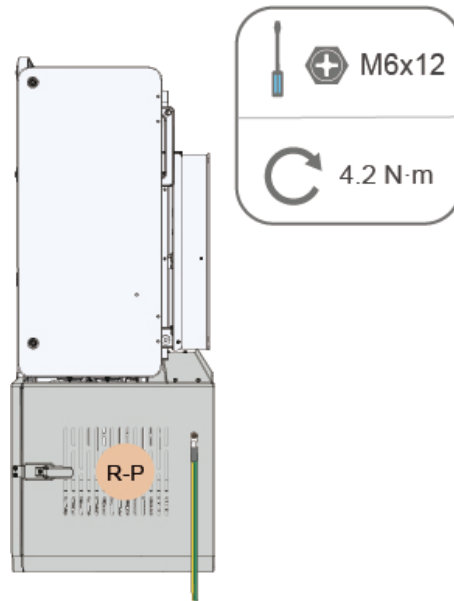

--End



Installing the protective cover may attenuate the wireless communication signal, which can subsequently reduce the effective communication range of the wireless module.

## 8 iSolarCloud App

### 8.1 About iSolarCloud

The iSolarCloud App is a mobile application used for power plant management. The App provides plant operation analysis service and enables intelligent mobile O&M. It is designed with functions such as plant operation data display, rapid plant access, parameter setting, quick fault location and notification, and power yield and revenue analysis. With iSolarCloud, convenient and efficient end-to-end plant O&M is allowed.

#### Connection Methods

Users can log in to the App via remote connection or local access for plant monitoring.

#### Login by Establishing a Direct Connection (Local)

Establish communication between the mobile phone and the inverter's built-in Bluetooth module to enable mobile maintenance of the inverter. After logging into the App, users can check the information about and set parameters for the inverter.



Direct Login (Local)



Login via Bluetooth connection is applicable only for SUNGROW inverters with built-in Bluetooth modules. Please consult your retailer/installer about whether the inverter is equipped with a Bluetooth module.

#### Login with an Account (Remote)

Establish communication between the logger and the router or base station to enable data exchange between the inverter and the cloud server. After logging into the App, users can

check the inverter data or send commands to control the inverter on the App. (The inverter can only connect to the cloud through a logger, which supports wireless communication via Wi-Fi or 4G.)



Login Via Account and Password (Remote)

## 8.2 Install iSolarCloud

### Prerequisite

This section introduces how to download and install the iSolarCloud App.

### Procedure

**Step 1** Search for **iSolarCloud** in App Store, Google Play or other App stores, or scan the QR code below with a mobile phone and download the App by following the onscreen instructions.



**Step 2** Tap the downloaded installation package and follow the onscreen instructions to complete the installation. The icon of iSolarCloud will then appear on the screen.



--End

## 8.3 User Roles

After logging into the iSolarCloud App with different roles, users will have varying levels of access to device operations. The default accounts and passwords corresponding to different user roles can be found in [iSolarCloud App User Manual Device Commissioning \(V2.1.6.20250218or Later\)](#) > **Device Connection** > **Device Connection via WLAN** > **Identity Verification**.

For account security purposes, please refer to the **Identity Verification** section to change your password promptly after logging into the iSolarCloud App.

## 8.4 Device Commissioning

For device commissioning operations, please refer to the **Device Commissioning** in the [iSolarCloud App User Manual](#). Alternatively, you can scan the QR code below to access the **Device Commissioning** section of the manual.



# 9 Commissioning

## 9.1 Inspection Before Commissioning

Check the following items before starting the inverter:

- All equipment has been reliably installed.
- DC switch(es) and AC circuit breaker are in the "OFF" position.
- The ground cable is properly and reliably connected.
- The AC cable is properly and reliably connected.
- The DC cable is properly and reliably connected.
- The communication cable is properly and reliably connected.
- The unused terminals are sealed.
- No foreign items, such as tools, are left on the top of the machine or in the junction box (if there is).
- The AC circuit breaker is selected in accordance with the requirements of this manual and local standards.
- All warning signs & labels are intact and legible.



If the inverter has been mounted but remains non-operational for more than three months, it must be inspected and tested by qualified personnel before being put into operation.

## 9.2 Commissioning Steps

If the requirements for the above-mentioned items are all met, proceed as follows to start up the inverter for the first time.

**Step 1** Power on the battery circuit breaker.

**Step 2** Rotate the DC switch to "ON". The DC switch is integrated in the inverter.

**Step 3** Turn on the AC circuit breaker between the inverter and the grid.

**Step 4** Observe the status of the inverter LED indicator to ensure the inverter is working normally.

**Step 5** Install the iSolarCloud App.

**Step 6** The first time the inverter is connected to the grid, complete the protection parameter initialization on the iSolarCloud App. If, with sufficient light, the grid conditions meet the grid connection requirements, the inverter will work normally.

**Step 7** The home page is automatically displayed when the setting is completed.

**⚠ WARNING**

**Do not close the DC switch when the inverter is in the grid-connected state. Otherwise, the inverter may be damaged due to absence of an insulation resistance test, and the loss caused therefrom will not be covered by warranty.**

--End



- Wait 5 minutes after completing the previous step before proceeding to the next one.
- Strictly follow the preceding sequence. Otherwise, the product may be damaged, and the loss caused is not covered by the warranty.
- Before closing the AC circuit breaker between the inverter and the power grid, use a multimeter that is set to the AC gear to ensure that the AC voltage is within the specified range. Otherwise, the inverter may be damaged.

# 10 Inverter Decommissioning

## 10.1 Shut Down the Inverter

### Prerequisite

#### CAUTION

##### **Burn hazard!**

**There is a risk of burns even after the inverter has been shut down. Wait for the inverter to cool down. Then, perform operations on the inverter wearing safety gloves.**

Normally, the inverter does not need to be shut down. However, for maintenance or repair, shutdown is required. Follow the steps below to disconnect the inverter from both AC and DC power. Failure to do so may result in personal injury or equipment damage.

- Step 1** Turn off the external AC circuit breaker and prevent it from being accidentally turned back on.
  - Step 2** Turn off the external DC circuit breaker (external battery circuit breaker), then rotate the inverter's DC switch to the "OFF" position.
  - Step 3** Wait at least 15 minutes for the internal capacitors to fully discharge.
  - Step 4** Test the DC cables using a current clamp and ensure they are current-free.
- End

## 10.2 Dismantle the Inverter

### Prerequisite

#### CAUTION

##### **Danger of burns and electric shocks!**

**After the inverter is powered off for 15 minutes, measure the voltage and current using proper instruments. Perform operation and maintenance of the inverter wearing proper protective equipment after confirming that there is no voltage or current present.**



- Before dismantling the inverter, disconnect both AC and DC connections.
- If there are more than two layers of inverter DC terminals, dismantle the outer DC connectors before dismantling the inner ones.
- If the original packing materials are available, put the inverter inside them and then seal them using adhesive tape. If the original packing materials are not available, put the inverter inside a cardboard box suitable for the weight and size of this inverter and seal it properly.

**Step 1** Refer to [7 Electrical Connection](#) to disconnect all cables of inverter in reverse steps. To disconnect the DC connectors, use a connector wrench to loosen their locking elements, and then fit waterproof plugs.

**Step 2** Refer to [6 Mechanical Mounting](#) to dismantle the inverter in reverse steps.

**Step 3** If necessary, remove the wall-mounting bracket from the wall.

**Step 4** If the inverter will be used again in the future, please refer to [5.3 Inverter Storage](#) for a proper conservation.

--End

### 10.3 Dispose of Inverter

The user is responsible for disposing of the inverter.

#### **WARNING**

**Please scrap the product in accordance with relevant local regulations and standards to avoid property damages or personal injuries.**

#### **NOTICE**

**Some parts of the inverter may cause environmental pollution. Please dispose of them in accordance with the disposal regulations for electronic waste applicable at the installation site.**

# 11 Troubleshooting and Maintenance

## 11.1 Troubleshooting

When an alarm occurs, the alarm information can be viewed through the App.

Alarm ID and corrective measures are as follows:

Alarm ID	Alarm Name	Corrective Measures
002, 003, 014, 015	Grid Overvoltage	Generally, the inverter will be reconnected to the grid after the grid returns to normal. If the fault occurs repeatedly: 1. Measure the actual grid voltage, and contact the local electric power company for solutions if the grid voltage is higher than the set value. 2. Check whether the protection parameters are appropriately set via the App or the LCD. Modify the overvoltage protection values with the consent of the local electric power operator. 3. If the fault still exists, contact SUNGROW.
004, 005	Grid Undervoltage	Generally, the inverter will be reconnected to the grid after the grid recovers. If the alarm occurs frequently: 1. Measure the grid voltage, and contact the local utility grid company for solutions if the grid voltage is below the specified value. 2. Check, through the App, whether the protection parameters are appropriately set. 3. Check whether the AC cable is firmly in place. 4. If the alarm persists, contact SUNGROW.
008	Grid Overfrequency	Generally, the inverter will be reconnected to the grid after the grid recovers. If the alarm occurs frequently: 1. Measure the grid frequency, and contact the local utility grid company for solutions if the grid frequency is beyond the specified range. 2. Check, through the App, whether the protection parameters are appropriately set.
009	Grid Underfrequency	Generally, the inverter will be reconnected to the grid after the grid recovers. If the alarm occurs frequently: 1. Measure the grid frequency, and contact the local utility grid company for solutions if the grid frequency is beyond the specified range. 2. Check, through the App, whether the protection parameters are appropriately set.

Alarm ID	Alarm Name	Corrective Measures
		3. If the alarm persists, contact SUNGROW.
010	Grid Power Outage	<p>Generally, the inverter will be reconnected to the grid after the grid recovers. If the alarm occurs frequently:</p> <ol style="list-style-type: none"> <li>1. Check whether the grid supplies power reliably.</li> <li>2. Check whether the AC cable is firmly in place.</li> <li>3. Check whether the AC cable is correctly connected (whether the live wire and the N wire are in correct place).</li> <li>4. Check whether the AC switch or circuit breaker is disconnected.</li> <li>5. If the alarm persists, contact SUNGROW.</li> </ol>
012	Excessive Leakage Current	<ol style="list-style-type: none"> <li>1. The alarm can be caused by poor sunlight or damp environment, and the inverter will be reconnected to the grid after the environment is improved.</li> <li>2. If the environment is normal, check whether the AC and DC cables are well insulated.</li> <li>3. If the alarm persists, contact SUNGROW.</li> </ol>
013	Grid Abnormal	<p>Generally, the inverter will be reconnected to the grid after the grid recovers. If the alarm occurs frequently:</p> <ol style="list-style-type: none"> <li>1. Measure the grid frequency, and contact the local utility grid company for solutions if the grid frequency exceeds the specified value.</li> <li>2. If the alarm persists, contact SUNGROW.</li> </ol>
017	Grid Voltage Unbalance	<p>Generally, the inverter will be reconnected to the grid after the grid returns to normal. If the fault occurs repeatedly:</p> <ol style="list-style-type: none"> <li>1. Measure the actual grid voltage. If grid phase voltages differ greatly, contact the electric power company for solutions.</li> <li>2. If the voltage difference between phases is within the permissible range of the local power company, modify the grid voltage imbalance parameter through the App.</li> <li>3. If the fault still exists, contact SUNGROW.</li> </ol>

Alarm ID	Alarm Name	Corrective Measures
037	High Ambient Temperature	<p>Generally, the inverter will resume operation when the internal or module temperature returns to normal. If the fault persists:</p> <ol style="list-style-type: none"> <li>1. Check whether the ambient temperature of the inverter is too high;</li> <li>2. Check whether the inverter is in a well-ventilated place;</li> <li>3. Check whether the inverter is exposed to direct sunlight. Shield it if so;</li> <li>4. Check whether the fan is running properly. Replace the fan if not;</li> <li>5. If the fault still exists, contact SUNGROW.</li> </ol>
039	Low System Insulation Resistance	<p>Wait for the inverter to return to normal. If the fault occurs repeatedly:</p> <ol style="list-style-type: none"> <li>1. Check whether the ISO resistance protection value is excessively high via the app, and ensure that it complies with the local regulations.</li> <li>2. Check the resistance to ground of the string and DC cable. Take corrective measures in case of short circuit or damaged insulation layer.</li> <li>3. If the cable is normal and the fault occurs on rainy days, check it again when the weather turns fine.</li> <li>4. If there are batteries, check whether battery cables are damaged and whether terminals are loose or in poor contact. If so, replace the damaged cable and secure terminals to ensure a reliable connection.</li> <li>5. If the fault still exists, contact SUNGROW.</li> </ol>
106	Grounding Cable Fault	<ol style="list-style-type: none"> <li>1. Check whether the AC cable is correctly connected.</li> <li>2. Check whether the insulation between the ground cable and the live wire is normal.</li> <li>3. If the fault still exists, contact SUNGROW.</li> </ol>
051	Off-grid Load Overpower	<ol style="list-style-type: none"> <li>1. Reduce the power of loads connected at the off-grid port, or remove some loads.</li> <li>2. If the alarm persists, contact SUNGROW.</li> </ol>
714	BMS Communication Fault	<ol style="list-style-type: none"> <li>1. Check whether the communication cable and the terminals are abnormal. If so, correct them to ensure reliable connection.</li> </ol>

Alarm ID	Alarm Name	Corrective Measures
		<ol style="list-style-type: none"> <li>2. Reconnect the communication cable of the meter.</li> <li>3. If the fault still exists, contact SUNGROW.</li> </ol>
932–935, 937, 939	Battery Alarm	<p>Generally, the battery can automatically recover. In case the alarm persist for a long time:</p> <ol style="list-style-type: none"> <li>1. If the alarm is caused by ambient temperature, such as over temperature alarm or low temperature alarm, take measures to change the ambient temperature, such as improving heat dissipation conditions.</li> <li>2. If the fault persists, contact battery manufacturer.</li> </ol>
703, 711, 712, 715, 732–736, 739, 832– 833, 835– 837	Battery Abnormal	<ol style="list-style-type: none"> <li>1. In case of abnormal battery voltage, check whether the battery power cable connection is abnormal (reverse connection, loose, etc.). If so, connect the battery power cable correctly.</li> <li>2. Check whether the battery real-time voltage is abnormal if the battery power cable is correctly connected. If so, contact the battery manufacturer. If not, contact SUNGROW.</li> <li>3. In case of abnormal battery temperature, take measures to change the ambient temperature, such as improving heat dissipation conditions.</li> <li>4. If the fault persists, contact battery manufacturer.</li> </ol>
502-504, 507, 508, 510, 513, 516–518, 994, 996	System Alarm	<ol style="list-style-type: none"> <li>1. The inverter can continue running.</li> <li>2. Check whether the related wiring and terminal are abnormal, check whether there are any foreign materials or other environmental abnormalities, and take corresponding corrective measures when necessary.</li> <li>3. If the alarm persists, please contact SUNGROW.</li> </ol>
514	Meter Communication Abnormal Alarm	<ol style="list-style-type: none"> <li>1. Check whether the communication cable and the terminals are abnormal. If so, correct them to ensure reliable connection.</li> <li>2. Reconnect the communication cable of the meter.</li> <li>3. If the alarm still exists, contact SUNGROW.</li> </ol>
006, 007, 011, 019, 021, 025,	System Fault	<ol style="list-style-type: none"> <li>1. Wait for the inverter to return to normal.</li> <li>2. Disconnect the AC and DC switches, and disconnect the battery side switches if there are</li> </ol>

Alarm ID	Alarm Name	Corrective Measures
038, 040– 042, 048– 050, 052– 054, 056, 064–067, 100–102, 105, 107, 113, 117, 200–205, 300, 303– 305, 308– 316, 320, 600, 601, 605, 608, 612, 616, 620, 624, 995		batteries. Close the AC and DC switches in turn 15 minutes later and restart the system. 3. If the fault still exists, contact SUNGROW.
75	Parallel Communication Alarm	<ol style="list-style-type: none"> <li>1. Wait for the fault to clear automatically.</li> <li>2. Verify that the parallel connection parameter settings are correct.</li> <li>3. Inspect the communication wiring between the master and slaves for unconnected, loosely connected, or damaged cables.</li> <li>4. If the fault occurs repeatedly, contact SUNGROW Customer Service.</li> </ol>
90	Inverter Parallel Synchronous Signal Abnormal	<ol style="list-style-type: none"> <li>1. Check the master and slave settings. Verify that one inverter is set as the master and the remaining inverters are set as slaves. The number of the master and slaves should match the actual configuration, and the slave IDs should be set in sequential order.</li> <li>2. Check whether the parallel communication wiring is correct, including the wiring of CAN2H/ CAN2L in COM1 ports between different devices.</li> <li>3. Check whether a matching termination resistor is added to the last inverter. The 120Ω resistor (included in the accessories) should be properly connected between CAN2H and CAN2L.</li> </ol>

Alarm ID	Alarm Name	Corrective Measures
213	Parallel Inverter Grid Port Wiring Fault	Check whether the phase sequence of wiring at the GRID terminal is consistent across the master and slaves in the system.
214	Parallel Inverter Load Port Wiring Fault	Check whether the phase sequence of wiring at the LOAD terminal is consistent across the master and slaves in the system.
329	AC port wiring abnormal or terminal abnormal	<ol style="list-style-type: none"> <li>1. Inspect the AC port wiring.</li> <li>2. Power off and restart the inverter.</li> <li>3. If the fault does not arise for the aforementioned reason and still cannot be resolved, contact SUNGROW Customer Service.</li> </ol>
514	Meter Communication Abnormal Alarm	<ol style="list-style-type: none"> <li>1. Check whether the meter is connected.</li> <li>2. Check whether the connection of the meter communication cable is correct and secure.</li> <li>3. If the fault does not arise for the aforementioned reason and still cannot be resolved, please contact SUNGROW Customer Service.</li> </ol>
714	BMS Communication Fault	Check whether the communication cables are correctly connected. If the fault persists, please contact SUNGROW Customer Service.
995	Backup Port Short Circuit	<ol style="list-style-type: none"> <li>1. Shut down the inverter.</li> <li>2. Use a multimeter to measure the resistance between every two phase lines and check if they conform to the actual load in the family.</li> <li>3. Check AC cable connection to the Load port.</li> </ol>
69, 635-636	DC Switch Trip Alarm	<ol style="list-style-type: none"> <li>1. The machine can continue running when only DC Switch 1 or DC Switch 2 trips.</li> <li>2. Check the alarm-related cables and terminals for any anomalies, check for any environmental anomalies such as foreign objects, and clear the anomalies.</li> <li>3. If the alarm is not caused by the foregoing reasons and persists, please contact Sungrow Customer Service.</li> </ol> <p>635 and 636 indicate DC Switch 1 and DC Switch 2 tripping, respectively.</p>
304	EPS Relay Fault	<ol style="list-style-type: none"> <li>1. Try powering off and restarting the inverter.</li> </ol>

Alarm ID	Alarm Name	Corrective Measures
		2. If the fault is not caused by the foregoing reason and persists, please contact Sungrow Customer Service.
71, 72	System alarm	It is recommended to manually shut down the unit in case of lightning protection failure and contact Sungrow after-sales professionals for inspection and maintenance.
99	Balanced Bridge Overtemperature	1. Power off and restart the inverter. 2. Check whether the wiring of the temperature sensor inside the device is loose or damaged.
414	Grid Port Overload	Reduce the load power at the backup port or multi-function port, turn off some loads, and click "Clear port overload fault".
415	Backup Port Overload	Reduce the load power at the backup port, turn off some loads, and click "Clear port overload fault".



Contact the installer if the measures listed in the "Troubleshooting Method" column have been taken but the problem persists. Contact SUNGROW if the installer fails to solve the problem.

## 11.2 Maintenance

### 11.2.1 Maintenance Precautions

#### **DANGER**

When maintaining the product, it is strictly prohibited to open the product if there is an odor or smoke or if the product appearance is abnormal. If there is no odor, smoke or obvious abnormal appearance, repair or restart the inverter according to the alarm corrective measures. Avoid standing directly in front of the inverter during maintenance.

**Risk of personal injury or equipment damage due to improper servicing!**

- Be sure to use specialized insulated tools when performing high-voltage operations.
- Before maintenance, disconnect the AC circuit breaker on the grid side and then the DC switch. If a fault that may cause personal injury or device damage is found before maintenance, disconnect the AC circuit breaker and wait until the night before operating the DC switch. Otherwise, a fire inside the product or an explosion may occur, causing personal injuries.
- Wait 15 minutes after the inverter is powered off, then test the voltage and current using specialized measurement instruments. Maintenance and operation must only be performed by qualified personnel who wear protective equipment after confirming that no voltage or current is present.
- Even if the inverter has stopped running, it may still be hot and cause burns. Perform operations on the inverter wearing protective gloves after it cools down.

#### **CAUTION**

To prevent misuse or accidents caused by unrelated personnel: please set up highly visible warning signs around the inverter or fence off a warning zone.

#### **NOTICE**

Restart the inverter only after removing the fault that impairs safety performance. As the inverter contains no component parts that can be maintained, never open the enclosure or replace any internal components.

To minimize the risk of electric shocks, do not perform maintenance operations that are not specified in this manual. If necessary, contact SUNGROW for maintenance. Losses arising from failure to observe this instruction will not be covered by warranty.

**NOTICE**

Touching the PCB or other static-sensitive components may cause damage to the device.

- Do not touch the circuit board unless it is necessary.
- Observe the provisions for protection against electrostatic discharge and wear anti-static wrist straps.

**11.2.2 Routine Maintenance**

The maintenance item and period of the device are listed in the table below.

Inspection Item	Inspection Method	Maintenance Period
Device Clean	Check whether the air outlet and heat sink are blocked by dust and other objects. Clean the air outlet and the heat sink if necessary.	Once every six months to a year
Fan	Inspect if there is abnormal noise during operation of the fans. Inspect if there is crack on blades of the fan. If necessary, Replace the fan.	Once a year
Cable inlet design	Check whether the cable inlet hole of the device is fully sealed. If not, fill the crack with fireproof and waterproof materials.	Once a year
Electrical connection	Check whether cables are loose or fall off. Check whether the cable is damaged, especially the part in contact with the metal enclosure.	Once every six months to a year

### 11.2.3 Fan Maintenance

#### **⚠ DANGER**

- **Before maintaining its fans, power off the inverter and disconnect it from all power sources.**
- **Wait 15 minutes after the inverter is powered off, then test the voltage and current using specialized measurement instruments. Maintenance and operation must only be performed by qualified personnel who wear protective equipment after confirming that no voltage or current is present.**
- **Fan maintenance must only be performed by qualified technical persons.**

The inverter is equipped with built-in fans for heat dissipation during operation. If the fans do not operate normally, the inverter may not be cooled down and inverter efficiency may decrease. Therefore, it is necessary to clean dirty fans and replace the broken fans in a timely manner.

Clean and replace the fans as follows:

**Step 1** Stop the inverter, referring to [10.1 Shut Down the Inverter](#).

**Step 2** Loosen the screw on the cover plate for the fans of the inverter.

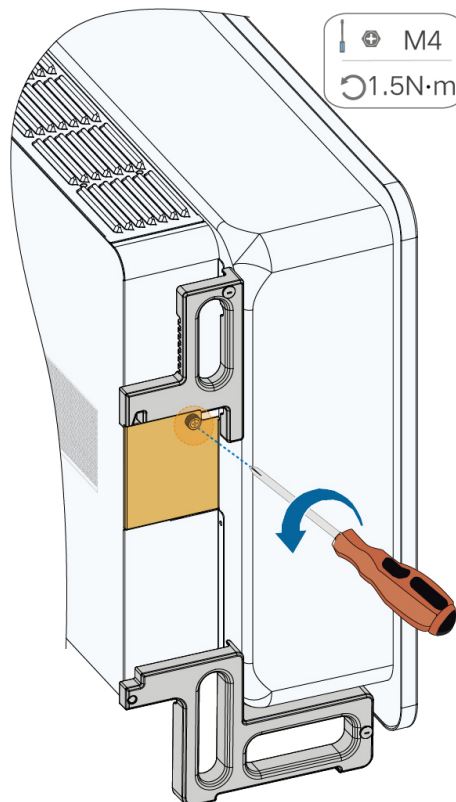

**Step 3** Press the key on the connector to release its locking element, and pull the connector out. Then, loosen the screws on the fan holder.

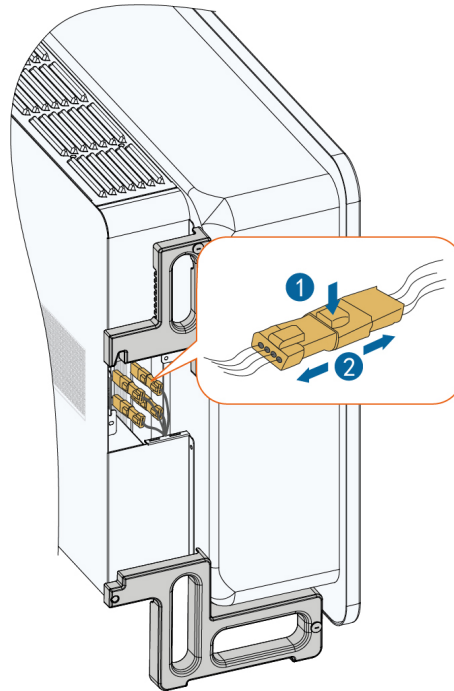

**Step 4** Loosen the screws on the side of the fans.

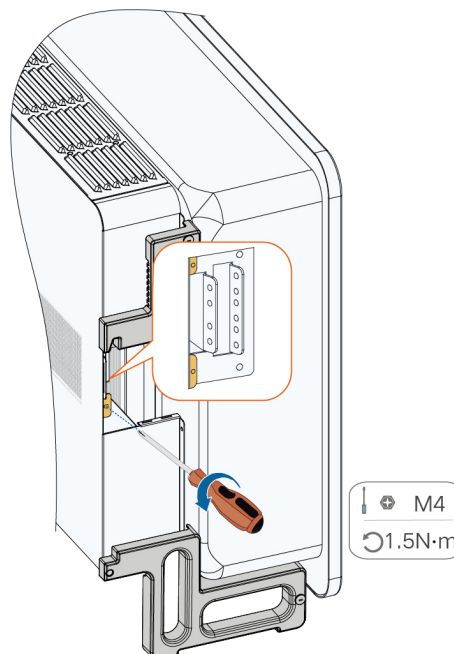

**Step 5** Pull out the fan holder and clean the fans using a soft brush or a vacuum cleaner. Replace the fan if it is damaged.

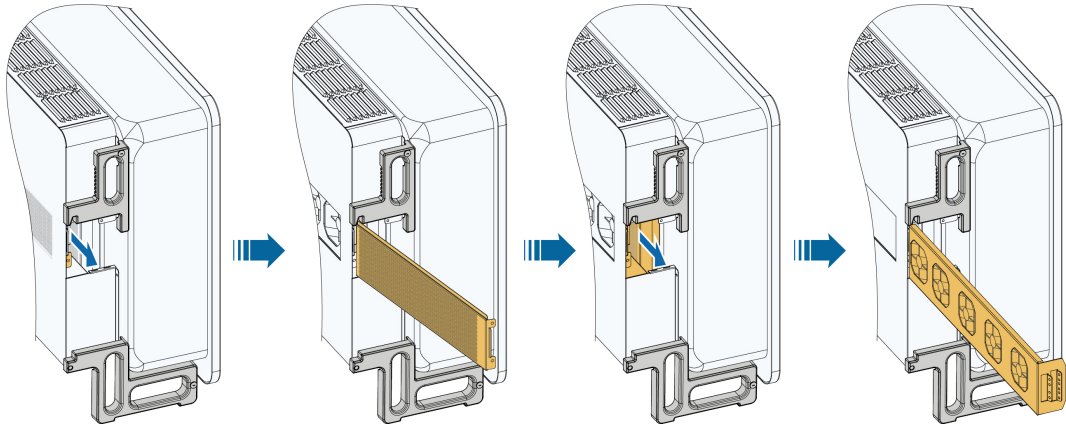

--End

### 11.2.4 Clean Air Outlet

The inverter generates significant heat during operation and therefore uses forced air cooling.

To ensure proper ventilation, regularly inspect the air inlets and outlets to confirm they are clear and unobstructed.

Clean the air inlets and outlets using a soft brush when needed.

After shutting down the inverter, remove the upper inlet grille and the lower outlet grille. Clean the inlet grilles, outlet grilles, and heatsinks with a soft brush, vacuum cleaner, or blower. After cleaning, reinstall all components in the correct order.

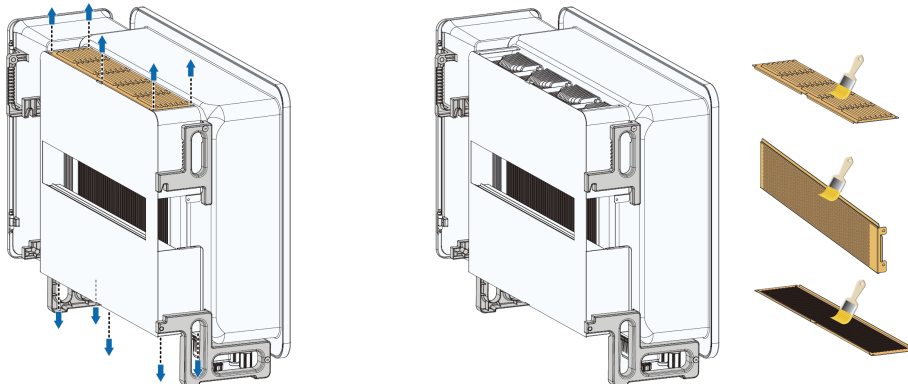

### 11.2.5 DC Switch Maintenance

#### Prerequisite



The DC switch is equipped with an automatic disconnection function. When the device detects a major internal fault in the inverter (such as overvoltage, overcurrent, overtemperature, etc.), it triggers the DC switch to automatically disconnect for protection.

If the inverter's DC switch has tripped to the "OFF" position, please follow the procedure below.

**Step 1** Check the fault information on the App or Web system of iSolarCloud.

**Step 2** In case of a fault inside the inverter, please contact SUNGROW for technical support.

**--End**

# 12 Appendix

## 12.1 Technical Data

Parameter	SH110CX	SH125CX
<b>Input (DC)</b>		
Max. PV input power	220 kWp	250 kWp
Max. PV input voltage*	1100 V	1100 V
Min. PV input voltage / Startup input voltage	180 V / 200 V	180 V / 200 V
Rated PV input voltage	600 V	600 V
MPPT voltage range	180 V - 1000 V	180 V - 1000 V
MPP voltage range for rated power	550V - 880V	550V - 880V
No. of independent MPP inputs	10	10
No. of PV strings per MPPT	2	2
Max. PV input current	40 A * 10	40 A * 10
Max. DC short-circuit current	50 A * 10	50 A * 10
Max. current for DC connector	30 A	30 A
<b>Battery data</b>		
Battery type	Lithium-ion battery	Lithium-ion battery
Battery Voltage Range**	129 V - 880 V	129 V - 880 V
Communication	CAN	CAN
Max. charge / discharge current***	200 A / 200 A	200 A / 200 A

Parameter	SH110CX	SH125CX
Max. charge / discharge power	110kW / 110kW	125kW / 125kW
<b>Input and output (AC)</b>		
Max. AC power from grid****	160 kVA	160 kVA @ 230 V
Rated AC output power	110 kW	125 kW
Max. AC output apparent power	110 kVA	125 kVA
Max. AC output current	158.8 A	189.9 A
Rated AC output current	158.8 A	180.4 A
Rated AC voltage	3 / N / PE, 220 V/ 380 V, 230 V/ 400 V	3 / N / PE, 220 V / 380 V, 230 V/ 400 V
AC voltage range	270V - 480V	270V - 480V
Rated grid frequency	50 Hz / 60 Hz	50 Hz / 60 Hz
Grid frequency range	45 Hz – 55 Hz / 55 Hz – 65 Hz	45 Hz – 55 Hz / 55 Hz – 65 Hz
Harmonic (THD)	< 3 % (at 400V AC voltage and rated power)	< 3 % (at 400V AC voltage and rated power)
Power factor at rated power / Adjustable power factor	> 0.99 / 0.8 leading – 0.8 lagging	> 0.99 / 0.8 leading – 0.8 lagging
Feed-in phases / AC connection	3 / 3 - N - PE	3 / 3 - N - PE
<b>Backup data</b>		
Rated voltage	3 / N / PE, 220 V/ 380 V, 230 V/ 400 V	3 / N / PE, 220 / 380 V, 230 / 400 V
Rated frequency	50Hz/60Hz	50Hz/60Hz
THDV ( @Linear load )	< 2 % (at rated power)	< 2 % (at rated power)

Parameter	SH110CX	SH125CX
Backup switch time of single inverter	≤10ms	≤10ms
Rated output power	110 kW	125 kW
Peak load power	1.5 times of rated power, 10s	1.5 times of rated power, 10s
<b>Efficiency</b>		
Max. efficiency / European efficiency	98.5 % / 98.2 %	98.6 % / 98.3 %
<b>Protection &amp; function</b>		
Grid monitoring	Yes	Yes
DC reverse polarity protection	Yes	Yes
AC short-circuit protection	Yes	Yes
Leakage current protection	Yes	Yes
DC switch	Yes	Yes
Ground fault monitoring	Yes	Yes
PV string current monitoring	Yes	Yes
Arc fault circuit interrupter (AFCI)	Yes	Yes
Surge protection	DC Type I+II / AC Type II	DC Type I+II / AC Type II
PID zero	Yes	Yes
Battery input reverse polarity protection	Yes	Yes
<b>General data</b>		
Topology	Transformerless	Transformerless
Degree of protection	IP66	IP66

Parameter	SH110CX	SH125CX
Dimensions (W * H * D)	1095 mm * 795 mm * 360 mm	1095 mm * 795 mm * 360 mm
Protective class	Protective class I	Protective class I
Overtoltage category	III[AC]; II[PV] [BATTARY]	III[AC]; II[PV] [BATTARY]
Active anti-islanding method	Frequency shift	Frequency shift
Weight	≤ 128 kg	≤ 128 kg
Mounting method	Wall-mounting bracket	Wall-mounting bracket
Operating ambient temperature range	- 30 °C – 60 °C	- 30 °C – 60 °C
Allowable relative humidity range (non-condensing)	0 – 100 %	0 – 100 %
Corrosion	C5	C5
Cooling method	Smart forced air cooling	Smart forced air cooling
Max. operating altitude	3000 m	3000 m
Noise (Typical)	≤ 65 dB ( A )	≤ 65 dB ( A )
Grid compliance	IEC 62109-1/-2, IEC 62477-1, IEC 62920, AS/NZS 4777.2:2020, IEC 61683, IEC 62116, IEC 61727, IEC 60068, IEC 61000-6-3, IEC 63027	IEC 62109-1/-2, IEC 62477-1, IEC 62920, EN 55011, IEC 63027, VDE-AR-N 4105, VDEAR- N 4110, NRS 097-2-1, UNE 207002, UNE 207001, NTS 2.1, CEI 0-16, CEI 0-21, EN 50549, EN 50530, IEC 61683, IEC 62116, IEC 61727, IEC 60068, IEC 61000-6-3, IEC 63027
<b>Interface</b>		
Display	LED, Bluetooth + APP	LED, Bluetooth + APP
Communication with battery	CAN	CAN

Parameter	SH110CX	SH125CX
Communication with Logger	RS485	RS485
Communication between Logger and iSolarCloud	4G / WLAN / Ethernet	4G (Optional)/WLAN / Ethernet
DI / DO	DI * 2 / DO * 3	DI * 2 / DO * 3
DC connection type	MC4 (Max. 6 mm <sup>2</sup> )	MC4 (Max. 6 mm <sup>2</sup> )
AC connection type	OT / DT terminal (Max. 300 mm <sup>2</sup> )	OT / DT terminal (Max. 300 mm <sup>2</sup> )
Country of manufacture	China	China

\* Input voltage exceeding the MPPT operating voltage range triggers inverter protection.

\*\* Minimum battery voltage for black-start : 270 V.

\*\*\* Depending on the connected battery.

\*\*\*\*Max. AC power from grid would be 110kVA for SH110CX and 125kVA for SH125CX if inverter works without backup loads.

## 12.2 Wiring Distance of DI Dry Contact

The maximum wiring distance for DI dry contact terminals must meet the requirements listed below. The wiring distance L is the total length of all DI signal cables.

$$L = 2 \sum_{k=1}^n L_k$$

$L_k$  is the one-way cable length between the DI dry contact terminal of the k-th inverter and the corresponding terminal of the previous device.

**Table 12-1** Maximum Wiring Distance for DI Dry Contact Terminals

Number of Inverters	Maximum Wiring Distance (unit:m)	
	16 AWG / 1.31 mm <sup>2</sup>	17 AWG / 1.026 mm <sup>2</sup>
1	13030	10552
2	6515	5276
3	4343	3517

Number of Inverters	Maximum Wiring Distance (unit:m)	
	16 AWG / 1.31 mm <sup>2</sup>	17 AWG / 1.026 mm <sup>2</sup>
4	3258	2638
5	2606	2110
6	2172	1759
7	1861	1507
8	1629	1319
9	1448	1172
10	1303	1055
11	1185	959
12	1086	879
13	1002	812
14	931	754
15	869	703
16	814	660
17	766	621
18	724	586
19	686	555
20	652	528
21	620	502
22	592	480
23	567	459
24	543	440

**NOTICE**

If the selected cable gauge is not listed above, for a single inverter, ensure the Input terminal wiring impedance is < 300 Ω. For multiple inverters connected in daisy-chain topology, ensure node impedance is < (300 Ω / number of inverters).

## 12.3 Quality Assurance

When product faults occur during the warranty period, SUNGROW will provide free service or replace the product with a new one.

The software security update period for this product aligns with the warranty period. During the warranty, security patches or updates will be provided if any vulnerabilities or compatibility issues are identified.

### Evidence

During the warranty period, the customer shall provide the product purchase invoice and date. In addition, the trademark on the product shall be undamaged and legible. Otherwise, SUNGROW has the right to refuse to honor the quality guarantee.

### Conditions

- After replacement, unqualified products shall be processed by SUNGROW.
- The customer shall give SUNGROW a reasonable period to repair the faulty device.

### Exclusion of Liability

In the following circumstances, SUNGROW has the right to refuse to honor the quality guarantee:

- The free warranty period for the whole machine/components has expired.
- The device is damaged during transport.
- The device is incorrectly installed, refitted, or used.
- The device operates in harsh conditions beyond those described in this manual.
- The fault or damage is caused by installation, repairs, modification, or disassembly performed by a service provider or personnel not from SUNGROW.
- The fault or damage is caused by the use of non-standard or non-SUNGROW components or software.
- The installation and use range are beyond stipulations of relevant international standards.
- The damage is caused by unexpected natural factors.

For faulty products in any of above cases, if the customer requests maintenance, paid maintenance service may be provided based on the judgment of SUNGROW.



Product data such as product dimensions are subject to change without prior notice. The latest documentation from SUNGROW should take precedence in case of any deviation.

## 12.4 Contact Information

In case of questions about this product, please contact us. We need the following information to provide you the best assistance:

- Model of the device
- Serial number of the device
- Fault code/name
- Brief description of the problem

For detailed contact information, please visit: <https://en.SUNGROWpower.com/contactUS>

**SUNGROW**

Sungrow Power Supply Co., Ltd.

[www.sungrowpower.com](http://www.sungrowpower.com)