

User Manual

Data Logger

Logger4000



All Rights Reserved

All Rights Reserved

No part of this document can be reproduced in any form or by any means without the prior written permission of Sungrow Power Supply Co., Ltd (hereinafter "SUNGROW").

Trademark

SUNGROW and other Sungrow trademarks used in this manual are owned by SUNGROW. All other trademarks or registered trademarks mentioned in this manual are owned by their respective owners.

Software Licenses

- It is prohibited to use data contained in firmware or software developed by SUNGROW, in part or in full, for commercial purposes by any means.
- It is prohibited to perform reverse engineering, cracking, or any other operations that compromise the original program design of the software developed by SUNGROW.

About This Manual

The manual mainly contains the product information, as well as guidelines for installation, operation and maintenance. Readers can get additional information at www.sungrowpower.com or on the webpage of the respective component manufacturer.

Validity

This manual is valid for the following models:

- Logger4000

Target Group

This manual is intended for qualified technicians who are responsible for installation, operation, and maintenance of the product, and users who need to check inverter parameters.

The product must only be installed by qualified technicians. The qualified technical technician must:

- Have electronic, electrical wiring, and mechanical expertise, and be familiar with electrical and mechanical schematics.
- Have received professional training related to the installation and commissioning of electrical equipment.
- Be able to respond quickly and effectively to dangers or emergencies that may occur during installation and commissioning.
- Be familiar with local standards and relevant safety regulations of electrical systems.
- Read this manual thoroughly and understand the safety instructions related to operations.

How to Use This Manual

Read through this manual carefully before using the product, and keep it properly in an easy-to-reach place.

The information in this manual is subject to ongoing updates and revisions. Although efforts have been made to ensure accuracy, there might be slight variations or errors compared to the actual product. Please refer to the actual product purchased, and the latest manual can be obtained from support.sungrowpower.com or sales channels.

Symbols

This manual contains important safety instructions, which are highlighted with the following symbols, to ensure personal and property safety during usage, or to help optimize the product performance in an efficient way.

Symbols used in this manual are listed below. Please review carefully for better use of this manual.

 DANGER

Indicates high-risk potential hazards that, if not avoided, will result in death or serious injury.

 WARNING

Indicates moderate-risk potential hazards that, if not avoided, may lead to death or serious injury.

 CAUTION

Indicates low-risk potential hazards that, if not avoided, may lead to minor or moderate injury.

NOTICE

Indicates potential risks that, if not avoided, may lead to device malfunction or financial losses.



"NOTE" indicates additional information, important content, or helpful tips that may solve problems or save time.

Contents

All Rights Reserved.....	I
About This Manual.....	II
1 Safety Instructions.....	1
2 Product Description.....	3
2.1 Function Description.....	3
2.2 Networking Application.....	4
2.3 Product Introduction.....	7
3 Unpacking and Storage.....	9
3.1 Scope of Delivery.....	9
3.2 Identifying the Data Logger.....	10
3.3 Checking upon Receiving.....	10
3.4 Storage.....	11
4 Mechanical Installation.....	12
4.1 Installation Location Selection.....	12
4.2 Installation Tools.....	12
4.3 Mounting the Data Logger.....	14
4.3.1 Wall-Mounted Installation.....	14
4.3.2 Rack-Mounted Installation.....	15
5 Electrical Connection.....	17
5.1 Safety Instructions.....	17
5.2 Port Introduction.....	17
5.3 Wiring Overview.....	20
5.4 Connecting to the Inverter.....	20
5.4.1 Connecting to the Device with RS485 Port.....	20
5.4.2 Connecting to the Inverter with MPLC Port.....	23
5.5 Connecting to the Meteo Station.....	25
5.6 Connecting to the Energy Meter.....	26
5.6.1 RS485 Cable Connection.....	26
5.6.2 Ethernet Cable Connection.....	27
5.7 Wiring of DI Signal.....	27
5.8 Wiring of DO Signal.....	28
5.9 Wiring of AI Signal.....	29
5.10 Wiring of PT Signal.....	31
5.11 Connecting to the Remote Monitoring Device.....	32

5.12 Connecting to the AC Power Supply.....	33
5.13 Connecting to the DC Power Supply.....	34
5.14 Earthing Connection.....	34
6 Commissioning	36
6.1 Inspection before Commissioning.....	36
6.2 Commissioning Step.....	36
7 Web Main Interface	39
7.1 Log In to the Web UI.....	39
7.2 Modifying Password.....	41
7.3 Web UI Overview.....	41
7.3.1 Web Main Interface.....	41
7.3.2 Running Requirements.....	42
7.3.3 Operation Procedure.....	43
7.4 Overview.....	43
7.4.1 General Information.....	43
7.4.2 Current Alarms.....	44
7.5 Device Monitoring.....	44
7.5.1 RealTime Values.....	45
7.5.2 DC Info.....	45
7.5.3 Initial Parameter.....	45
7.5.4 Operation Parameters.....	45
7.5.5 System Parameters.....	45
7.5.6 Protection Parameter.....	46
7.5.7 Protection Parameters (Other).....	46
7.5.8 Power Regulation Parameters.....	46
7.5.9 Fault Recording Parameters.....	46
7.5.10 General Parameter.....	46
7.5.11 Device Instruction.....	47
7.5.12 Device Information.....	47
7.5.13 Dispersion Rate Analysis.....	47
7.5.13.1 Enabling Dispersion Rate Diagnosis.....	48
7.5.13.2 Setting Array Parameters.....	48
7.5.13.3 Initiating Dispersion Rate Diagnosis.....	49
7.5.13.4 Viewing Diagnosis Results.....	50
7.6 Device Maintenance.....	52
7.6.1 Device List.....	52
7.6.1.1 Auto Search.....	52
7.6.1.2 Export.....	53
7.6.1.3 Import.....	53
7.6.1.4 Add Device.....	53

7.6.1.5 Edit Device.....	55
7.6.1.6 Delete Device.....	55
7.6.2 Inverter Log.....	55
7.6.3 AFCI Activation.....	56
7.6.4 Fault Recording.....	56
7.6.5 Configuring Bluetooth Pairing for Inverter.....	58
7.6.5.1 Enabling Bluetooth Pairing.....	58
7.6.5.2 Disabling Bluetooth Pairing.....	59
7.6.6 (Optional) Winding Temperature Detection.....	60
7.6.6.1 Viewing Real-time Data.....	60
7.7 History Data.....	63
7.7.1 Log.....	63
7.7.2 Fault Record.....	64
7.7.3 History Curve.....	64
7.7.4 Syslog Logs.....	65
7.8 System.....	65
7.8.1 Run Information.....	65
7.8.2 System Maintenance.....	66
7.8.2.1 Log Export.....	66
7.8.2.2 Rebooting.....	66
7.8.2.3 One-click Migration.....	66
7.8.2.4 Backup and Restoration.....	66
7.8.2.5 Attribute Management.....	67
7.8.2.6 HTTPS Certificate Import.....	67
7.8.2.7 Network Security Mode Configuration.....	68
7.8.2.8 Import Public Key.....	68
7.8.3 Remote Maintenance.....	68
7.8.4 Message Export.....	69
7.8.5 System Time.....	70
7.8.6 Forward iSolarCloud service settings.....	71
7.8.7 IEC104.....	72
7.8.7.1 White List Settings.....	72
7.8.7.2 Generate Point Table.....	72
7.8.7.3 Import IEC104 Forwarding Point Table.....	72
7.8.7.4 Export IEC104 Forwarding Point Table.....	73
7.8.7.5 Set IEC104 Dispatch Mode.....	73
7.8.8 MODBUS.....	73
7.8.8.1 Server Mode.....	74
7.8.8.2 RTU Mode.....	74
7.8.8.3 Modbus TCP Fast Dispatch.....	74

7.8.8.4 Regular Modbus TCP Dispatch Modes.....	75
7.8.9 Configure Third-Party Cloud Forwarding Service.....	76
7.8.10 Configure GOOSE Forwarding Service.....	76
7.8.11 Certificate Security Maintenance.....	77
7.8.12 Setting MMS Forwarding Service.....	79
7.8.13 Port Parameter.....	79
7.8.13.1 RS485.....	79
7.8.13.2 Ethernet.....	80
7.8.13.3 AI.....	80
7.8.13.4 Digital Input(DI).....	81
7.8.13.5 DO.....	81
7.8.14 MPLC (Broadband PLC).....	81
7.8.14.1 MPLC Auto Frequency Hopping.....	82
7.8.14.2 One-Click MPLC Diagnosis.....	83
7.8.15 More.....	83
7.8.16 Viewing the Firmware Version.....	83
8 Updating.....	85
8.1 Updating SUNGROW Inverters or the Slave Node of PLC.....	85
8.2 Updating the Data Logger.....	86
8.3 Update PLC master node.....	86
9 Grid Dispatching.....	88
9.1 Options for Power Control Method.....	88
9.2 Selecting Power Control Mode.....	88
9.3 Settings for Active Power Control.....	89
9.3.1 Remote Power Control.....	90
9.3.1.1 Open-Loop Control.....	90
9.3.1.2 Closed-Loop control.....	91
9.3.1.3 Setting Fallback Value in Case of Communication Failure.....	91
9.3.2 Locally Regulating Active Power.....	93
9.3.2.1 Open-Loop Control.....	93
9.3.2.2 Closed-Loop control.....	93
9.3.2.3 Configuring Adjustment Time and Target Values.....	95
9.3.3 Regulating Active Power via Analog Input.....	96
9.3.4 Regulating Active Power via Digital Input(DI).....	97
9.3.5 Disabling Active Power Control.....	98
9.3.6 Prohibiting the Inverter from Reducing Power Output.....	98
9.4 Settings for Reactive Power Control.....	98
9.4.1 Remote Power Control.....	98
9.4.2 Local power control.....	99
9.4.3 Regulating Reactive Power via Analog Input.....	100

9.4.4	Regulating Reactive Power via Digital Input(DI).....	101
9.4.5	Regulating Reactive Power via Country Mode.....	101
9.4.6	Disabling Reactive Power Control.....	102
9.4.7	Disabling Reactive Power Output.....	102
9.5	Setting Emergency Stop.....	102
10	User Management.....	104
10.1	Initial Usernames and Passwords.....	104
10.2	Password Management.....	105
10.3	Setting up Administrator Account.....	106
10.4	Creating O&M Users.....	106
10.5	Deleting O&M Users.....	107
10.6	Resetting Account Password.....	107
10.6.1	Resetting O&M Account Password.....	107
10.6.2	Resetting Administrator Account Password.....	108
10.7	Set account protection and session security parameters.....	108
10.8	Enabling the O&M Mode.....	109
10.9	LDAP Management.....	109
10.9.1	System Maintenance.....	110
10.9.1.1	Backup and Restore.....	110
10.9.1.2	Reset All Settings.....	111
10.10	Communication Settings.....	111
10.10.1	iSolarCloud.....	111
10.10.2	Third-Party Cloud.....	111
11	Routine Maintenance.....	112
11.1	Safety Instructions.....	112
11.2	Maintenance List.....	112
12	Troubleshooting.....	114
12.1	Safety Instructions.....	114
12.2	Common Faults and Corrective Measures.....	114
13	FAQ.....	119
14	Appendix A: Technical Data.....	121
15	Appendix B: Related Drawings.....	123
16	Appendix C: General Information.....	124
16.1	Quality Assurance.....	124
16.2	Software Security Update Notes.....	124
16.3	Contact Information.....	124

1 Safety Instructions

When installing, commissioning, operating, and maintaining the product, strictly observe relevant safety instructions. Improper use or misoperation may result in:

- Injury or death to the operator or a third party.
- Damage to the product or the property of the operator or a third party.



- The safety instructions in this manual are only supplements and cannot cover all the precautions that should be followed. Perform operations considering actual on-site conditions.
- SUNGROW shall not be held liable for any damage caused by violation of general safety operation requirements, general safety standards, or any safety instruction in this manual.
- When installing, operating, and maintaining the device, comply with local laws and regulations. The safety precautions in this manual are only supplements to local laws and regulations.



WARNING

Only professional electricians or qualified personnel can operate and wire the product.

Warning Label

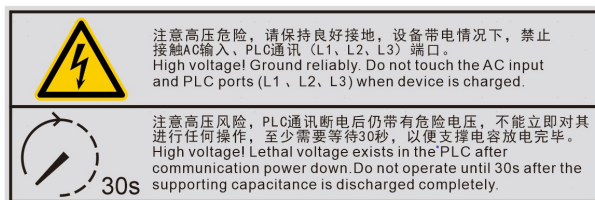
Warning label on enclosure of the Data Logger is as follows:



Symbol	Explanation
	High voltage inside. Risk of electrical shock hazard when it is touched.
	This symbol indicates a protective ground terminal which needs to be firmly grounded to ensure the safety of operators.

Symbol	Explanation
	Do not to touch energized components within 30 seconds after disconnecting the power.

Before Installation

NOTICE

After receiving the product, please check if there is damage caused during transport. Contact SUNGROW or the forwarding company once any problem is found.

The related operators must be familiar with the safety instructions in this manual and other safety regulations about the installation, operation and maintenance of the product.

Follow the instructions in the manual to perform handling, installation, and operation maintenance to ensure the safe and proper use of the product.

During Installation

NOTICE

This product can only be used for purposes specified in this manual. Unauthorized alternations or use of parts and components not sold or recommended by SUNGROW may result in fires, electric shocks, and other hazards.

NOTICE

Disconnect all electrical connection and the upstream input switch before installation, and ensure the device is voltage-free.

NOTICE

Disconnect all electrical connections and the upstream input switch and make sure the device is voltage-free.

Maintenance and Replacement

WARNING

Repair of the device can only be performed by the service department of SUNGROW or professionally qualified personnel.

Users are forbidden from performing repair and maintenance or replacing modules by themselves. Otherwise, it may cause severe personal injuries or property damages.

NOTICE

Never replace the internal components of the device without authorization. SUNGROW shall not be held liable for any possible damage caused by ignorance of this warning.

2 Product Description

2.1 Function Description

The Data Logger is equipped with the following functions:

Support of Device Connection

The Data Logger can be connected to devices in the PV system via an RS485 bus, and it can be also connected to SUNGROW string inverter equipped with the PLC communication function through the PLC cable. The Data Logger can store and process device information as well as convert data communication protocol.

Management of Communication Device

The Data Logger can centrally manage devices connected to it, including parameter setting, firmware upgrade, etc, which makes onsite maintenance more convenient.

Configuration through Web Interface

Users can set system time, network, serial port, etc., and maintain the protocol point table through the embedded Web interface of the Data Logger.

Network Port Configuration

There are five Ethernet ports (namely, ETH1 to ETH5) with the data exchange function on the Data Logger, three Ethernet ports, and two fast scheduling ports. It can be connected to SCADA or insight northward and to third-party devices southward.

Data Forwarding Function

The Data Logger can forward the collected data to iSolarInsight or iSolarCloud.



- The data forwarding function of the Data Logger is disabled by default. Prior to activation, the user must provide explicit consent with full awareness and establish a secure connection to the public network through encrypted authentication. Remote access is only valid after authorization, and all operations are logged for audit and traceability purposes.
- iSolarCloud is not applicable to North America.

Protocol Conversion Service

The Data Logger provides protocol conversion service, including converting Modbus RTU to IEC104, MQTT, ModbusTCP, etc.

Grid Dispatch

The Data Logger can receive and execute power dispatch instructions transmitted from the grid operator via the customer's local SCADA system

Local Power Control

The Data Logger can receive and perform local dispatching instructions, including delivering fixed value, energy meter closed-loop dispatching, etc.

Fast Dispatch

The Data Logger can accept and execute fast active and reactive dispatching instructions to achieve reactive power control within 30ms.

IV Curve Online Diagnosis

The Data Logger can perform I-V curve scanning on inverters developed by SUNGROW, and users can view scanning result via iSolarCloud, Insight or iSolarSuite. For detailed description of the I-V curve scanning, refer to the manual of iSolarCloud, Insight or iSolarSuite.

Built-in MPLC

The Data Logger has a built-in MPLC-H (Broadband Power Line Carrier Communication), which can be directly connected to the string inverter with MPLC function produced by SUNGROW.

2.2 Networking Application

The Data Logger can be applied to various networking scenarios. It can be connected to the inverter, transformer, Meteo Station, and energy meter in the PV system via RS485 bus, or connected to SUNGROW string inverter equipped with MPLC communication function through MPLC bus.

- The Data Logger can transmit the collected device data to the SCADA plant controller, such as Insight and SCADA, through the core switch.
- The Data Logger can also transmit the collected device data directly to iSolarCloud through the 4G router.

Connected to SCADA plant controller through a core switch

The following figures shows how the Data Logger is connected to the Insight or SCADA through a core switch.

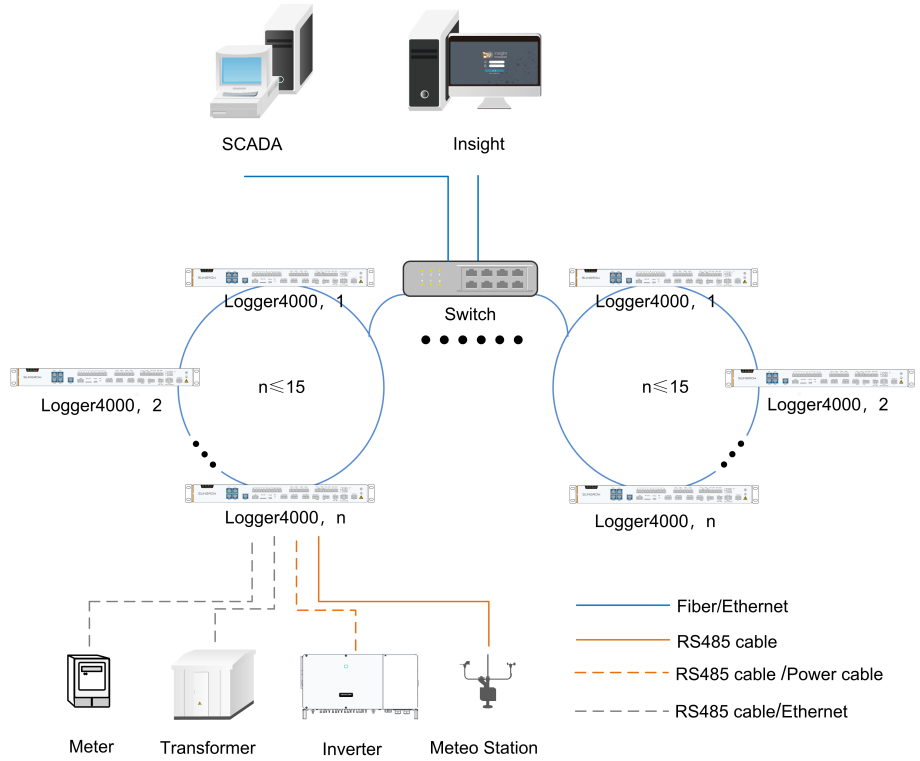

Figure 2-1 Ring networking

When the ring networking is used, a maximum of 15 Data Loggers can be connected to a ring network.

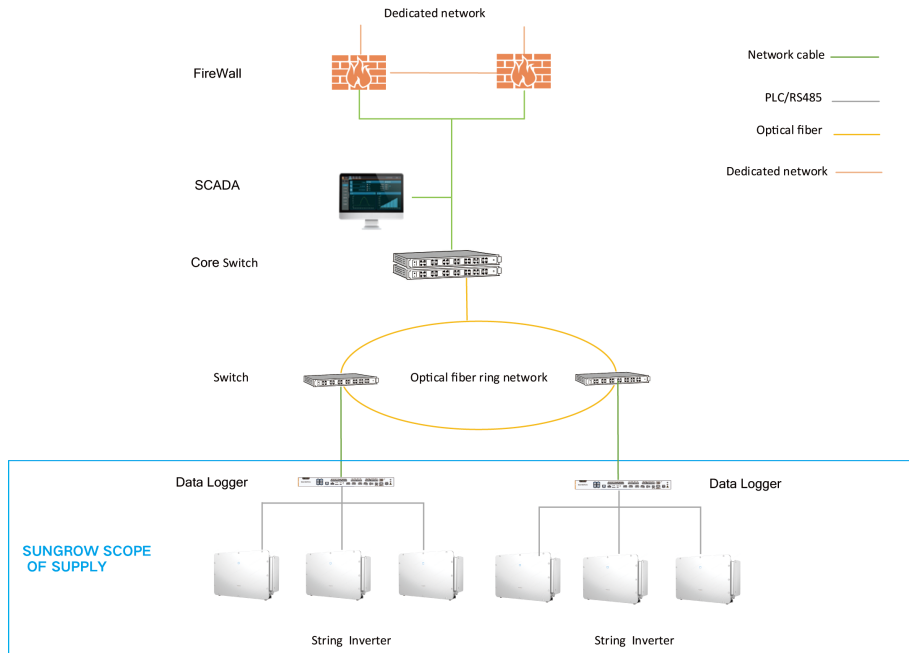
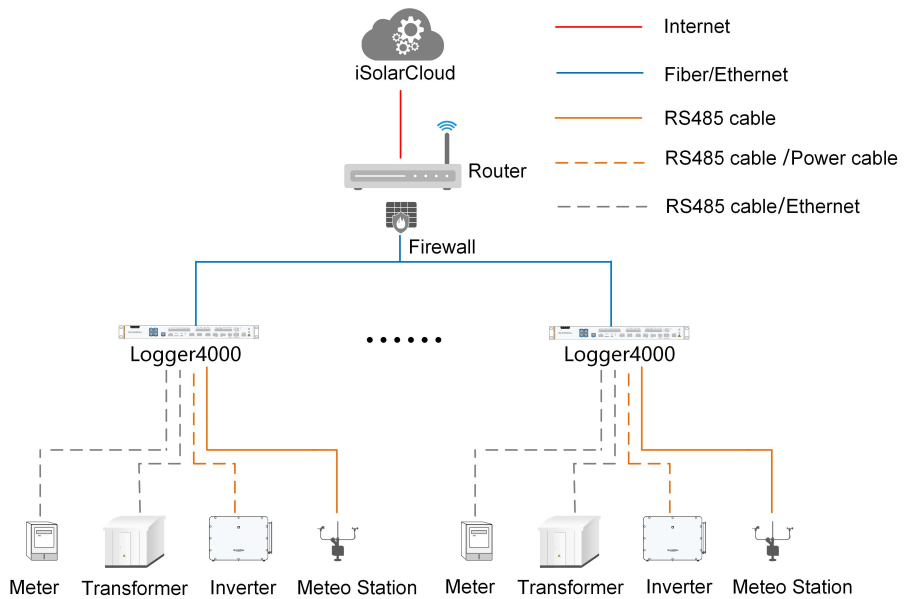

Figure 2-2 Star networking

Connected to iSolarCloud through a Router

As shown in the figure below, the Data Logger can be directly connected to the iSolarCloud through a router.



i The router and firewall are not included in the scope of delivery and need to be prepared by the customer.

2.3 Product Introduction

Appearance

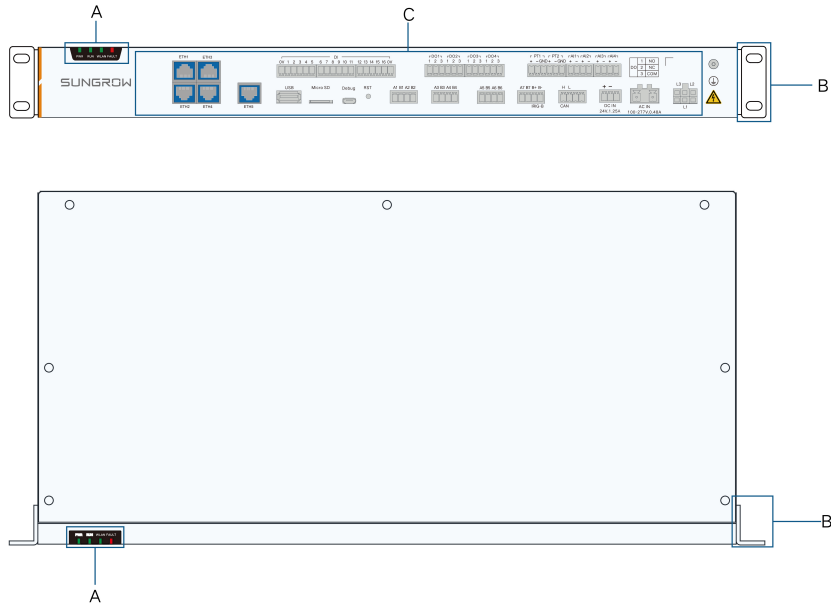

Item	Description
A	Indicators
B	Mounting ear
C	Wiring area

Indicators

Indicators	Name	Status	Status Description
PWR	Power indicators	Steady on (Red)	Normal power supply
		Off	Abnormal power supply
RUN	Running indicator	Blinking	Running normally
		Off/On	Abnormal operation
WLAN	WLAN indicator	Off	No WLAN function

Indicators	Name	Status	Status Description
FAULT	Fault indicator	Steady on (Red)	There is an alarm or fault in the connected inverter.
		Off	The connected inverter is free from faults.

Dimensions

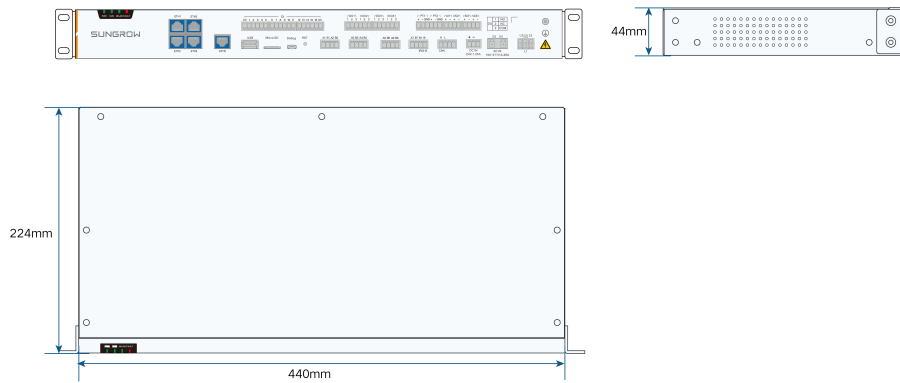

3 Unpacking and Storage

3.1 Scope of Delivery

The following items should be included.

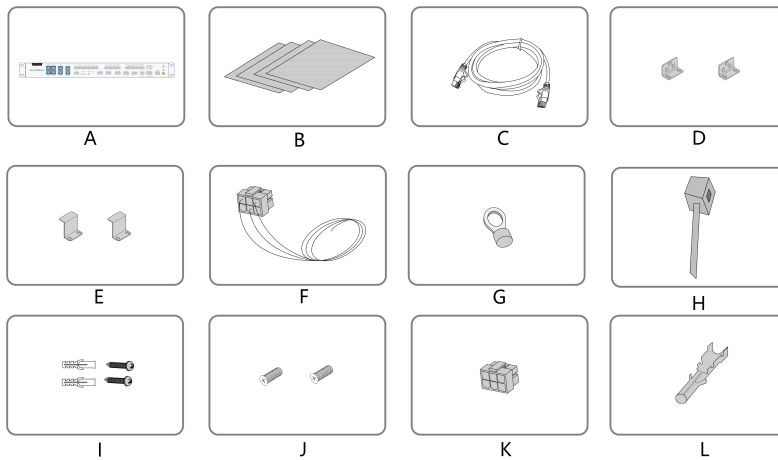

Item	Name	Description
A	Data Logger	-
B	Documents	Quick Installation Guide, quality certificate, packing list, product test report, and warranty card
C	Ethernet cable	1
D	Mounting ear	2
E	Bottom supporter	2
F	PLC cable	-
G	OT terminal	2
H	Nylon cable tie	10
I	Self-tapping screw assembly	8 sets, including ST4.8x19 expansion bolts and self-tapping screws, used for wall mounted installation

Item	Name	Description
J	Fastener assembly	6 sets, M4x8 cross recessed countersunk head screws, used to anchor the mounting ears to the Data Logger
K	Socket	1
L	Pin	6

3.2 Identifying the Data Logger

The model and important technical parameters of the Data Logger can be found on the nameplate. The nameplate is attached to the back of the data logger, as shown in Figure A.

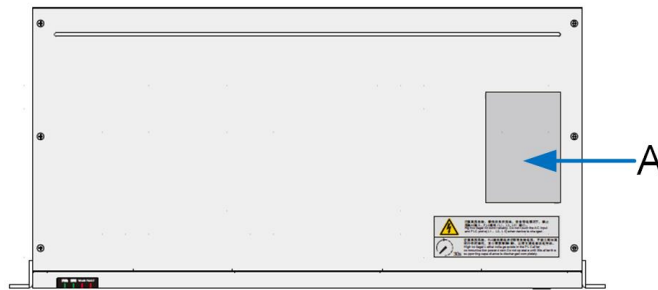

⚠ WARNING

The nameplate contains important parameters, which must be kept visible and free of stains and damage.

3.3 Checking upon Receiving

The product is thoroughly inspected and packed before delivery. However, it is possible for damage to occur during transport. Check the following items carefully once receiving the product:

- Check if the packing list matches the items included in the delivery. See [3.1 Scope of Delivery](#).
- Confirm that the received model is the same as the purchased one.
- Check the device thoroughly and ensure there are no visible damages.

If there are any problems, contact SUNGROW or the forwarding company.

⚠ WARNING

Proceed with installation and commissioning only if the product is intact without signs of damage! Before installation, ensure that:

- **The product is intact without any damages.**
- **Related documents, such as quick installation guide, are enclosed.**

3.4 Storage

If the Data Logger is not installed immediately after receiving, observe the following requirements to store it properly.

- Store the Data Logger in its original packing case in a well-ventilated, dry, and clean indoor environment.
- Ensure that the storage carrier can carry the weight of the Data Logger with the package.
- Ensure the device is kept in a well-ventilated and moisture-proof place, without accumulation of water.
- Ambient temperature: $-40^{\circ}\text{C}\sim+70^{\circ}\text{C}$. Relative humidity: 0~95%, no condensation.
- Take precautions to protect the device against damage due to harsh environment such as sudden temperature changes or collision.
- Conduct regular inspection, preferably at least once a week. Check whether the packaging is intact and prevent any damage that may be caused by pests and animals. Replace the packaging immediately if it is damaged.
- If the storage period exceeds six months, open the packaging to inspect the equipment and conduct power-on testing.

⚠ WARNING

- **Do not store the equipment without packaging!**
- **Do not store the equipment outdoors or under direct sunlight.**
- **No tilting or stacking!**



After long-time storage, thoroughly check the Data Logger and ensure it is undamaged before installation. If necessary, install the Data Logger only after it has been tested by qualified personnel.

4 Mechanical Installation

4.1 Installation Location Selection

Environment Requirements

- The Data Logger has an IP20 protection rating and should only be installed indoors.
- Ambient temperature: -30°C to $+60^{\circ}\text{C}$. Ambient relative humidity: 0% to 95% (no condensation). Excessive humidity may cause damage to internal components.
- Pay attention to moisture prevention and ensure that the installation environment is free from flammable, explosive, and chemically corrosive substances.

Clearance Requirements

- Before installing the Data Logger, ensure that there is sufficient space around the installation location.
- Ensure that the Data Logger is oriented correctly, with the wiring terminals positioned at the bottom. This helps prevent dust, particles, and other airborne substances from entering the equipment over time, which could potentially impact its service life.
- Keep the Data Logger at least 1,500mm above the ground surface. Reserve a clearance of at least 500mm for convenient maintenance and servicing. The following figure shows the required minimum spacing.

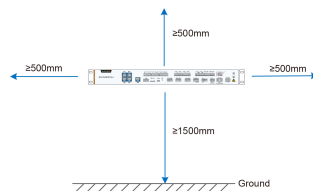

NOTICE

When connecting outdoor equipment, such as a Meteo Station, to the Data Logger, install a Surge Protection Device (SPD) to protect the communication system. Choose the right SPD based on the site conditions and requirements.

4.2 Installation Tools

Installation tools include, but are not limited to, the following recommended ones. If necessary, use other auxiliary tools on site.



Utility knife

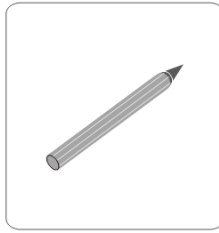

Marker

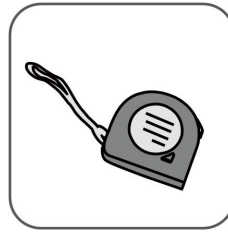

Measuring tape

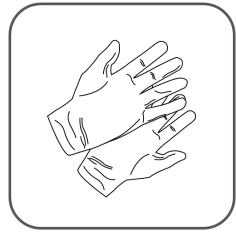

Protective gloves

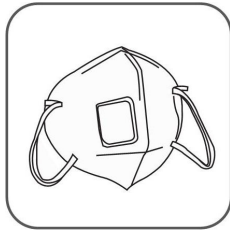

Dust mask



Safety footwear



Vacuum cleaner

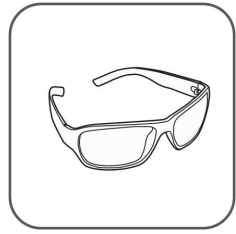

Goggles



Hammer drill



Electric
screwdriver

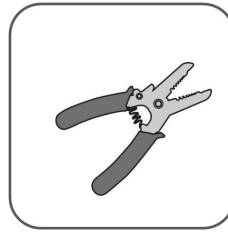

Wire stripper



Wire cutter

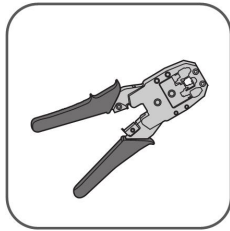

Wire crimping tool



Slotted
screwdriver



Phillips
screwdriver

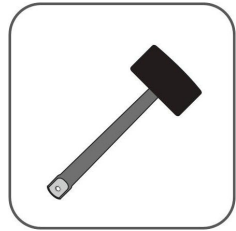

Rubber mallet

4.3 Mounting the Data Logger

As long as the installation environment requirements are met, the Data Logger can be installed at any suitable indoor location. The Data Logger can be rack-mounted or wall-mounted.

4.3.1 Wall-Mounted Installation

Prerequisite

⚠ DANGER

Avoid drilling holes in the utility pipes and/or cables attached to back of the wall!



When holes are punched on the mounting surface, it is recommended to turn on a vacuuming device and wear goggles and a dust mask to prevent dust from entering the eyes or being inhaled into the body.

Installed parts

- Marker, not included in the scope of supply
- Hammer drill, not included in the scope of supply
- Bottom supporter, included in the scope of delivery
- Mounting ear, included in the scope of delivery
- Expansion bolt, included in the scope of delivery
- Tapping screw, included in the scope of delivery
- Screwdriver, not included in the scope of delivery

Install Mounting Ears and Bottom Supporters

Anchor the mounting ears and bottom supporters to the Data Logger with supplied M4x8 cross recessed countersunk head screws. The fastening torque is 1.8-2.4N·m. The anchoring method is as follows:

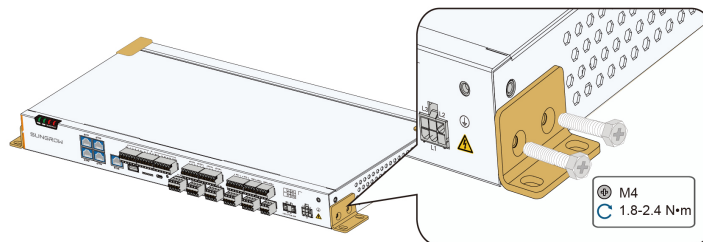

Mount the Data Logger to the Wall

- Step 1** Mark positions for drilling holes on the installation wall. Drill the holes with a hammer drill of $\phi 6\text{mm}$. (Note: Ensure the required spacing between the Data Logger and surrounding objects.)

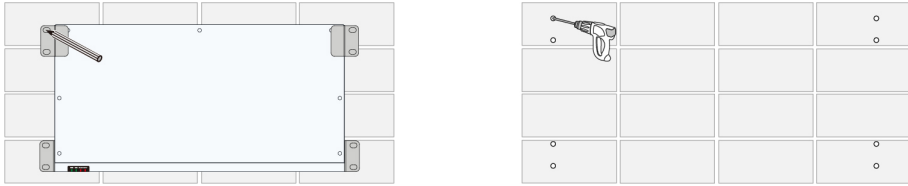

Step 2 Insert the expansion sleeve into the drilled hole, and make it completely embedded in the wall with a rubber hammer.

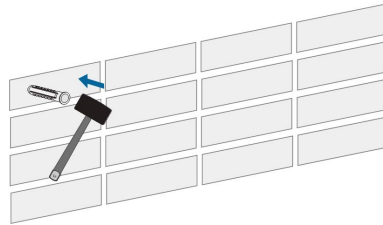

Step 3 Insert the tap screw and mounting ear successively into the expansion sleeve, to fix the Data Logger onto the wall.

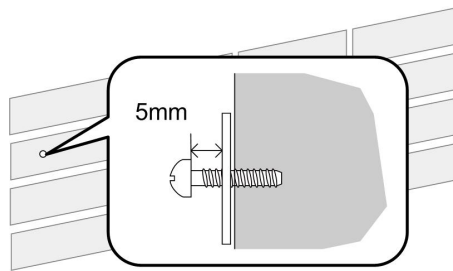

Step 4 Fasten the tapping screw with a screwdriver by the torque of 0.3N·m.

--End

4.3.2 Rack-Mounted Installation

Use 1U standard rack in case of the rack-mounted installation.

Prerequisite

The following lists the components, tools, and devices used during installation.

- 1U standard rack, not included in the scope of delivery
- Screwdriver, not included in the scope of delivery
- Screw, not included in the scope of delivery
- Nut, not included in the scope of delivery

Install mounting ears

Anchor the mounting ears to the Data Logger with supplied M4x8 cross recessed countersunk head screws. The fastening torque is 1.8-2.4N·m. The anchoring method is as follows:

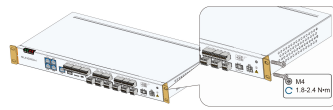

Step 1 Mark positions on the rack according to dimensions of the Data Logger.

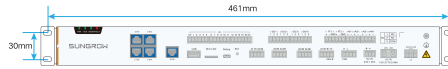

Step 2 Drill holes on the rack with a hammer drill of $\phi 6\text{mm}$.

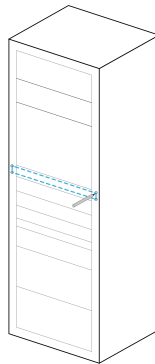

Step 3 Level the mounting ears with the drilled holes on the rack.

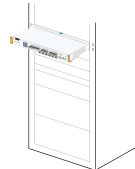

Step 4 Fix the Data Logger in the sequence of screws, mounting ears, rack, and nuts.

--End

5 Electrical Connection

5.1 Safety Instructions

⚠ DANGER

High voltage hazard!
 The Data Logger should be reliably ground. Never touch the AC power supply port "AC IN 100–277V, 0.48A" and MPLC communication port "L1/L2/L3" when the device is powered on.

NOTICE

High Risk hazard! Danger will be caused by touching the MPLC communication port immediately after powering down. Wait at least 30s to have the capacitor discharge completely.

NOTICE

Incorrect wiring may result in damage to the Data Logger and potential harm to the operator.

NOTICE

All cables are intact, well-insulated, and appropriately dimensioned.

5.2 Port Introduction

The layout and identifiers of the Data Logger terminals are shown below.

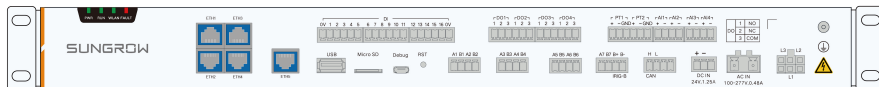

Symbol	Name	Recommended cables	Description
ETH1~ETH2	Ethernet port	-	Data exchange Ethernet port. Can be connected to the SCADA using devices.
ETH3~ETH4	Fast dispatch port	-	Used for active and reactive fast scheduling using Goose.

Symbol	Name	Recommended cables	Description
ETH5	Ethernet port	-	Reserved for master/standby functions.
DI	Digital input	0.75mm ² outdoor anti-ultraviolet wire	Passive dry contact input port
USB	USB port	-	Reserved
Micro SD	SD port	-	Used for software programming (this port is only available to SUNGROW technicians)
Debug	Debug port	-	Used for debugging of the Data Logger
RST	Reset	-	Press and hold it for > 30s to restore the default settings. Press and hold it for < 3 seconds, reserved
DO1~DO4	Digital output	0.75mm ² outdoor anti-ultraviolet wire	Relay output interface Relay specification: 250Vac/1A or 30Vdc/1A
PT1 and PT2 AI1~AI4	Analog input	0.75mm ² outdoor anti-ultraviolet wire	PT100/PT1000 detect range: -30°C ~120°C Two-wire or three-wire connection method AI1: 0~10Vdc AI2-AI4: 4~20mA
A1B1~A7B7	RS485 communication interface	2 x (0.75~1.5) mm ² outdoor anti-ultraviolet twisted pair with a shielding layer	Support of 7 inputs of RS485 Can be connected to both slave device and SCADA
IRIG-B	Inter-Range Instrumentation Group-Time Code Format B	-	Reserved

Symbol	Name	Recommended cables	Description
CAN	CAN communication port	-	Reserved
DC IN 24V, 1.25A	DC24V power supply port	0.75~1.5mm ² outdoor anti-ultraviolet wire	If the current is ≤1.25A, the switch mode power supply at this port requires reinforced insulation.
AC IN 100~277V, 0.48A	AC power supply port	0.75~1.5mm ² outdoor anti-ultraviolet wire	Connecting 100~277Vac (50/60Hz), current≤0.48A
	Grounding hole	1~1.5mm ² outdoor anti-ultraviolet wire	Connecting protective grounding cable
L1, L2, L3	MPLC communication interface	0.5~0.75mm ² , cable withstand voltage: cable grounding working voltage ≥ 1000 V	Can be connected to string inverters equipped with PLC communication function



- In this manual, “AI” stands for “Analog Input.” The abbreviation will be used in the following descriptions.
- In this manual, “DI” stands for “Digital Input” The abbreviation will be used in the following descriptions.
- In this manual, “DO” stands for “Digital Output” The abbreviation will be used in the following descriptions

AC power supply port and MPLC communication interface

High voltages may be present on the AC power supply port “AC IN 100~277V, 0.48A” and MPLC communication port “L1, L2, L3”. Therefore, before cable connection, ensure that the ports are free of voltage and the grounding cable is reliably connected.

Digital input/output ports

Digital input/output ports (DI and DO1~DO4) are configured to collect node data and control node communication.

RS485 communication ports

For the RS485 communication ports (A1B1~A7B7), the communication distance should be no more than 1,000m.

5.3 Wiring Overview

The Data Logger:

- can be connected to devices in the PV system such as the inverter, combiner box, Meteo Station, and energy meter through the RS485 port.
- can be connected to SCADA devices through the Ethernet port.
- can be connected to transformer or other devices through the MPLC port.

5.4 Connecting to the Inverter

5.4.1 Connecting to the Device with RS485 Port

Use an RS485 shielded twisted pair (STP) to connect any RS485 port (A1B1~A7B7) of the Data Logger and the RS485 communication terminal of the inverter.

Connecting to a Single Inverter



Connecting to Multiple Inverters

Multiple inverters are connected to the Data Logger in the RS485 daisy chain manner.

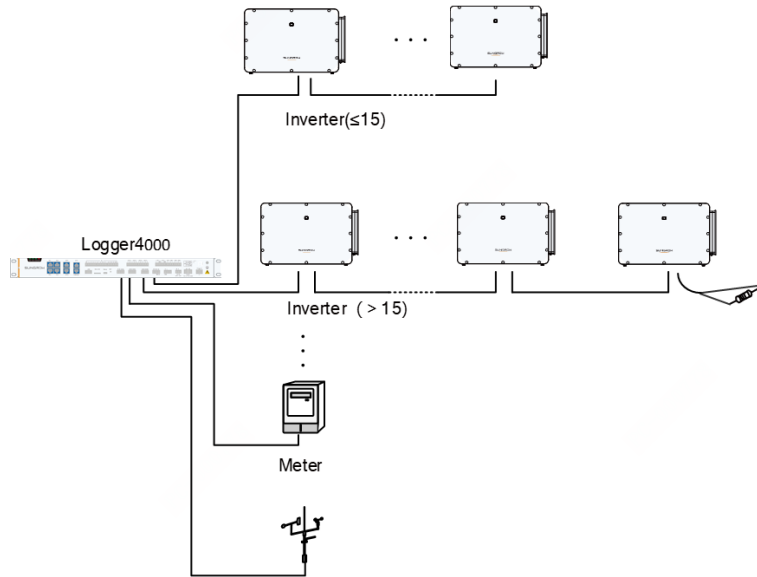

- The Data Logger supports 7 RS485 buses and 300 devices at most. Each RS485 bus supports 80 devices at most.
- Devices of different types must be connected to different RS485 communication ports of the Data Logger. For example, the transformer and the inverter should be connected to different RS485 communication ports of the Data Logger.
- The address of each device on the RS485 bus should be within the set address range (1 to 246) of the Data Logger, and duplicate addresses are not allowed. Otherwise, communication failure occurs.
- Serial port parameters of each device on the RS485 bus should be consistent with those of the Data Logger. The serial port parameters include baud rate, data bit, stop bit, and check bit.
- To ensure stable system communication and accurate data acquisition, make sure that all inverters connected to the same transformer winding access the data logger via the same RS485 channel. Inverters under different windings must not be daisy-chained to the data logger via RS485; otherwise, data acquisition may fail. Any issues arising from such improper connections are not covered by the warranty.

Connection Method

- Step 1** Lead the RS485 communication cable from the inverter to the wiring area of the Data Logger.
- Step 2** Strip the protection layer of the communication cable with a wire stripper. Cable specification and stripped length are as follows.

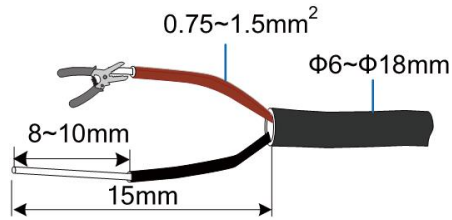

Step 3 Install appropriate cord end terminals on the communication cables after removing the protective layer, and use a crimping tool to securely crimp them.

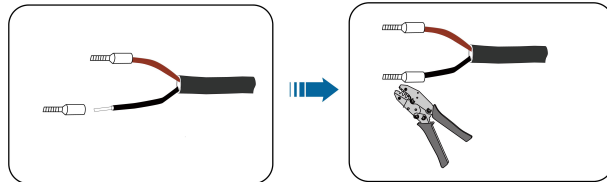

Step 4 Crimp the wiring terminals.

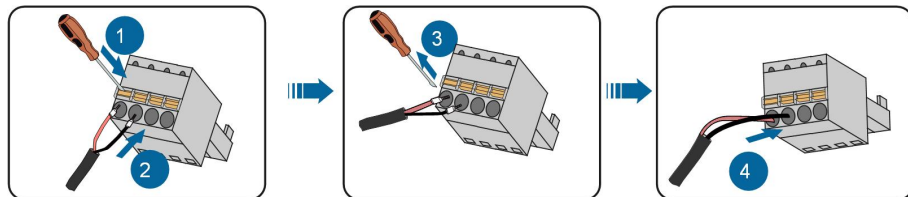

NOTICE

- Connect RS485A to port A and RS485B to port B.
- The RS485 communication cable must be the shielded twisted pair with the shielding layer single-point grounded.



When a multi-core and multi-strand copper core cable is used, the communications cable connected to an RS485 port on Logger must be crimped to cord end terminals of proper specification.

Step 5 Connect the wiring terminal to the terminal "A1B1~A7B7" of the Data Logger.

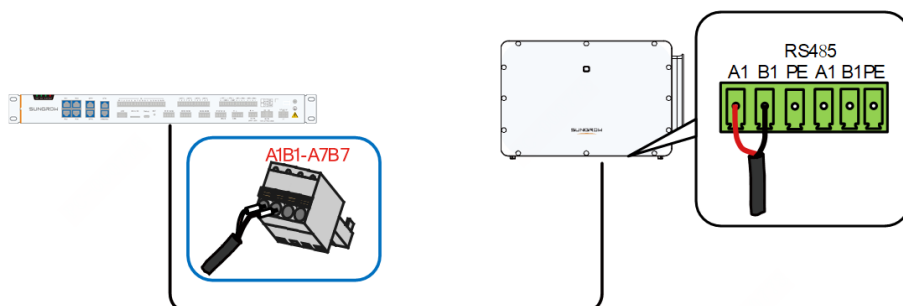

--End

5.4.2 Connecting to the Inverter with MPLC Port

Integrated with MPLC master node, the Data Logger can be connected to the inverter integrated with MPLC slave node and achieve MPLC communication by using existing power cable.

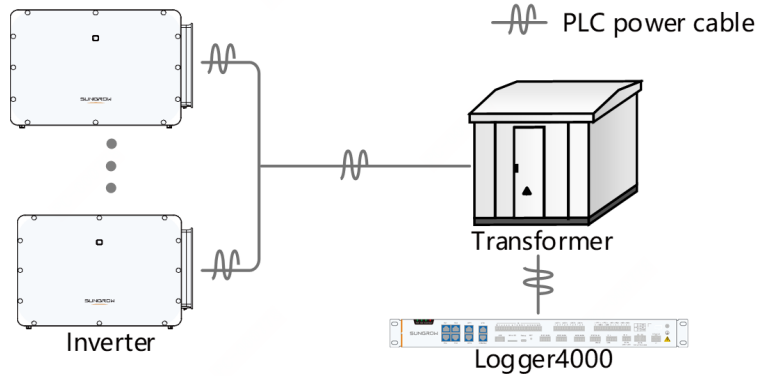

Preparation

- Disconnect the transformer from the grid.
- Disconnect the DC side of the inverter and make sure the system is in safe state.
- If the MPLC cable in the scope of delivery is found short on site, prepare the MPLC cable referring to the following steps.
 1. Strip the protection layer of the MPLC cable with a wire stripper. Stripped length are as follows.

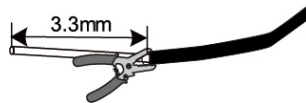

2. Install the pin on the MPLC cable after the protective layer has been removed, and crimp the MPLC cable using crimping tools. Prepare three MPLC cables with pins.

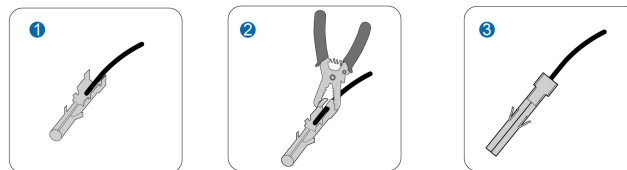

3. Connect the pins of the cables to the socket, as shown in the following figure.

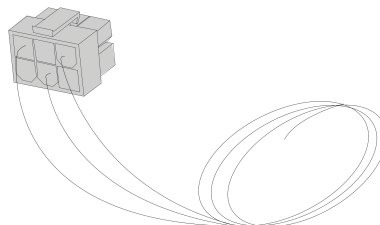

Connection Method

Connect one end of the MPLC power cable in the scope of delivery to MPLC ports L1, L2, and L3 of the Data Logger, and the other end to the three-phase ports of the circuit breaker.

The L1 port of the Data Logger must be connected to phase A of the circuit breaker, the L2 port to phase B, and the L3 port to phase C. The details are as follows.

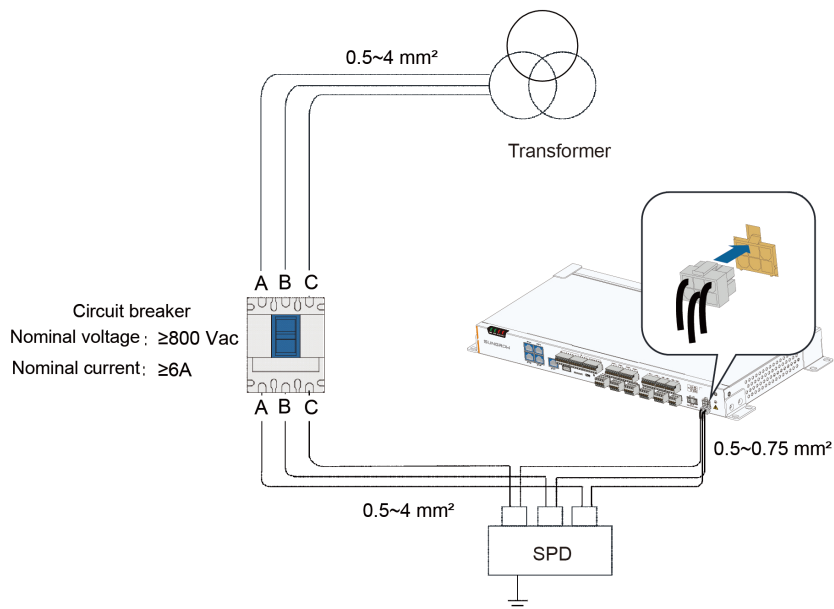

The external circuit breaker is not included in the scope of delivery, and users need to prepare it by themselves if necessary.

The external circuit breaker just needs to meet the above two parameters (nominal voltage and nominal current). Other parameters, such as breaking capacity, are not mandatory requirement.

NOTICE

Isolation voltage of the MPLC cable should be greater than 1,000V, recommended cable specification: 0.5~0.75mm².

The MPLC connection cable must be connected to a three-level surge protector, otherwise it may cause damage to the equipment.

NOTICE

The built-in MPLC module of the Data Logger supports AC voltage less than 1000V. When using the MPLC communication method, the communication distance between the Data Logger and the inverter should not exceed 1000 meters.

NOTICE

MPLC networking is intended for medium voltage grid-connection. If low voltage grid-connection is desired, observe the following two conditions:

- **Never connect a load between the Data Logger and the MPLC slave node.**
- **The distance between the Data Logger and the load should be greater than 20m, that is, the LV grid-connection point should be more than 20m away from the nearest load distribution line. The load includes air conditioners, machines, motors, etc.**

NOTICE

When using the MPLC communication method, consider the following:

- **The electrical connection between the inverter and the downstream transformer has been successfully established and verified to be correct.**
- **Input and output circuit breakers of the Data Logger, inverter, and transformer are connected.**

5.5 Connecting to the Meteo Station

Meteo Station of the Modbus-RTU protocol can be connected to the Data Logger.

- Step 1** Lead the RS485 communication cable from the Meteo Station to the wiring area of the Data Logger.
- Step 2** Strip off the protective layer and insulation layer of the communication cable with wire strippers, as shown below.

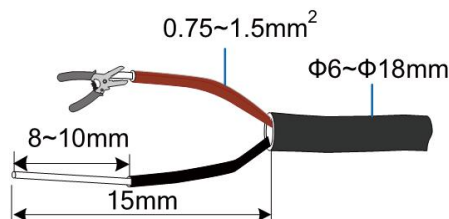

- Step 3** Install appropriate cord end terminals on the communication cables after removing the protective layer and insulation layers, and use a crimping tool to securely crimp them.

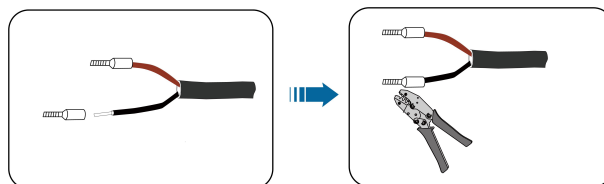

- Step 4** Connect the cable to the RS485 port of the Data Logger, as shown in the figure below.

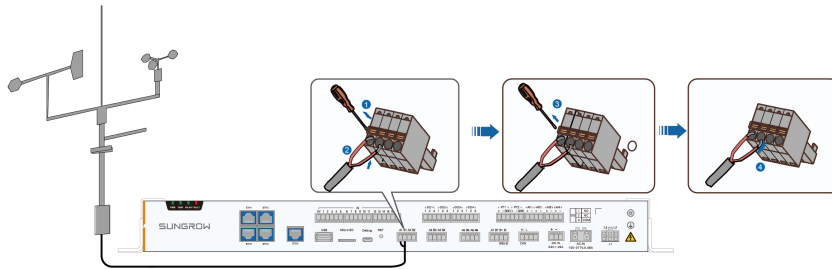

--End

5.6 Connecting to the Energy Meter

The Logger can be connected to the energy meter through the RS485 port or the Ethernet port. Specifically, refer to the table below.

Brand	Communication Port	Port definition	Protocol Type	Wiring
Wasion	24	RS485-A	Modbus RTU	
	25	RS485-B	Modbus RTU	
	26	Public	Modbus RTU	
	27	RS485-A	Modbus RTU	
	28	RS485-B	Modbus RTU	
Acrel	21	RS485-A	Modbus RTU	5.6.1 RS485 Cable Connection
	22	RS485-B	Modbus RTU	
Weidmüller EM610	17	RS485-A	Modbus RTU	
	16	RS485-B		
Janitza UMG604	22	RS485-B	Modbus RTU	
	23	RS485-A		
	Ethernet	Ethernet	Modbus TCP	

5.6.1 RS485 Cable Connection

Step 1 Lead the RS485 communication cable from the meter to the wiring area of the Data Logger.

Step 2 Strip off the protective layer and insulation layer of the communication cable with wire strippers, as shown below.

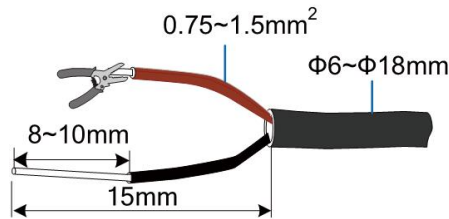

Step 3 Install appropriate cord end terminals on the communication cables after removing the protective layer and insulation layers, and use a crimping tool to securely crimp them.

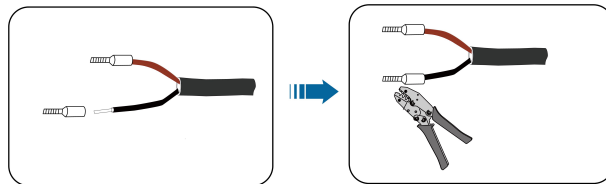

Step 4 Connect the cable to the RS485 port of the Data Logger, as shown in the figure below.

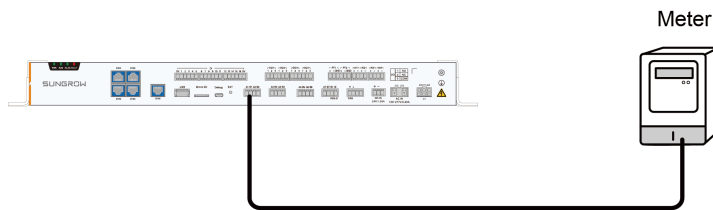

--End

5.6.2 Ethernet Cable Connection

Connect the "Ethernet" port of the energy meter and the "ETH1, ETH2, ETH5" port of the Data Logger with a network cable.

5.7 Wiring of DI Signal

The DI port is used to access DI signals, such as grid dispatching instructions and alarms. Only passive dry contact signals are supported. It is recommended that the signal transmission distance not exceed 10m.

Step 1 Strip the protection layer and insulation layer of the dry contact input signal cable with a wire striper, as shown in the figure below.

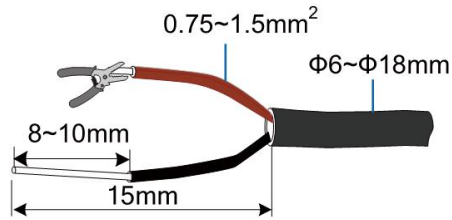

Step 2 Install cord-end terminals and crimp them with crimping pliers.

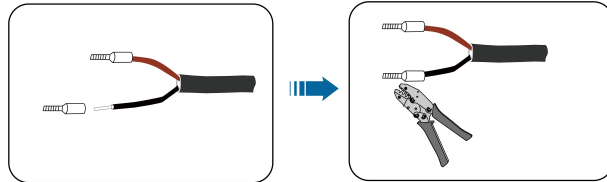

Step 3 Connect the cord end terminals to the plug "DI" outside the Data Logger, as shown below. Port "OV" and Port "1" are taken as an example.

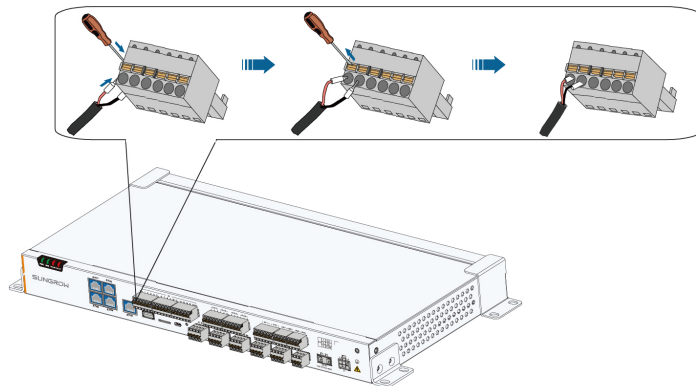

--End

5.8 Wiring of DO Signal

Port 1 corresponds to NO, port 2 to NC, and port 3 to COM. NO/COM is the normally open contact, and NC/COM is the normally closed contact. It is recommended that the signal transmission distance not exceed 10m.

Step 1 Strip the protection layer and insulation layer of the dry contact output signal cable with a wire stripper, as shown in the figure below.

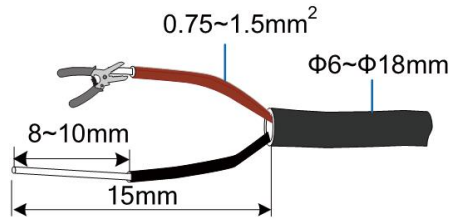

Step 2 Install cord-end terminals and crimp them with crimping pliers.

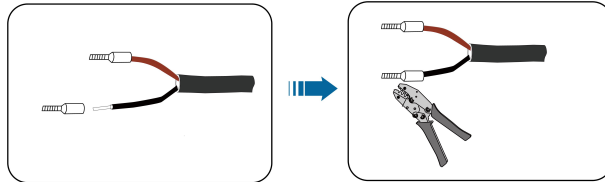

Step 3 Connect the cord end terminals to plugs "DO1"~"DO4" outside the Data Logger, as shown below. Port "DO1" is taken as an example.

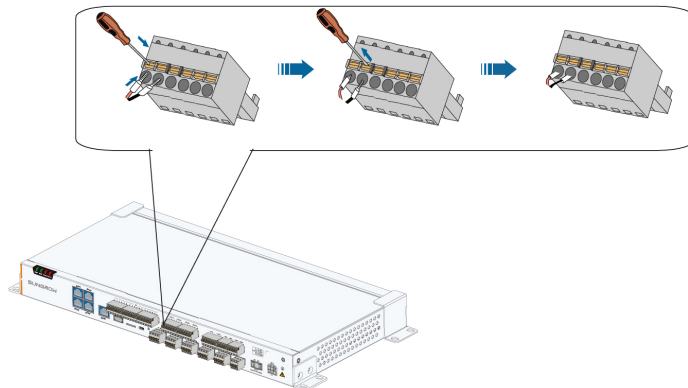

--End

5.9 Wiring of AI Signal

The AI port is used to access AI signals of devices such as environmental monitoring sensors. It is recommended that the signal transmission distance not exceed 10m.

Step 1 Strip the protection layer and insulation layer of the analog input signal cable with a wire stripper, as shown in the figure below.

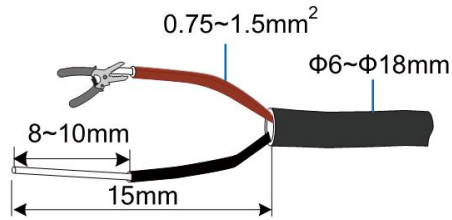

Step 2 Install cord-end terminals and crimp them with crimping pliers.

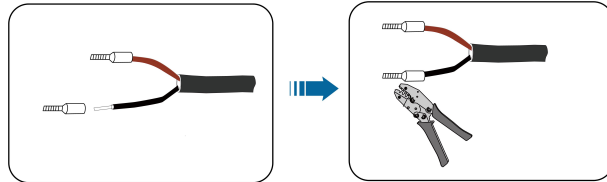

Step 3 Connect the cord end terminals to plugs "AI1"~"AI4" outside the Data Logger, as shown below. Port "AI1" is taken as an example.

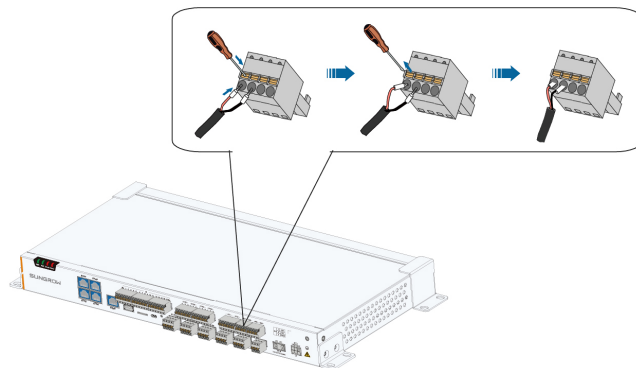

--End

Port	Symbol	Description
AI	AI1	Supported voltage input range: 0V~10Vdc
	AI2	Supported current input range: 4mA~20mA
	AI3	
	AI4	



AI + is connected to AI signal +, AI - is connected AI signal -.

5.10 Wiring of PT Signal

The Data Logger is designed with two PT ports and supports 3-wire or 2-wire PT100/PT1000 temperature sensor connection.

Step 1 Strip the protection layer and insulation layer of the signal cable for temperature detection with a wire stripper, as shown in the figure below.

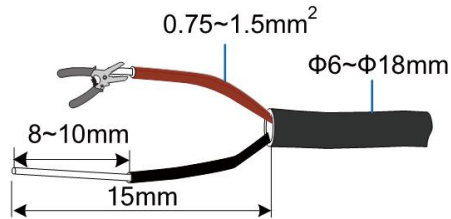

Step 2 Install cord-end terminals and crimp them with crimping pliers.

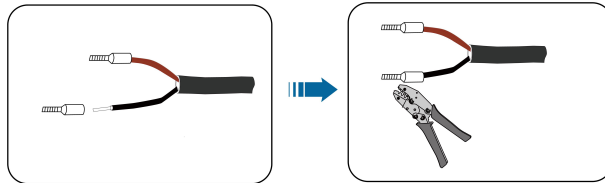

Step 3 Connect the cord end terminals to plugs "PT1"~"PT4" outside the Data Logger, as shown below. Port "PT1" is taken as an example.

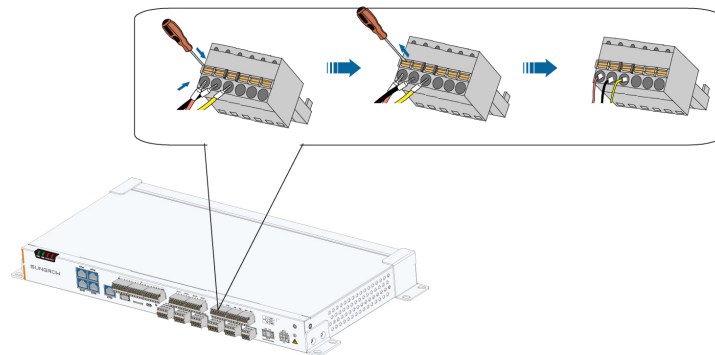

Figure 5-1 3-wire PT100/PT1000 connection

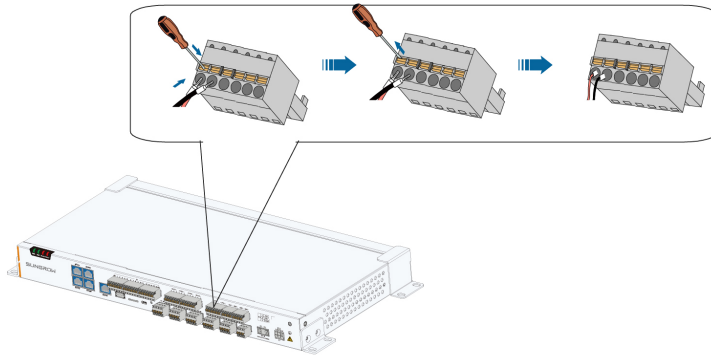

Figure 5-2 2-wire PT100/PT1000 connection

--End

5.11 Connecting to the Remote Monitoring Device

The Data Logger can be connected to the SCADA with an Ethernet switch or a router.

The Data Logger is equipped with three Ethernet ports: ETH1, ETH2 and ETH5. Access the Ethernet switch and the router through either port. This section takes connecting to an Ethernet switch as an example to illustrate the wiring steps.



The ETH5 network port is only for debugging and cannot be connected to the SCADA communication system.

Step 1 Insert one plug of the supplied network cable into the network port of the Ethernet switch and the other plug into the ETH port of the Data Logger.

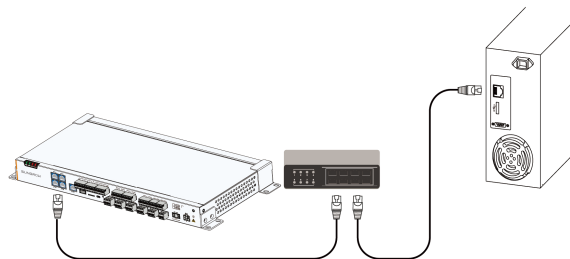

Step 2 Set network parameters.

--End



- For the default IP address of Ethernet ports (ETH1, ETH2, ETH5), see [6.2 Commissioning Step](#).
- If the DHCP (Dynamic Host Configuration Protocol) feature is enabled for the Ethernet port (ETH1, ETH2, and ETH5), its IP address can be retrieved after it is connected to a router or other device.

5.12 Connecting to the AC Power Supply

The Data Logger can be connected to a power source with voltage ranging from 100 to 277Vac.

Step 1 Lead the external power supply cable to the wiring area of the Data Logger.

Step 2 Strip off the protective layer and insulation layer of the power cable with wire strippers, as shown below.

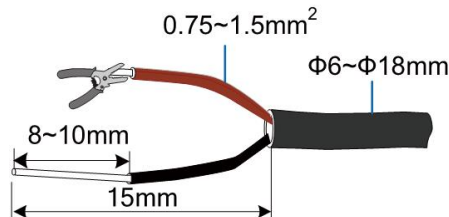

Step 3 Install appropriate cord end terminals on the power cables after removing the protective layer and insulation layers, and use a crimping tool to securely crimp them.

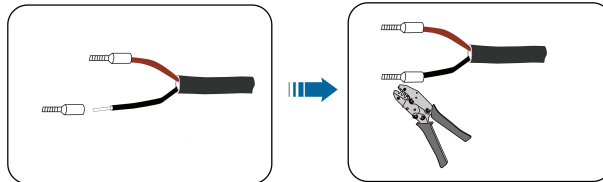

Step 4 Connect the cord end terminals to the plug "AC IN 100~277V, 0.48A" outside the Data Logger.

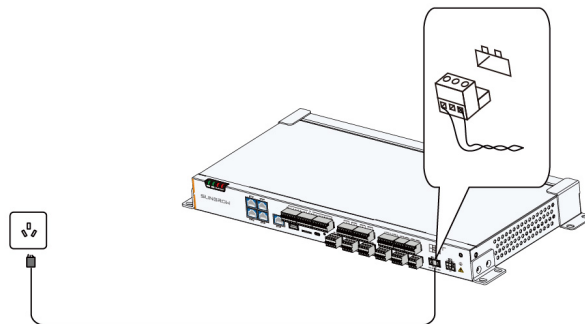

--End



The Data Logger can be connected to both AC power supply and DC power supply. UPS can be used as a DC backup power source.

5.13 Connecting to the DC Power Supply

The Data Logger can be connected to 24Vdc external power supply. UPS can be used as a power source.

Step 1 Lead the external power supply cable to the wiring area of the Data Logger.

Step 2 Strip off the protective layer and insulation layer of the power cable with wire strippers, as shown below.

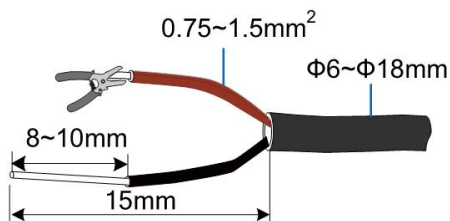

Step 3 Install appropriate cord end terminals on the power cables after removing the protective layer and insulation layers, and use a crimping tool to securely crimp them.

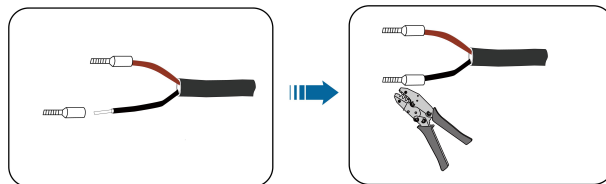

Step 4 Connect the cord end terminals to the plug "DC IN 24V, 1.25A" outside the Data Logger.

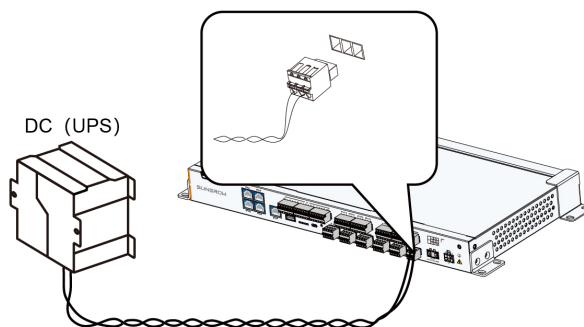

--End

5.14 Earthing Connection

Prerequisite

⚠ WARNING
The grounding cable should be grounded reliably. Otherwise: It may cause fatal electric shock to the operator in case of failure. The equipment may be damaged when struck by lightning.

Step 1 Strip the protection layer and insulation layer of the grounding cable by specific length, as shown in the figure below.

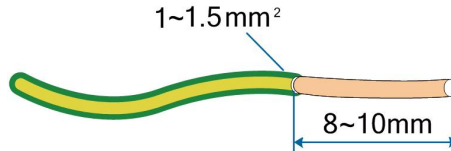

Step 2 Select proper OT terminal and crimp them.

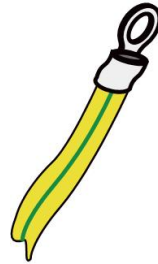

Step 3 Secure the grounding cable to the grounding hole of the Data Logger, as shown in the figure below.

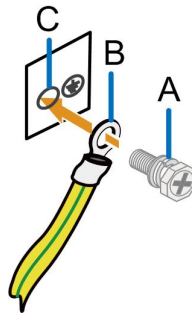

Item	Definition	Remarks
A	Screw	M4
B	OT terminal	-
C	Grounding hole	-

Step 4 Fasten the screw with a wrench by the torque of $5 \pm 1 \text{N} \cdot \text{m}$.

--End

6 Commissioning

6.1 Inspection before Commissioning

No.	Check Item	Result
1	All cables are intact, well-insulated, and appropriately dimensioned.	<input type="checkbox"/>
2	All cables are connected correctly and firmly.	<input type="checkbox"/>
3	The polarity of the power supply cable is correct. The grounding cable is reliably grounded.	<input type="checkbox"/>

6.2 Commissioning Step

Item	Description
1	Connect the commissioning PC to one of ETH1, ETH2, ETH5 ports of the logger with a network cable. <ul style="list-style-type: none">• ETH1, default IP: 12.12.12.12, virtual IP: 15.15.15.15• ETH2, default IP: 13.13.13.13, virtual IP: 16.16.16.16• ETH5, default IP: 14.14.14.14, virtual IP: 17.17.17.17
2	Power on the Data Logger.
3	Observe whether the indicator RUN at the exterior of the Data Logger flickers normally.
4	Access the default IP address of the connected port using Internet Explorer, Safari, or Chrome.
5	Configure serial port parameters on the Web interface.
6	Add PV devices connected to the Data Logger to the Web interface by searching for them or manually adding them.
7	Configure IP address.
8	Configure iSolarCloud address if inverter data needs to be uploaded to iSolarCloud. The default iSolarCloud server is " Chinese Server ".

Item	Description
	<p>Users in mainland China select “Chinese Server”.</p> <p>Users in Europe select “European Server”.</p> <p>Users in Australia select “Australian Server”.</p> <p>Users in other regions select “International Server”.</p>
9	Navigate to the web interface of the Data Logger to verify the operation of the string inverters manufactured by SUNGROW by reviewing their operational data.
10	<p>Create a plant via the iSolarCloud App and verify the accuracy of the data.</p> <p> iSolarCloud is not applicable to in North America.</p>

Item	Description
1	<p>Connect the commissioning PC to one of ETH1, ETH2, ETH5 ports of the logger with a network cable.</p> <ul style="list-style-type: none"> • ETH1, default IP: 12.12.12.12, virtual IP: 15.15.15.15 • ETH2, default IP: 13.13.13.13, virtual IP: 16.16.16.16 • ETH5, default IP: 14.14.14.14, virtual IP: 17.17.17.17
2	Power on the Data Logger.
3	Observe whether the indicator RUN at the exterior of the Data Logger flickers normally.
4	Access the default IP address of the connected port using Internet Explorer, Safari, or Chrome.
5	Configure serial port parameters on the Web interface.
6	Add PV devices connected to the Data Logger to the Web interface by searching for them or manually adding them.
7	Configure IP address.
8	Navigate to the web interface of the Data Logger to verify the operation of the string inverters manufactured by SUNGROW by reviewing their operational data.

Use the iSolarCloud App to create a new plant. Scan the QR code on the front label of the Data Logger, or manually enter the serial number (S/N) to add the communication equipment. For details, refer to the Quick Guidance of iSolarCloud App. Scan the QR Code to view or obtain the Quick Guidance of iSolarCloud App.



7 Web Main Interface

7.1 Log In to the Web UI

Information Required for Login

Table 7-1 Initial Usernames and Passwords

User Type	Username	Default Password	Permissions
General User	user	Username + S/N	Monitoring permissions and basic setting permissions only, such as viewing Overview, device monitoring, and some historical data.
O&M User	maintain	Username + S/N	All operations described in this manual by default.
Audit User	auditor	Username + S/N	Audit the operation logs, parameter logs, and syslog logs of all users.
Administrator	administrator	Username + S/N	Add, delete, modify, and clear users; manage sessions; enable or disable developer debugging; assign certificates.
Developer User	develop	Generate a dynamic password based on the S/N obtained through customer authorization.	After authorization by the administrator, diagnose and clear complex device faults.



Starting from Logger4000 firmware version P018, the Web UI provides the user management function. For details, see [10 User Management](#).

Table 7-2 ETH Port Information

Port	IP Address	Subnet Mask
ETH1	Default IP address: 12.12.12.12 Virtual IP address: 15.15.15.15	
ETH2	Default IP address: 13.13.13.13 Virtual IP address: 16.16.16.16	255.255.255.0
ETH5	Default IP address: 14.14.14.14 Virtual IP address: 17.17.17.17	

Prerequisite

- Connect the data logger and the PC through an Ethernet cable.
Using a connection through the ETH1 port as an example:

Step 1 Modify the PC network settings to ensure that the PC IP address is in the same network segment as the data logger.

Setting Item	Data Logger Default Setting	PC Setting Example
IP address	12.12.12.12	12.12.12.125
Subnet mask	255.255.255.0	255.255.255.0



When configuring the IP address, ensure that the first three numbers are the same. The fourth number ranges from 0 to 255 (excluding 12).

Step 2 In the browser address bar, enter `http://12.12.12.12` or `https://12.12.12.12` and press **[Enter]** to access the Web UI.



- To log in to the Logger4000 Web UI, enter 12.12.12.12, `http://12.12.12.12`, or `https://12.12.12.12` directly in the PC address bar. All three methods are supported.
- Using HTTPS is recommended for secure access.

Step 3 Log in to the Web UI as an O&M user.

- In the upper right corner of the Web UI, click  to open the login dialog box.
- Enter the username and password based on the dialog box displayed.

After login, the Web UI displays the O&M user interface.

Step 4 Check the Logger4000 firmware version and confirm whether an upgrade is required. See [7.8.16 Viewing the Firmware Version](#).



If an upgrade is required, see [8.2 Updating the Data Logger](#).

--End

7.2 Modifying Password

NOTICE

To keep your account secure, it is recommended to change the password regularly and always make sure you remember the new one. Not changing the default password can lead to unauthorized access, and continued use of the initial password increases the risk of theft and hacking. Additionally, loss of the password can prevent access to the device, potentially causing losses to the power station. In these cases, SUNGROW shall not be liable for any losses incurred due to non-compliance with the recommended security practices.

Step 1 Click  > **Modify Password** to enter the corresponding page.

Step 2 In the pop-up **Modify Password** dialog box, enter the **Old Password** and **New Password**, and then **Confirm New Password**.



Please change the initial password upon first login.
Passwords should be 8–32 character long and contain at least three of the following four character types: uppercase letters, lowercase letters, numbers, and special characters. The new password cannot be the same as the old one.

Step 3 Click **Save** and log into the system using the new password.

--End



If you forgot your password, contact system administrator or SUNGROW.

7.3 Web UI Overview

7.3.1 Web Main Interface

When logging into the web for the first time as an O&M user, the **Help** page pops up. Follow the instruction to perform operations such as time synchronization, device connection, and forwarding configuration.

The main interface is as follows:

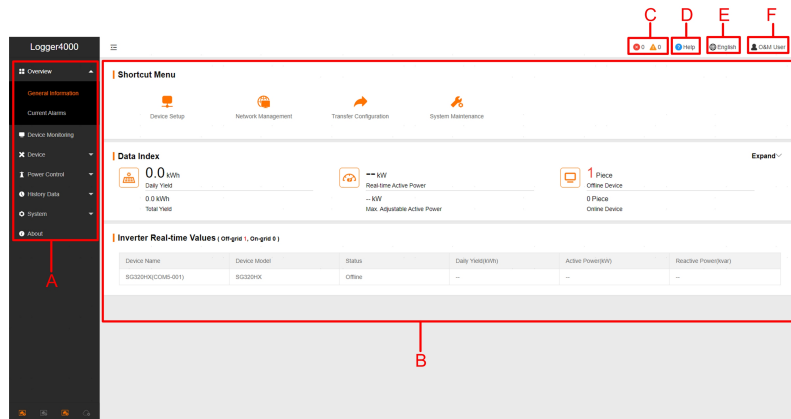

Item	Name	Description
A	Navigation menu	Display main function modules of the Web
B	Function display area	Display the current interface
C	Alarm icon	Display the current alarm level and alarm number. Users can click the icons to enter the corresponding alarm page.
D	Help	Display the basic configuration steps of the Data Logger.
E	Language menu	Click the button to select the desired language.
F	User	Display the current login user.

 indicates the connection status of the Data Logger's Ethernet port.

 indicates the connection status of the Data Logger's cloud service.

7.3.2 Running Requirements

Item	Description
Browser	Chrome65 or later, and Safari11 or later
Min. resolution	1024*768

Item	Description
Language menu	<p>The Web UI supports eight languages currently: Simplified Chinese, English, German, Spanish, Brazilian Portuguese, French, Japanese, and Korean.</p> <div style="border: 1px solid gray; padding: 5px; margin-top: 10px;">  <p>When logging in to the built-in Web, ensure your computer's system language matches one of the supported languages listed above; otherwise, access to the Web will not be possible.</p> </div>

7.3.3 Operation Procedure

Prerequisite

- Finished the electrical connection.
- Logged into the Web.

Step 1 Configure serial ports of the Data Logger.

After logging into the Web, first configure the serial ports to ensure that the Data Logger can normally communicate with downstream devices. See [7.8.13 Port Parameter](#).

Step 2 Calibrate the system time.

Check whether the current system time is correct, and perform manual time synchronization or automatic time synchronization when necessary. See [7.8.5 System Time](#).

Step 3 Add the device via auto search.

Devices that can be automatically searched, such as SUNGROW string inverter, can be added via the auto search function with addresses allocated automatically. See [7.6.1 Device List](#).

Step 4 Add other devices. See [7.6.1 Device List](#).

Step 5 Configure forwarding service.

After all devices have been added, configure the forwarding service to ensure that the Data Logger can forward the data to upstream devices. See .

--End

7.4 Overview

7.4.1 General Information

Click **Overview > General Information** to enter the corresponding page.

The screenshot displays the Web Main Interface with the following sections:

- Shortcut Menu:** Contains four icons for Device Setup, Network Management, Transfer Configuration, and System Maintenance.
- Data Index:** Shows key performance indicators:
 - Daily Yield: 0.000 kWh
 - Total Yield: 0.000 kWh
 - Real-time Active Power: 0.000 kW
 - Max. Adjustable Active Power: 0.000 kW
 - Offline Device: 5 Piece
 - Online Device: 1 Piece
- Inverter Real-time Values (off-grid 2, On-grid 0):** A table with the following data:

Device Name	Device Model	Status	Daily Yield(kWh)	Active Power(kW)	Reactive Power(kvar)
SG75TX(COM1-1)	SG75TX	Offline	555.5	--	--

Shortcut Menu

- **Device Setup:** Click the menu to add, delete, modify, and view the device or perform auto search operation to search the device to which address will be automatically allocated. See [7.6.1 Device List](#).
- **Network Management:** Set Ethernet parameters. See [7.8.13 Port Parameter](#).
- **Transfer Configuration:** Transfer the data connected by the system to the SCADA. See .
- **System Maintenance:** Support of operations such as system upgrade, log export, and rebooting. See [7.8.2 System Maintenance](#).

Data Index

Information such as today yield, total yield, real-time active power, number of offline devices, and real-time reactive power, reactive power range, active power set, and reactive power set can be viewed.

Click **Expand** to view more information.

Inverter Realtime Values

Information on the inverter such as state, daily yield, active power, and reactive can be viewed.

7.4.2 Current Alarms

Click **Overview > Current Alarms** to enter the corresponding page.

Information such as device name, alarm name, alarm type, alarm time, fault code, and fault ID can be viewed.

7.5 Device Monitoring

Click **Device Monitoring** to view the corresponding information.

Device information such as real-time values, DC data, initial parameter, protection parameter, general parameter, device instruction and device information can be viewed on this interface.

7.5.1 RealTime Values

Realtime information such as power generation, device state, and active power can be viewed on this page.

Step 1 Click **Device Monitoring > Realtime Values** to view the corresponding information.

Step 2 Click  to select the device type.

--End

7.5.2 DC Info

On this interface, voltage and current information of multiple inputs of MPPTs and strings can be viewed.

- Click **Device Monitoring > DC Info** to view the corresponding information.

7.5.3 Initial Parameter

Select the inverter and configure the initial parameter settings. Both individual and batch settings are supported.

Step 1 Click **Device Monitoring > Initial Parameter** to enter the corresponding page.

Step 2 Click  in the device list on the left, select the device type in the drop-down list, and then select the device.

Step 3 Select **Country/Region** and **Grid Type**.

Step 4 Click **Settings** to set initial parameters for an individual device.

Step 5 Set the initial parameters in batch.

- a. Click **Configure Synchronization**.
- b. Select the desired devices in the pop-up dialog, and click **Save** to apply the changes.

--End

7.5.4 Operation Parameters

- Click **Device Monitoring > Operation Parameters** to enter the corresponding page and set the operation parameters.

Both individual and batch settings are supported. For configuration methods, see [7.5.3 Initial Parameter](#).

7.5.5 System Parameters

- Click **Device Monitoring > System Parameters** to enter the corresponding page and set the system time of the device.

Both individual and batch settings are supported. For configuration methods, see [7.5.3 Initial Parameter](#).

7.5.6 Protection Parameter

- Click **Device Monitoring > Protection Parameters** to enter the corresponding page and set the protection parameters.

Both individual and batch settings are supported. For configuration methods, see [7.5.3 Initial Parameter](#).

7.5.7 Protection Parameters (Other)

- Click **Device Monitoring > Protection Parameters (Other)** to enter the corresponding page and set the protection parameters.

Both individual and batch settings are supported. For configuration methods, see [7.5.3 Initial Parameter](#).



Protection Parameters (Other) may vary by inverter model. Please refer to the actual page.

7.5.8 Power Regulation Parameters

- Click **Device Monitoring > Power Regulation Parameters** to enter the corresponding page and set the power regulation parameters.

Both individual and batch settings are supported. For configuration methods, see [7.5.3 Initial Parameter](#).

7.5.9 Fault Recording Parameters



For LOGGERSV400.001.00.P031 and later versions, only inverters with the fault recording function support the configuration of fault recording parameters.

Step 1 Choose **Device monitoring > Fault recording parameters**, and set fault recording parameters.

Step 2 Select a fault recording mode from the **Fault recorder standard** drop-down list. After you select a mode, the default values of all parameters under the current mode will be displayed. You can modify the parameters as needed.

Step 3 Click **Settings** in the upper right corner. In the pop-up dialog box, confirm the information and click **Save** to apply the settings to the current device.

Step 4 (Optional) Click **Configure synchronization** in the upper right corner, select the desired devices in the pop-up dialog box, and click **Save** to apply the changes to multiple devices in batch.

--End

7.5.10 General Parameter

Step 1 Click **Device Monitoring > General Parameters** to enter the corresponding page and set the general parameters.

Step 2 Select **Read-back**, set **Register Address**, **Register Number**, and **Address Type**. Click **Read-back** to read the current value of the device.

Step 3 Select **Settings**, set **Register Address**, **Data Type**, and **Set Value**. Click **Save** to apply the changes to an individual device.



For parameters that need to be set, refer to corresponding communication protocol of the inverter.

Step 4 Configure general parameters in batch.

- a. Click **Configure Synchronization** to apply the changes.
- b. Select the desired devices in the pop-up dialog, and click **Save** to apply the changes.

--End

7.5.11 Device Instruction

Users can perform power on, power off, and factory reset operations on SUNGROW inverters. Both individual and batch settings are supported.

Take powering on inverter as an example:

Step 1 Click **Device Monitoring > Device Instruction** to enter the corresponding page.

Step 2 Click  to select needed device type in the drop-down list.

Step 3 Select a device, and click **Boot** to open the dialog box. Click **Boot**.

Step 4 Click **Yes** to power on a specific inverter.

Step 5 Batch powering on inverters.

- a. Select a device, and click **Configure Synchronization** to open the dialog box.
- b. Select the desired devices in the pop-up dialog, and click **Save** to apply the changes.

--End

7.5.12 Device Information

Click **Device Monitoring > Device Information** to view the device information.

Parameter information such as device S/N, device model, and rated active power can be viewed.

7.5.13 Dispersion Rate Analysis

The dispersion rate is a key indicator for assessing the health of a PV power plant. It is primarily used to monitor and evaluate the consistency of power generation performance across the PV strings. A low dispersion rate indicates good consistency in current curves among the strings and stable production performance, while a high dispersion rate signifies a significant performance deviation that requires further diagnostic analysis. The one-click dispersion rate diagnosis function allows the O&M team to view the dispersion rates of all strings, quickly locate the abnormal strings, and implement corrective actions promptly. This enhances the efficiency of O&M activities and improves overall production for the plant.

The Logger4000's dispersion rate analysis function utilizes a self-learning algorithm. When a new inverter is connected to the system, the algorithm automatically adjusts its analysis parameters and models based on the variations in time and light conditions and the user's PV array settings. It can identify potential causes of abnormal power generation data from PV modules, providing reference for the O&M team.

NOTICE

Typically, the system can deliver reliable preliminary diagnostic results after collecting data over at least two sunny days from the inverter. Ensure the Logger4000 is powered on at night, as the algorithm engages in self-learning during this time, to allow for effective data analysis and model optimization.



PV brackets equipped with a tracking feature will adjust their orientations and angles based on the sun's position, which may compromise the accuracy of dispersion rate analysis results. Therefore, it is recommended that dispersion rate analysis be conducted only for plants with fixed PV brackets.



The firmware version of Logger4000 should be P028 or later. See [7.8.16 Viewing the Firmware Version](#) for details.

7.5.13.1 Enabling Dispersion Rate Diagnosis



Enable dispersion rate diagnosis via the user interface to use this function.

Step 1 Choose **Intelligent Analysis > Dispersion Rate Diagnosis** on the navigation bar.

Step 2 Enable dispersion rate diagnosis. This function is turned on by default for P010 (firmware version) or later. For earlier versions, it is off by default, and will remain off even after the firmware is updated to P010 or later.

--End

7.5.13.2 Setting Array Parameters

Differences in the orientation and tilt angle of strings in one PV array can directly affect the dispersion rate calculation results. It is essential to consider the installation environment of the PV array in practice to eliminate factors that may influence the dispersion rate data. This improves the accuracy of the analysis and reduces the need for on-site inspections. Therefore, ensure that all array settings are finalized before proceeding with the one-click diagnosis.

Step 1 Choose **Intelligent Analysis > Dispersion Rate Diagnosis** on the navigation bar.

Step 2 Click **Settings** to open the window for parameter settings.

Step 3 Complete the array settings based on the actual conditions at the site.

- a. Enter a name for the array in **Array Name** for easy identification.
- b. Specify the installation environment for the array in **Geographical Environment**.

The following options are available:

- **Flat Ground** (default)

- **Rooftop (Distributed)**
 - **Mountain**
 - **Water (Pile-supported)**
 - **Water (Floating)**
- c. Indicate whether the PV modules in the array are installed at a consistent angle in **Installation Angle**.
- **Consistent:** All PV modules have the same tilt and orientation, as shown in Figure (a).
 - **Inconsistent:** The tilts or orientations of the PV modules vary, as shown in Figure (b) and (c).

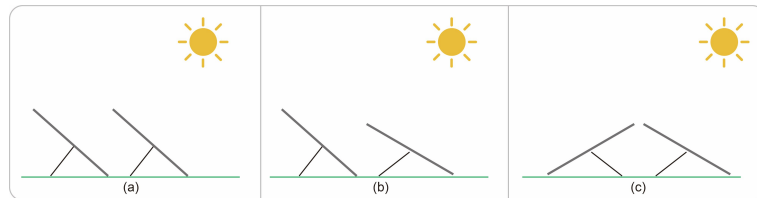

Step 4 Click **Confirm**.

--End

7.5.13.3 Initiating Dispersion Rate Diagnosis

Users can initiate a dispersion rate diagnosis manually when light conditions are favorable.

Prerequisite

- The algorithm self-learning process for the currently connected inverter has been completed.
- Array parameters have been set. See [7.5.13.2 Setting Array Parameters](#) for details.
- The inverter's communication is normal, and it has been online for at least 30 minutes.
- No dispersion rate diagnosis task is currently in progress.



Inverters in the array that are experiencing communication interruptions or have restored communication for less than 30 minutes will not be involved in the dispersion rate diagnosis.



Diagnosis of abnormal environmental conditions is not supported for an inverter that is newly connected in the array.

Step 1 Choose **Intelligent Analysis > Dispersion Rate Diagnosis** on the navigation bar.

Step 2 Click **One-Click Diagnosis**.

Task progress will be displayed in a pop-up window on the Web user interface.

Step 3 After the diagnosis is completed, click **View** to go to the **Diagnosis Results** page and check the result. See [7.5.13.4 Viewing Diagnosis Results](#) for details.

--End

7.5.13.4 Viewing Diagnosis Results

Users can view the dispersion rate grade, dispersion rate data, and alarms after the diagnosis is completed.

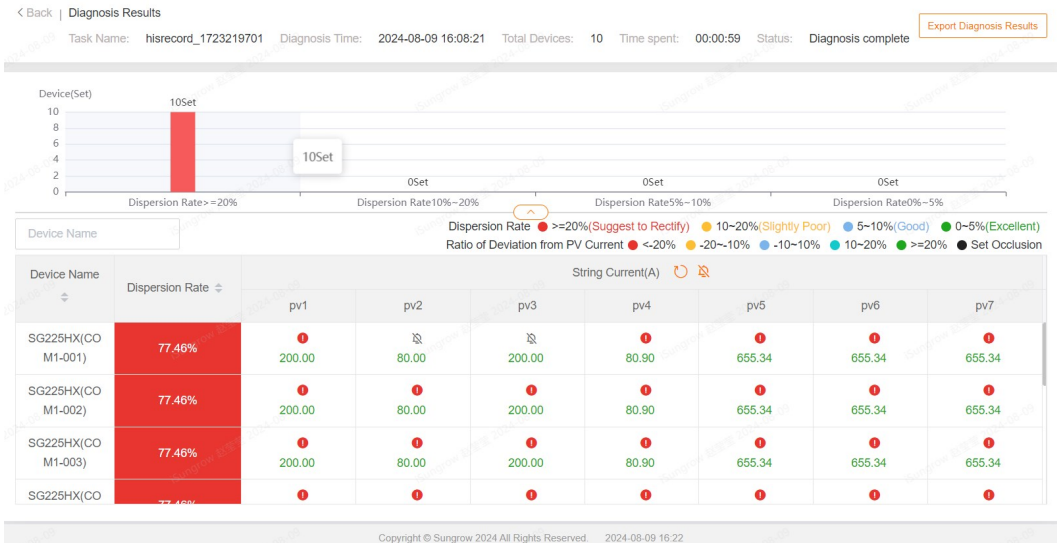

No.	Definition	Description
1	Dispersion rate grade	<p>Inverters are graded based on their dispersion rate. The bar graph illustrates the distribution of inverters across various grades.</p> <ul style="list-style-type: none"> Excellent (0–5%): Branch currents are stable. Good (5–10%): Branch currents are generally satisfactory, with a few branches experiencing relatively low current. Slightly Poor (10–20%): Branch currents are generally not ideal, with a few noticeably lower than others. Suggest to Rectify (over 20%): A few branches are experiencing open circuits, which compromises the plant's production. Corrective actions are necessary.
2	Details list	This list displays the dispersion rate of each inverter, the current of each string, and the alarms.

i Only for a real-time diagnosis task, you can view the string alarms, configure occlusion time settings, and block the alarms as needed within the details list.

Step 1 Navigate to the **Diagnosis Results** page in the following ways.

- View the results of real-time diagnosis tasks: Choose **Intelligent Analysis > Dispersion Rate Diagnosis** and initiate a diagnosis process. After the diagnosis is finished, click **View**. See [7.5.13.3 Initiating Dispersion Rate Diagnosis](#) for details.
- View the results of history diagnosis tasks: Choose **Intelligent Analysis > Dispersion Rate Diagnosis**. Find the **Diagnosis Record** panel at the bottom, and click **View** in the “Action” column of the corresponding task to view its details.

Step 2 To view the diagnosis results for a specific inverter, type its name in the **Device Name** field at the top left of the list.

The **Diagnosis Results** page will then display the diagnosis results for that inverter.

Step 3 Click **Export Diagnosis Results** in the upper right corner of the page to download the diagnosis results to your local system (as an .xlsx file).

--End

7.5.13.4.1 Viewing String Alarms

PV strings with abnormal dispersion rates as well as the potential causes and analysis results of the alarms are shown on the **Diagnosis Results** page. Users can block the alarms not expected to be immediately addressed.

Prerequisite

- The dispersion rate diagnosis has been completed. See [7.5.13.4 Viewing Diagnosis Results](#) for details.

Dispersion rate diagnosis can detect the following three abnormal symptoms.

Table 7-3 Abnormal Symptoms

Abnormal Symptom	Description
Logger abnormal	The string current shows abnormal because data cannot be collected properly due to incorrect logger configuration or device faults.
Inverter operation abnormal	The string current shows abnormal because the inverter cannot operate properly.
Environment abnormal	The string current shows abnormal because the modules are sheltered or due to other environmental factors.

Step 1 If a string sees an abnormal current issue, click  above the current data in the details list to open the **Alarm** window. You can then view the potential causes and analysis results of the alarm.

Step 2 If you do not plan to deal with the alarm in the short term, select the checkbox before the device name and click **Block Alarms**.

In future diagnosis tasks, the blocked alarm will not be shown for this string.



There might be more than one alarm in a string. You can select multiple alarms and block them all.



See [7.5.13.4.2 Unblocking String Alarms](#) for how to unblock the alarms.

--End

7.5.13.4.2 Unblocking String Alarms

After a string alarm reported in a history diagnosis task has been addressed, users can unblock the alarm.

Prerequisite

- The dispersion rate diagnosis has been completed. See [7.5.13.4 Viewing Diagnosis Results](#) for details.

Step 1 In the details list, click **String Current** to the right of  to open the **Blocked Alarm History** window.
All the alarms that are blocked for the PV strings will be shown in "Blocked Alarm History".

Step 2 If an alarm has been addressed, select the checkbox before **Device Name**, and click **Delete** in the "Action" column to remove it from the blocked list.

Step 3 Click **Confirm**.

--End

7.6 Device Maintenance

7.6.1 Device List

The **Device List** function is used for managing devices connected to the Data Logger and configuring addresses for these devices. Devices can be searched and automatically added.

7.6.1.1 Auto Search

"**Auto Search**" is used to search Sungrow string inverters and automatically assign addresses to them.



The Auto search and Add device functions do not support inverters without SNs.



A prompt for automatic address assignment appears only when an actual address conflict exists.



Under PLC communication, the Auto search function applies only when there is no PLC interference. Otherwise, do not use it to avoid search errors.

Step 1 Choose **Device > Device List**.

Step 2 Click **Add device**. In the **Add device** window, select the device type and communication mode. Then the **Add method** option is displayed. Select **Auto search**, and click **Next**.

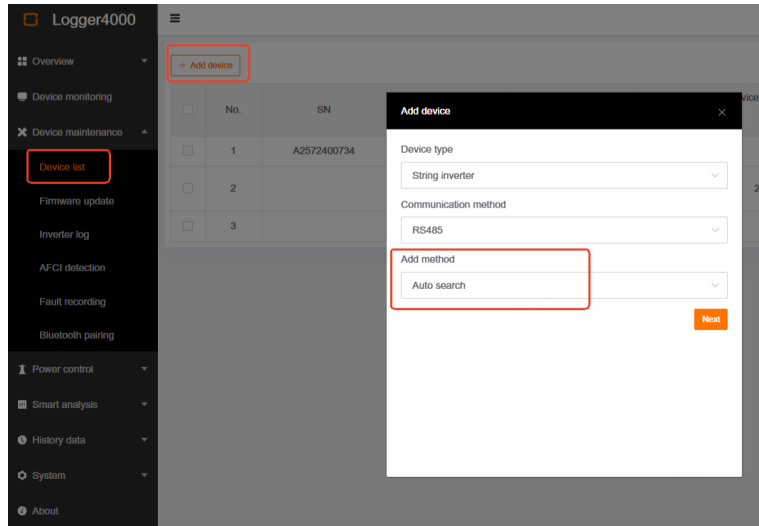

Step 3 In the **Auto Search** window, click **Search**.

Step 4 After the search is complete, you can view the devices that meet the conditions.

--End

7.6.1.2 Export

Step 1 Click **Device > Device List** to enter the corresponding page.

Step 2 Click  to export the device list.

--End

7.6.1.3 Import

Step 1 Click **Device > Device List** to enter the corresponding page.

Step 2 Click  to export the device list.

Step 3 After the device list is exported, user can modify device names in batch.

Step 4 After the modification is completed, save the device list file in the .csv format.

Step 5 Click  to import the .csv file into the Web interface.

--End

7.6.1.4 Add Device

Step 1 Choose **Device > Device List**.

Step 2 Click **Add Device**. In the **Add Device** window, select **Device Type** and complete the required fields as prompted.

Step 3 Select the string inverter and the corresponding communication mode. Available communication modes include PLC and RS485.

--End

- PLC: Whitelist-based addition is recommended.



Under PLC communication, the Auto search and Add in order functions apply only when there is no PLC interference.

- Whitelist addition: Use the mobile app to scan the inverter barcode to generate a whitelist file. Transfer the file to the computer, and click the import icon to import it to the data logger. After whitelist networking is complete, the whitelist networking result is displayed. For adding devices to a new plant, whitelist addition is recommended first to ensure accuracy.



In the iSolarCloud app, tap More > Modbus whitelist configuration > specify the file name and PLC type. Then generate the whitelist file by scanning the inverter QR code or entering the information manually.

- Add in order: Ensure that the array No. and band No. of the data logger primary and secondary nodes are consistent. In addition, obtain the inverter addresses in advance and ensure that the addresses are consecutive.
- Auto search: This method is not recommended under PLC communication.
- RS485: Auto search and Add in order are available.
 - Auto search: This method is recommended when the communication mode is RS485.
 - Add in order: Add the inverter addresses in advance. When adding inverter addresses for the data logger array No., ensure that the addresses are consecutive.

- Only one communication mode can be selected for the same port. If the PLC function is enabled for the port, devices cannot be added through RS485 communication.
- After devices are added through whitelist addition, the **Replace device** button is added to the page, allowing you to update the device SN.

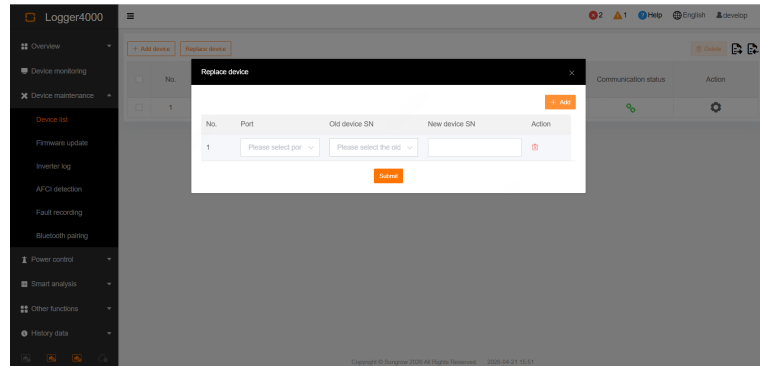



Figure 7-1 Replace Device

7.6.1.5 Edit Device

Step 1 Click **Device > Device List** to enter the corresponding page.

Step 2 Click  to open the **Edit Device** pop-up window. The name of the device connected to the Logger and other parameters can be modified.

The "**Device Name**" is named in the form device model (port number-communication address).
 Take "SG36KTL-M (COM1-7)" as an example. "SG36KTL-M" is device type, "COM1" is the communication port, and "7" is the communication address.

Step 3 Click **Save** to apply the changes.

--End

7.6.1.6 Delete Device

After a device is deleted on site, the user can delete the device from the **Device List** page, to keep device consistency.

Step 1 Click **Device > Device List** to enter the corresponding page.

Step 2 Select the device to be deleted, click **Delete**.

Step 3 Click **Confirm** in the pop-up window, to delete the device.

--End

7.6.2 Inverter Log

Step 1 Click **Device > Inverter Log** to enter the corresponding page.

- Step 2** Select the device running information, and click  to view the export progress.
- Step 3** Click **Export** to store the exported log locally.
- Step 4** Click **Cancel** and then **Confirm** on the pop-up window, to cancel the current operation.
- End

7.6.3 ACFI Activation

- Step 1** Click **Device > ACFI Activation** to enter the corresponding page.
- Step 2** Check the devices that need to self-checking, click **Self Checking** and then **Confirm** on the pop-up window.



The status of the self-checking device must be **Enable**. If the self-checking status is **Disable**, you can click  to set the self-checking status to **Enable**.

- Step 3** The result column shows the self-checking status as Self-Testing. After 7~8 seconds, the self-checking result will be displayed as Self-checking Failure or Self-test Pass.
- Step 4** Click **Clear Fault** to bring up a dialog box showing the status of fault clearing.
- End

7.6.4 Fault Recording

The fault recording module provides advanced electrical event logging and analysis. It includes three submodules: fault recording, grid waveform recording, and RMS waveform recording, designed for equipment fault diagnostics, grid compliance management, and event tracking for specific regional models.

Module Access

From the main interface or left-side navigation panel:

1. Locate and click **Fault recording**.
2. The system will expand the first-level submenu with the following options:
 - **Fault Recording**
 - **Grid Waveform Recording**
 - **RMS Waveform Recording**

Select the relevant submenu based on specific requirements to access the corresponding feature page. Details are provided below.

Fault Recording

This page is designed to assist on-site personnel in troubleshooting inverter faults.

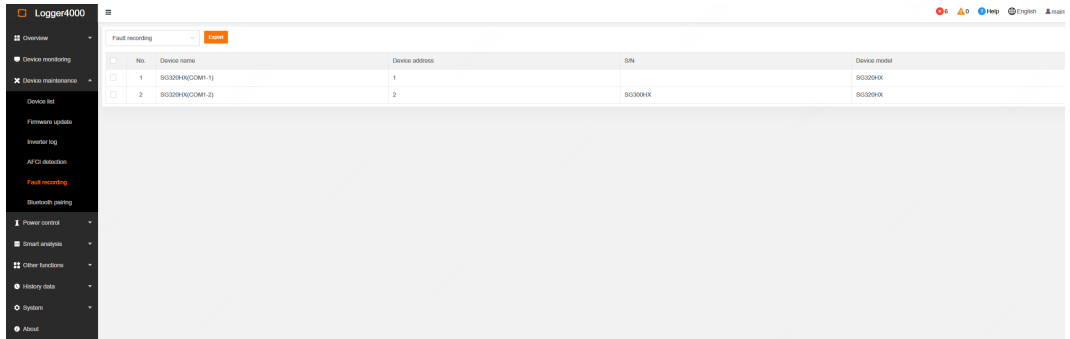

Grid Waveform Recording

This page focuses on grid-compliant recording management and data exchange. Designed in accordance with State Grid, China Southern Grid, and international grid standards, it meets regulatory requirements for grid-connected equipment.

- **Secondary Menu Options:**

- **Full export:** exports complete recording files for comprehensive data analysis.
- **Index export:** exports selected records by event index to improve retrieval efficiency.
- **SER export:** exports sequence of events (SER) data for third-party system analysis.

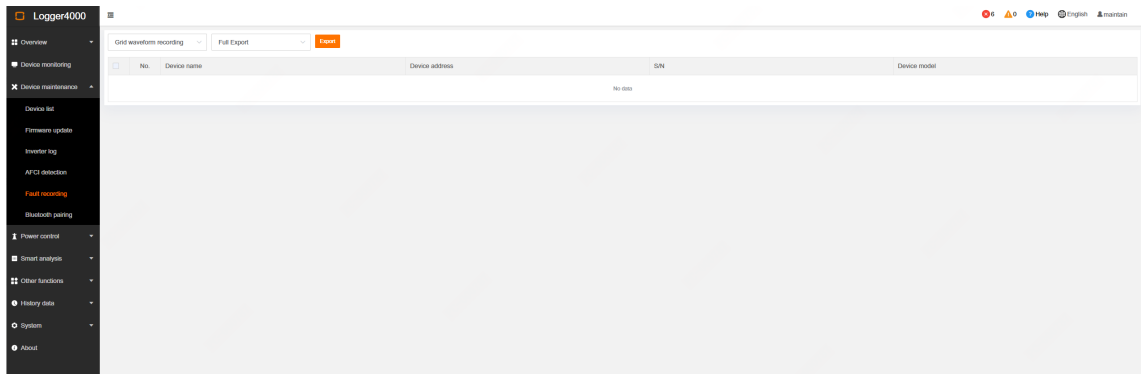

RMS Waveform Recording

This page is designed for RMS event recording on specific North American models.

- **Secondary Menu Options:**

- **Historical RMS values:** stores long-term event records for trend analysis and historical review.
- **Current RMS values:** displays the latest event data in real time for immediate monitoring and diagnostics.

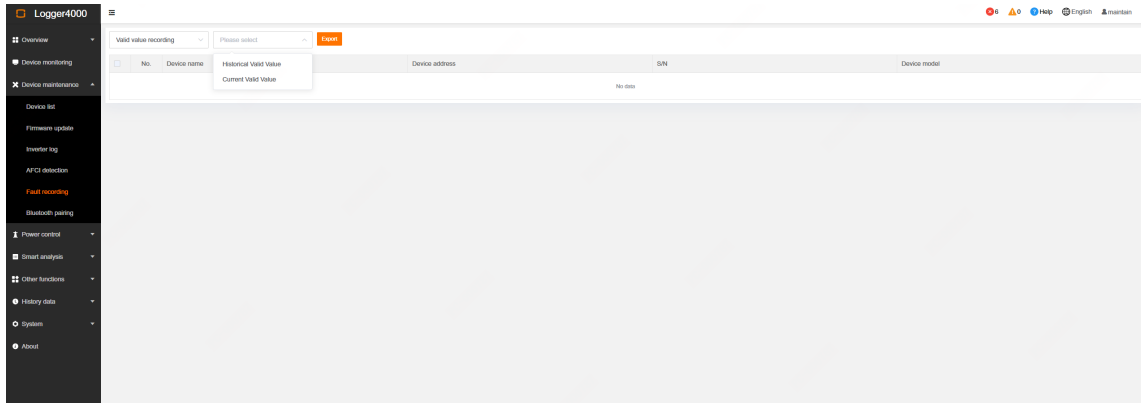

7.6.5 Configuring Bluetooth Pairing for Inverter

The inverter's Bluetooth interface is provided solely for on-site commissioning and maintenance during installation. It is enabled by default for short-range local use and can be disabled for multiple inverters via the Data Logger before grid connection. In large utility plants where Bluetooth is not required, users are advised to disable the function to enhance. During inverter commissioning, a connection is established via Bluetooth to the offline SparkOps app, which is isolated from the public network. This Bluetooth feature is available for initial setup and debugging, typically during the power plant construction phase when LAN communication is unavailable. The Bluetooth function should be disabled immediately after the Logger establishes communication with the inverter. Any subsequent use requires manually re-enabling Bluetooth on the Logger.

Prerequisite

- The connected inverter supports local Bluetooth pairing and is now active within the short-range on-site network. Verify the connection details on the Bluetooth Pairing page.
- The firmware version of the Data Logger is P028 or later. See [7.8.16 Viewing the Firmware Version](#) for instructions on how to check the firmware version.
- Inverters produced after June 2024 are equipped with a dedicated Bluetooth pairing mode.

7.6.5.1 Enabling Bluetooth Pairing

The inverter supports the following two Bluetooth connection methods:

Bluetooth Mode	Description
Pairing Mode	The inverter can establish Bluetooth connections through the offline SparkOps APP only with devices authorized via a pairing code. This mode is suitable for scenarios that require additional protection and device authentication.
Direct Connection Mode	The inverter can establish direct Bluetooth connections with other devices without a pairing code; however, the connection

Bluetooth Mode	Description
	must be established through the offline SparkOps APP. By default, the inverter operates in Direct Connection Mode.

Step 1 Navigate to **Device Maintenance > Bluetooth Pairing**.

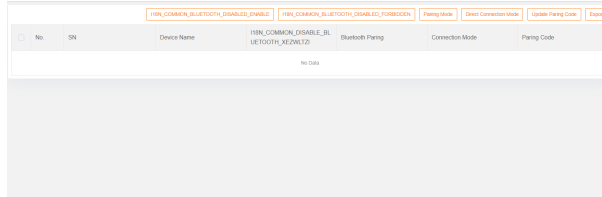

The connected inverters will be displayed in a list on the screen, along with information on whether the inverter model supports Bluetooth pairing.

Step 2 Select the target inverters from the device list, and then click **Enable Bluetooth for Selected Items** in the upper right corner.

Step 3 Click **Pairing Mode** in the upper right corner. Check that the selected inverters and the connection mode are correct and click **Confirm** in the pop-up dialog. The pairing code will then appear on the **Bluetooth Pairing** page.

Step 4 Go to the Mobile App and complete Bluetooth pairing by following the onscreen instructions.

Step 5 (Optional) To manually update the pairing code, select the target inverter from the device list, and click **Update Pairing Code** in the upper right corner. Then, check that the inverter information is correct and click **Confirm** in the dialog.



Pairing Mode, Direct Connection Mode, and Update Pairing Code are available for use only if the inverter supports pairing code and its Bluetooth is enabled.

Step 6 (Optional) To export the inverters' Bluetooth pairing information, click **Export** in the upper right corner of the page.

--End

7.6.5.2 Disabling Bluetooth Pairing

Step 1 Navigate to **Device Maintenance > Bluetooth Pairing**.

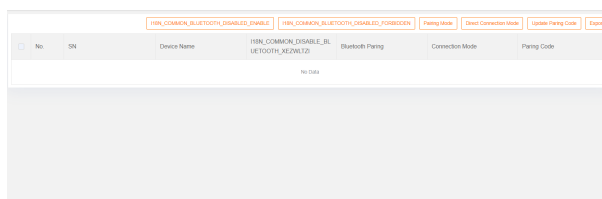

The connected inverters will be displayed in a list on the screen, along with information on whether the inverter model supports Bluetooth pairing.

Step 2 Select the target inverters from the device list, and then click **Disable Bluetooth for Selected Items** in the upper right corner.

Step 3 Check that the information about the selected inverters is correct and click **Confirm** in the pop-up dialog. Then, the inverters' connection mode and pairing code will show "--" on the **Bluetooth Pairing** page.



The connection mode and pairing code will show "--" if the inverter does not support Bluetooth pairing.

Step 4 (Optional) To export the inverters' Bluetooth pairing information, click **Export** in the upper right corner of the page.

--End

7.6.6 (Optional) Winding Temperature Detection

By collecting the apparent power of the inverter and the transformer oil temperature data in real time, the winding temperature detection function can calculate the transformer's winding temperature based on the rated transformer capacity and the winding and top oil temperature rise. It then uploads the real-time temperature data to the monitoring system, displays the alarm and trip information, and allows users to forward such information to the monitoring SCADA. Additionally, after setting the winding temperature alarm and trip parameters, O&M personnel can detect abnormal winding temperatures at an early stage, enhancing the efficiency of plant O&M.



Ensure the device is powered on and has a stable communication during detection. If the device loses power or if the detection time is less than 3 minutes, the data will be considered invalid.



The firmware version of Logger4000 should be P029 or later. See [7.8.16 Viewing the Firmware Version](#) for details. The function can be viewed only if **HV Side Winding Temperature Detection**, **LV Side Winding Temperature Detection**, or both are enabled on the Box-type Transformer Parameter Settings page.

7.6.6.1 Viewing Real-time Data

After completing the box-type transformer parameter and alarm parameter settings, users can check the real-time HV and LV winding temperatures and the alarm and trip information.



Real-time data can be viewed only if **HV Side Winding Temperature Detection**, **LV Side Winding Temperature Detection**, or both are enabled on the Box-type Transformer Parameter Settings page.

Table 7-4 Realtime Values

Parameter	Range	Description
HV Side Winding Temperature	Floating-point format, with an accuracy of 0.1. Unit: °C.	A value will be shown only if HV Side Winding Temperature Detection is enabled. If the detection is disabled or if the

Parameter	Range	Description
HV Side Winding Temperature Alarm	Value: 0 or 1. "0" indicates no alarm, while "1" indicates an alarm due to the temperature exceeding the preset alarm threshold.	detection duration is shorter than 3 minutes, the value shown will be "--".
HV Side Winding Temperature Trip	Value: 0 or 1. "0" indicates no tripping, while "1" indicates tripping due to the temperature exceeding the preset trip threshold.	
LV Side Winding Temperature	Floating-point format, with an accuracy of 0.1. Unit: °C.	A value will be shown only if LV Side Winding Temperature Detection is enabled. If the detection is disabled or if the detection duration is shorter than 3 minutes, the value shown will be "--". This parameter is available only for the double-winding transformer.
LV Side Winding Temperature Alarm	Value: 0 or 1. "0" indicates no alarm, while "1" indicates an alarm due to the temperature exceeding the preset alarm threshold.	
LV Side Winding Temperature Trip	Value: 0 or 1. "0" indicates no tripping, while "1" indicates tripping due to the temperature exceeding the preset trip threshold.	
1# LV Side Winding Temperature	Floating-point format, with an accuracy of 0.1. Unit: °C.	A value will be shown only if 1# LV Side Winding Temperature Detection and 2# LV Side Winding Temperature Detection are enabled. If the detections are disabled or if the detection duration is shorter than 3 minutes, the value shown will be "--". This parameter is available only for the double-split transformer.
1# LV Side Winding Temperature Alarm	Value: 0 or 1. "0" indicates no alarm, while "1" indicates an alarm due to the temperature exceeding the preset alarm threshold.	
1# LV Side Winding	Value: 0 or 1. "0" indicates no tripping,	

Parameter	Range	Description
Temperature Trip		while "1" indicates tripping due to the temperature exceeding the preset trip threshold.
2# LV Side Winding Temperature		Floating-point format, with an accuracy of 0.1. Unit: °C.
2# LV Side Winding Temperature Alarm		Value: 0 or 1. "0" indicates no alarm, while "1" indicates an alarm due to the temperature exceeding the preset alarm threshold.
2# LV Side Winding Temperature Trip		Value: 0 or 1. "0" indicates no tripping, while "1" indicates tripping due to the temperature exceeding the preset trip threshold.



If the temperature reaches the alarm or trip threshold and the detection duration exceeds 3 minutes, the value of winding alarm or trip status in the "Real-time Values" will be "1".

Step 1 Navigate to **Other Functions > Winding Temperature Detection**.

Step 2 Choose the **Real-time Values** tab to view the real-time data.

- **Double-winding Transformer**

Realtime Values		Box-type Transformer Parameter Settings	Alarm Parameter Settings
Parameter Name	Current Value (Unit)		
HV Side Winding Temperature	--°C		
HV Side Winding Temperature Alarm	0		
HV Side Winding Temperature Trip	0		
LV Side Winding Temperature	--°C		
LV Side Winding Temperature Alarm	0		
LV Side Winding Temperature Trip	0		

- **Double-split Transformer**

Realtime Values		Box-type Transformer Parameter Settings	Alarm Parameter Settings
Parameter Name	Current Value (Unit)		
HV Side Winding Temperature	--°C		
HV Side Winding Temperature Alarm	0		
HV Side Winding Temperature Trip	0		
LV Side 1 Winding Temperature	--°C		
LV Side 1 Winding Temperature Alarm	0		
LV Side 1 Winding Temperature Trip	0		
LV Side 2 Winding Temperature	--°C		
LV Side 2 Winding Temperature Alarm	0		
LV Side 2 Winding Temperature Trip	0		

Step 3 View the history winding temperature data. Navigate to **History Data > History Curve**.

Then, click  in the upper right corner to view the history winding temperature data.
--End

7.7 History Data

7.7.1 Log

You can view each user's operation history, for traceback of major events, on the "Operation Log" page.

Table 7-5 Log

User Type	Action	Information Recorded
All users	Login and logout	Username and user IP
System administrator	All operation logs, including but not limited to: add/delete a user, modify user information, empty users, login management, enable or disable develop debugging.	Operating type, target object, settings made, and results
O&M user	Visits and key operations: <ul style="list-style-type: none"> • User login • System Update • Import/export for one-click migration 	Time, type, and details of operation

User Type	Action	Information Recorded
	<ul style="list-style-type: none"> Certificate import 	

Step 1 Click **History Data > Operation Log** to enter the corresponding page.

Step 2 View the operation log on this page. You can click  to filter the results by setting the time and operating type.

--End

7.7.2 Fault Record

You can check the device's fault information within a certain period of time by setting the search criteria.

Step 1 Click **History Data > Fault Record** to enter the corresponding page.

Step 2 Set the start and end time, and click  to select the device name and fault type.

Step 3 Click  to view the fault records in the set time period. The fault records mainly include the following information.

Table 7-6 Description of Parameters

Parameters	Description
Time	Time of fault.
Device Name	The faulty device.
Name	Detailed description of the fault.
Type	The corresponding type of this fault.
Status	-

Step 4 Click  to export the queried information to local for viewing.

--End

7.7.3 History Curve

On this interface users can view the data records of parameters of every device in the plant by selecting the device and the parameter.



Step 1 Click **History Data > History Curve** to enter the corresponding page.

Step 2 Click , select the device and parameter to be viewed, and set the start and end time.

Step 3 Click  to view the history curve within the specified time period.

Users can select to view data records in a table or a chart. Click the icons in the following table to switch between display methods.

Table 7-7 Icon explanation

Icon	Description
	Switch to table form.
	Switch to curve form.

Step 4 Click  to export the queried information to local for viewing.

--End

7.7.4 Syslog Logs

View Syslog Logs

On the **Historical data** page, click **Syslog**, then click **Log record**. Select a time period and a log level to view the user's syslog records within that period.



Syslog logs support storage of up to 11 MB of data. The Web UI supports queries for up to 1000 records.

Export Syslog Logs

Log in with an audit user account. On the **Historical data** page, click the  icon in **Syslog**. After setting a compression password, you can export the syslog logs.



The compression password must be 8 to 32 characters long and include at least three of the following: uppercase letters, lowercase letters, digits, and special characters.

7.8 System

7.8.1 Run Information

- Click **System > Run Information** to enter the corresponding page.

The following information can be viewed:

- **General Information**

Check information like system time, IP address, MAC address.

- **IO Information**

Check information like AI voltage and current values, and DI status.

- **Forwarding Information**

Check the current value of MODBUS-TCP and IEC104 parameters.

7.8.2 System Maintenance

7.8.2.1 Log Export

Step 1 Click **System > System Maintenance** to enter the corresponding page.

Step 2 Click **Log Export** to enter the **Log Export** page.

Step 3 Select the type of logs to be exported, and click **Confirm**.

--End

7.8.2.2 Rebooting

Step 1 Click **System > System Maintenance** to enter the corresponding page.

Step 2 Click **Rebooting** and a warning window will pop up. Click **Confirm** to continue the rebooting operation.

--End



7.8.2.3 One-click Migration

This function is used to back up and export some critical configuration files to the local system. It is also used to import local configuration files to the system, so as to keep its running characteristics consistent with local configuration.

Step 1 Click **System > System Maintenance**.

Step 2 Click **One-click Migration**, and in the pop-up **One-click Migration** window, select **Import** or **Export**, according to your actual needs.

Table 7-8 Parameters description

Parameters	Description
Export	<p>Back up the system configuration files and save them locally.</p> <p> You need to set a password for the zipped file when exporting. The password should meet the relevant requirements.</p>
Import	<p>Import local configuration files to the system.</p> <p> You need to enter the password for unzipping the file when importing, which is the one you set when exporting the file.</p>

--End

7.8.2.4 Backup and Restoration

Click **System > System maintenance > Backup and recovery**.

Backup

1. Click **Backup and restore > Backup**, and click the **Confirm** button to proceed.
2. Set a compression password and click **Confirm**. An encrypted archive will be generated locally.



The password should be 8–32 character long and contain at least three of the following four character types: uppercase letters, lowercase letters, numbers, and special characters.

Restoration

1. Click **Backup and restore > Restore**, and click the **Confirm** button to proceed.
2. Entering the compression password and click **Confirm**.
3. Select the encrypted backup archive to trigger a system restart and complete the restoration.

7.8.2.5 Attribute Management

Step 1 Click **System > System Maintenance** to enter the corresponding page.

Step 2 Click **Attribute Management**.

Step 3 In the pop-up dialog, select **Array Mode**.

Table 7-9 Parameter description

Array Mode	Description
Conventional Mode	The array is involved in dispatching.
Sample Machine Mode	The array is not involved in dispatching.

Step 4 Click **Confirm**.

--End

7.8.2.6 HTTPS Certificate Import

Step 1 Click **System > System Maintenance**.

Step 2 Click **HTTPS Certificate Import**.

Step 3 In the pop-up dialog, click  to select **Certificate File** with a .crt extension, and **Private Key File** with a .key extension.

Step 4 Click **Confirm**. Once the files are imported successfully, there will be a prompt about whether to restart the system.

--End

7.8.2.7 Network Security Mode Configuration

Once network security mode is enabled, the web interface will automatically disable certain ports and display a risk message when attempting to enable them.

Step 1 Click **System > System Maintenance**.

Step 2 Click **Network Security Mode Configuration**.

Step 3 In the pop-up dialog, choose whether to enable **Network Security Mode Configuration**.

Step 4 Click **Confirm**, and the page will prompt you that the changes will take effect after a restart.

--End

7.8.2.8 Import Public Key

To ensure the security of system and verify the authenticity and integrity of update package files, a digital signature technology is employed to perform verification. During the Data Logger update process, it may be required to import the public key corresponding to the update package file in order to complete the digital signature verification procedure.

Step 1 Click **System > System Maintenance**.

Step 2 Click **Public Key Input**.

Step 3 In the pop-up dialog, select the public key file with the .pem extension.

Step 4 Click **Open** to import public key file.

--End

7.8.3 Remote Maintenance



Remote maintenance is disabled by default. Before enabling this feature, the customer must provide informed consent and use the Administrator account to grant manual authorization. Access to the public network must be established through secure encrypted authentication. Remote access becomes effective only after authorization by the Administrator account, and all related operations are governed by the access control policies of the system.

Step 1 Choose **System > Remote Maintenance**.

Remote Maintenance Switch

Enable ▾

Server

Chinese Server ▾

The server address is bound to the iSolarCloud forwarding Modbus ID. If you need to change it, please modify the iSolarCloud server.

Save

Remote service has been connected

<https://rm.isolarcloud.com>

Table 7-10 Parameter Description

Remote maintenance switch status	Description
Disable	Remote maintenance of the data logger is not allowed.
Enable	Remote maintenance of the data logger is allowed.

Step 2 If iSolarCloud forwarding service is enabled, **Server** is bound to the iSolarCloud forwarding address. To modify it, update the iSolarCloud site settings.

Step 3 Click **Save** to enter the **Remote Access** page.

Step 4 Enter the login password and click **Confirm** to proceed.

Step 5 Access information can be saved in the following two ways:

- Click **Copy Remote Access Information** to copy. After copying successfully, save the access information locally.
- Enter an email address and click **Send** to send the access information to the email.

Step 6 Enter the access link in the browser address bar to open the **Remote Maintenance** page. Enter the device S/N and password, then click **Login** to start remote maintenance.

--End

7.8.4 Message Export

Step 1 Click **System > Message Export** to enter the corresponding page.

Parameter	Description
Type	-
Work Mode	-
Port	-

Parameter	Description
Duration	Export the message recorded during the set time

Step 2 After setting the parameters, click **Start** to start recording message. The recording automatically stops when the set time reaches, or the user may manually click **Stop** to stop recording message.

Step 3 Click **Export** to export the message.

--End

7.8.5 System Time

Check whether the current system time is correct, and allows for setting the system's current time and schedule time synchronization for inverters.



- Before enabling NTP, please ensure that there is an available NTP time synchronization server in the local area network and confirm the security of the network environment of the device.
- It is recommended to select the **IEC104** for time synchronization, followed by **iSolarCloud**.
- Only one clock source is effective at a time.

Step 1 Click **System > System Time** to enter the corresponding page.

Inverter Timing

Current Time 2020-03-05 11:26

Clock Source

User Define ▾

Use PC Time

Time Zone

(UTC+08:00) Beijing, Urum ▾

Date

2020-03-05

Time

11:26:32

Save

Step 2 Check **Inverter Timing** to synchronize the device time with the time of the Data Logger.

Step 3 Select the clock source from the drop-down list.

Clock source	Description
User Define	<p>The current system time and time zone can be set in the following two ways:</p> <ul style="list-style-type: none"> • Check Use PC Time to synchronize the time of the Data Logger with the time of the PC. • Click the Time Zone, Date, and Time, and click Save to manually set the time of the Data Logger. <p>It is recommended to select User Define for debugging purposes.</p>
NTP	<p>It allows for the synchronization of time across all devices. Select Time Zone. Fill in Server, set Time Interval, and click Save. This synchronizes the time of the Data Logger with the time of the server.</p>
IEC104	<p>The Data Logger and the SCADA must use the IEC104 communication protocol. Otherwise, setting to IEC104 is invalid.</p>
iSolarCloud	<p>The Data Logger must be connected to iSolarCloud. Otherwise, setting to iSolarCloud is invalid.</p>
Modbus-TCP	<p>The Data Logger and the SCADA must use the MODBUS-TCP communication protocol. Otherwise, setting to Modbus-TCP is invalid.</p>
B Code	<p>Time synchronization using the protocol of B code.</p>

--End

NOTICE

The system time must be set if the Data Logger is used for the first time.

7.8.6 Forward iSolarCloud service settings



- The data forwarding function of the data logger is not available by default. Before enabling this feature, customers must manually authorize it with full awareness and access the public network through secure encrypted authentication. Remote access is only effective after obtaining customer authorization, and the relevant operations are subject to system access control policies.
- iSolarCloud platform has stopped service in the North America Region.



The cloud service interacts with the external network. Please confirm the device's network environment is secure before enabling it.

Step 1 Click **System > Transfer Configuration** to enter the interface.

Step 2 Click the operation bar.  The iSolarCloud forwarding configuration information can be modified.



The default access to the iSolarCloud site is "**Chinese Server**". For the mainland China region, access to "**Chinese Server**"; for the European region, access to "**European Server**"; for the Australian region, access to "**Australian Server**"; and for other regions, access to "**International Server**".
To ensure the normal use of the data logger function, relevant settings need to be made for the router's whitelist. Please refer to [Router Whitelist Settings](#) for parameter configuration.

--End

7.8.7 IEC104

Configure the IEC104 forwarding service for the Data Logger on this page.



Before enabling this switch, ensure the device is connected to a trusted management network.

Server Mode

In the Server Mode, the Data Logger is used a server and connected to PC server to implement data transmission and command delivery.



The local port number is 2404 when configuring IEC104 forwarding service.

7.8.7.1 White List Settings

The device supports whitelist-based access control, allowing communication only with specified IP addresses or network segment in the isolated local area network (LAN). It is recommended to enable the whitelist and restrict the access scope before deployment. If the whitelist is not enabled, the device will only accept communication requests from the local controlled network. All access attempts still require valid authentication credentials to establish a connection.

7.8.7.2 Generate Point Table

Step 1 Turn on the switch of local port 2404.

Step 2 Click **Generate Point Table**, and the default IEC104 point table will be automatically imported to the configuration file.

--End

7.8.7.3 Import IEC104 Forwarding Point Table

Step 1 Click  to open the **Advanced Settings** pop-up window.

Step 2 Click  to import the .zip file.

Step 3 Click **Save**.

--End

7.8.7.4 Export IEC104 Forwarding Point Table

Step 1 Click **System > Transfer Configuration > IEC104** to enter the **Server** page.

Step 2 Click  to export the forwarding point list to the local device. The exported point list includes both .xml and .csv formats.

--End

7.8.7.5 Set IEC104 Dispatch Mode

Step 1 Click **Device Monitoring > Power Regulation Parameters** to enter the corresponding page.

Step 2 Select an inverter on the left and click **Power Regulation Parameters** to set power regulation parameters.

Step 3 In the drop-down list **Quick grid dispatch mode**, perform one of the following operations:

- Select **Enable** to enable the IEC104 Quick mode.
- Select **Disable** to disable the IEC104 Quick mode.

Step 4 In the drop-down list **Swift grid dispatch mode**, perform one of the following operations:

- Select **Enable** to enable the IEC104 Swift mode.
- Select **Disable** to disable the IEC104 Swift mode.



If the **Quick grid dispatch mode** and the **Swift grid dispatch mode** are enabled at the same time, the **Swift grid dispatch mode** is preferentially selected in active power regulation and reactive power regulation.

Step 5 Click **Settings**.

Step 6 Click the **General Parameters** tab to set the general parameters of devices.

Step 7 Choose **Settings** to set **Register Address**, **Data Type**, and **Set Value**. Click **Settings** to apply the changes to the inverter.

Step 8 (Optional) Click **Configure Synchronization**, select the desired devices in the pop-up dialog, and click **Save** to apply the changes to multiple devices in batch.

--End

7.8.8 MODBUS

Configure the MODBUS forwarding service for the Data Logger on this page.



Before enabling this switch, ensure the device is connected to a trusted management network.

7.8.8.1 Server Mode

Step 1 Click **System > Transfer Configuration > MODBUS** to enter the **Server** page.

Step 2 For the white list setting, see [7.8.7.1 White List Settings](#).

--End

7.8.8.2 RTU Mode

Step 1 Click **System > Transfer Configuration > MODBUS** to enter the **Server** page.

Step 2 Click **RTU** to enter the **RTU** page.

Step 3 Select **Serial Port Name**, and enter **Delay**.

Step 4 Click .

--End

7.8.8.3 Modbus TCP Fast Dispatch

Enabling Modbus TCP Fast Dispatch can enhance the responsiveness of power control.

Prerequisite

- When employing Modbus-TCP fast dispatch, an Ethernet switch is set up between the SCADA and the Logger4000's ETH3 or ETH4 rapid control ports, connected using standard Ethernet cables. A standard CAT5E/75cm Ethernet cable will suffice.
- Only configure the IP address for one of the fast dispatch ports (either ETH3 or ETH4), ensuring it is within the same subnet as the SCADA IP wherever possible.



- Firmware version of Logger4000: P019 or above. See [7.8.16 Viewing the Firmware Version](#).
- Modbus TCP Fast Dispatch and GOOSE forwarding service cannot be enabled at the same time.
- Modbus TCP only supports open-loop control.



After enabling the Modbus TCP fast dispatch, ensure the interval between two consecutive dispatch commands meets the following requirements. Otherwise, the inverter might not fully respond to the target values.

- Active power control: The interval should be at least 60 milliseconds.
- Reactive power control: The interval should be at least 30 milliseconds.

Step 1 Click **System > Transfer Configuration > MODBUS** to navigate to the corresponding page.

The **Server** tab page displays.

Step 2 Click **Modbus TCP Fast Dispatch**.

Step 3 In the drop-down list **Switch**, select **Enable**.

Step 4 In the drop-down list **Port**, select the port number of the SCADA.

Step 5 Based on the actual situation of the power station, configure the network parameters for the fast dispatch ports ETH3 and ETH4.

Step 6 To enable **Northbound Communication Abnormal Protection**, under the field **Protection Switch**, select **Enable**.

- a. In the field **Peer IP Address**, enter the IP address of the control device.
- b. In the field **Communication Error Tripping Time**, specify the time to pause before the Data Logger performs protection operations on the inverter.
For example, setting the **Communication Error Tripping Time** to "30" means the Data Logger will wait 30 seconds before limiting the inverter's output power.
- c. In the field **Communication Abnormality Output**, specify the inverter's output power as a percentage when a communication fault is detected.
For example, setting the **Communication Abnormality Output** to "80" means the Data Logger will limit the inverter's output power to 80% of its rated power during a communication fault.
- d. In the field **Communication Error Auto Recovery Time**, specify the waiting time of the Data Logger after the communication resumes.

After this time period, the Data Logger will adjust the inverter's output power or restart the inverter based on the **Communication Output Recovered** settings.

- e. In the drop-down list **Communication Output Recovered**, specify the action the Data Logger should take when the communication resumes.
 - **No Action**: The Data Logger adjusts the inverter's output power based on the last target value issued by the SCADA.
 - **Boot**: The Data Logger first issues a power-on command to the inverter, then adjusts the output power based on the last target value issued by the SCADA. This is suitable when the inverter was shut down due to a communication fault.

For example, setting the **Communication Error Auto Recovery Time** to "30" and the **Communication Output Recovered** to **No Action** means the Data Logger will wait 30 seconds after communication is restored before resuming output power.

Step 7 Click **Save**.

The Web UI will prompt you that the changes will take effect after a restart.

--End

7.8.8.4 Regular Modbus TCP Dispatch Modes

Step 1 Click **Device Monitoring > Power Regulation Parameters** to enter the corresponding page.

Step 2 Select an inverter on the left and click **Power Regulation Parameters** to set power regulation parameters.

Step 3 In the drop-down list **Quick grid dispatch mode**, perform one of the following operations:

- Select **Enable** to enable the Modbus TCP Quick mode.
- Select **Disable** to disable the Modbus TCP Quick mode.

Step 4 In the drop-down list **Swift grid dispatch mode**, perform one of the following operations:

- Select **Enable** to enable the Modbus TCP Swift mode.
- Select **Disable** to disable the Modbus TCP Swift mode.



If the **Quick grid dispatch mode** and the **Swift grid dispatch mode** are enabled at the same time, the **Swift grid dispatch mode** is preferentially selected in active power regulation and reactive power regulation.

Step 5 Click **Settings**.

Step 6 Click the **General Parameters** tab to set the general parameters of devices.

Step 7 Choose **Settings** to set **Register Address**, **Data Type**, and **Set Value**. Click **Settings** to apply the changes to the inverter.

Step 8 (Optional) Click **Configure Synchronization**, select the desired devices in the pop-up dialog, and click **Save** to apply the changes to multiple devices in batch.

--End

7.8.9 Configure Third-Party Cloud Forwarding Service

"Configure Third-Party Cloud Forwarding Service" is used to configure the data logger to forward third-party cloud services.



1. Cloud services exchange data with the public network. Enable this function only after confirming that the device network environment is secure.
2. Third-party cloud forwarding is disabled by default. Before enabling this function, the customer must use the administrator account to grant authorization manually with full awareness and access the public network through secure encrypted authentication. This function takes effect only after authorization by the administrator account, and related operations are managed by the system access control policy.

Step 1 Log in with the maintain account, then choose **System > Transfer Configuration > Third-party Portal** to open the **Third-party Portal** page.

Step 2 Turn on the switch.

Step 3 Click  to open the **Advanced Settings** window.

Step 4 Modify the configuration information and click **Save**.



Set the FTP path in the format "/FTP server directory". For example, in "/SUNGROW", "/" indicates the root directory, and SUNGROW is the directory on the FTP server where data is stored.

--End

7.8.10 Configure GOOSE Forwarding Service

Configure the data logger to forward the GOOSE service.

Prerequisite

- When using GOOSE fast dispatching, install a switch between the backend system and the ETH3 or ETH4 fast dispatching port of the Logger4000 data logger, and connect them with a network cable. A standard Ethernet cable is sufficient, such as a CAT5E cable with a length of 75 cm.
- Configure the IP address for only one of the fast dispatching ports, ETH3 or ETH4. Use the same network segment as the backend IP address whenever possible.



This protocol is not secure and involves risks. Enable it only after confirming that the device network environment is secure.



After the GOOSE forwarding service is enabled, ensure that the interval between dispatch commands issued by the backend system meets the following requirements. Otherwise, the inverter may not fully respond to the target value.

- Active power adjustment: The dispatch interval must be 60 ms or longer.
- Reactive power adjustment: The dispatch interval must be 30 ms or longer.

Step 1 Choose **System > Transfer Configuration > GOOSE** to open the **GOOSE** page.

Step 2 Set **Switch** to **Enable**.

Step 3 Click **Configuration File Export** to export the GOOSE data configuration file to the local computer.

Step 4 Extract the exported archive. Open the .cfg file in the archive with Excel to view and reset the GOOSE data configuration file.

Step 5 Save the updated GOOSE data configuration file.

Step 6 Click **Configuration File Import**, select the saved GOOSE data configuration file, and click **Open** to complete the import.

--End



Enable the **Anti-replay** function to reduce the risk of replay attacks. Set the detection time as required.

7.8.11 Certificate Security Maintenance

Through **System > Certificate Management > HTTPS Certificate/IEC104 Certificate/Modbus TCP Certificate/NTS Time Synchronization Master Server Certificate**, supports importing certificates.



- The equipment comes with default HTTPS certificate/IEC104 certificate/Modbus TCP certificate. It is recommended to import the customer's signed certificate.
- If the NTS function is used, the customer needs to import the NTS server certificate. The NTS certificate is obtained from the NTS server and supports importing X.509 certificates in PEM format.

Import HTTPS Certificate

On the **Certificate Management** page, click **HTTPS Certificate**, and then click **Certificate Import**.

On the **Certificate Import** page, select the certificate file and private key file to upload, and click **Confirm**.

Import IEC104 Certificate

On the **Certificate Management** page, click **IEC104 Certificate**, then click **Certificate Import**. On the **Certificate Import** page, select the certificate file and private key file, and click **Confirm**.

Import Modbus TCP Certificate

On the **Certificate Management** page, click **Modbus TCP Certificate**, then click **Certificate Import**. On the **Certificate Import** page, select the certificate file and private key file, then click **Confirm**.

Import the NTS time synchronization master server certificate

On the **Certificate Management** page, click **NTS Time Synchronization Certificate**. On the primary and standby server page, click **Certificate Import** to import the NTS server certificate.

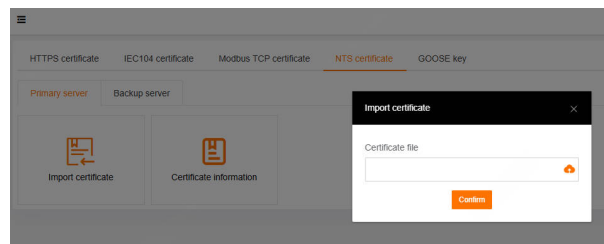

Certificate Expiry Management

After the user successfully logs in, the system will check the HTTPS certificate/IEC104 certificate/Modbus TCP/NTS time synchronization master server certificate during device operation. For certificates that are about to expire or have expired, the system will display a prompt and record the results in the Syslog log.

When the certificate has less than 90 days remaining before expiration, the system triggers an "Expiring Soon" alert.

When the certificate has expired, the system triggers an "Expired" alert.

GOOSE Security Function

GOOSE supports functions such as anti-replay switch and key update.

Replay Protection Function: On the **System > Forwarding Configuration** page, click **GOOSE**, and enable the anti-replay switch. Users can set the inspection time parameters according to their needs.

Key Update: On the **System > Certificate Management** page, click **Goose Key**, select Key Import, and upload the key file to complete the update.

7.8.12 Setting MMS Forwarding Service

Configure MMS forwarding service for the data logger.



- This function is available on LOGGERSV400.001.00.P031 or later.

Step 1 Choose **System > Forwarding configuration > MMS**.

Step 2 Select **Enable** from the **Switch** drop-down list. The switch is **disabled** by default.

Step 3 Click **Configuration file import** to import a .zip configuration file.

Step 4 The import will take effect after a restart. Click **Confirm**.

Click **Configuration file**.

Step 5 (Optional) Click **Configuration file export** to export the imported and effective configuration file to your local system.

--End

7.8.13 Port Parameter

Configure serial ports of the Data Logger.

7.8.13.1 RS485

Step 1 Click **System > Port Parameter > RS485** to enter the **RS485** page.

Step 2 Click  to modify **Baud Rate**, **Parity Bit**, **Stop Bit**, and **PLC Access**. The default value of each parameter are as follows.

Parameter	Default value
Port Function	Collection
Baud Rate	9600
Parity Bit	None
Stop Bit	1
PLC Access	Disable
Fast Scheduling Switch	Disable



When the Data Logger is connected to a device via the serial port, the settings of **Baud Rate**, **Parity Bit**, and **Stop Bit** of the serial port should match those set for the connected device, to ensure normal communication.



Only when COM1 to COM7 ports are connected to the device can the **PLC Access** status corresponding to COM1 to COM7 ports be set to **Enable**. After setting the enable, the baud rate for COM1 to COM7 ports will be automatically modified to 115200. At this time, you can configure the PLC node parameters. For details, see [7.8.14 MPLC \(Broadband PLC\)](#).

--End

7.8.13.2 Ethernet

Step 1 Click **System > Port Parameter > Ethernet** to enter the **Ethernet** page.

Step 2 If **Automatically Obtain IP Settings DHCP** is set to **Open**, the IP address corresponding to the port is invalid. Log in the device through the virtual IP address.

Port	Default IP address	Subnet mask	Gateway	DNS1	DNS2
ETH1	12.12.12.12	255.255.255.0	12.12.12.1	1.2.4.8	8.8.8.8
ETH2	13.13.13.13	255.255.255.0	13.13.13.1	1.2.4.8	8.8.8.8
ETH5	14.14.14.14	255.255.255.0	14.14.14.1	1.2.4.8	8.8.8.8

Step 3 If the parameter Automatically obtain IP settings (DHCP) is set to **Close**, fill in the information such as the **IP Address**, **Subnet Mask**, and **Default Gateway**, and click to save the operation.

--End

7.8.13.3 AI

Step 1 Click **System > Port Parameter > AI** to enter the **AI** page.

Step 2 Select **Input Type**, set **Lower Limit** and **Upper Limit**, and click to save the operation.

AI Port	Input Type	Lower Limit	Upper Limit
AI1	Voltage(V)	0	10
AI2	Current(mA)	4	20
AI3	Current(mA)	4	20
AI4	Current(mA)	4	20
PT1	-	-30	160

AI Port	Input Type	Lower Limit	Upper Limit
PT2	-	-30	160



For Logger4000 with firmware version higher than P028, the upper limit temperature for PT100 is increased from 120°C to 160°C.

Step 3 If there is an external IO device connected to the Data Logger, click **External** to set the AI parameters of this device.

--End

7.8.13.4 Digital Input(DI)

Step 1 Click **System > Port Parameter > DI** to enter the **Built-in** page.

Step 2 Set **Initial Status** to **NO** or **NC**. Click to apply the changes.

Step 3 If there is an external IO device connected to the Data Logger, click **External** to set the DI parameters of this device.

--End

7.8.13.5 DO

Step 1 Click **System > Port Parameter > DO** to enter the **Built-in** page.

Step 2 Set **Initial Status** to **NO** or **NC**, and click to set **Function**, **Action Mode**, and **Pulse Duration**. Click to save the settings.



Selecting **Communication control** under **Function** enables the SCADA and the Data Logger to send commands to the port, while selecting **Manual control** allows commands to be sent to the port manually.

Step 3 If there is an external IO device connected to the Data Logger, click **External** to set the DO parameters of this device.

--End

7.8.14 MPLC (Broadband PLC)



If the data logger has a built-in PLC, you can perform related operations on the built-in PLC, including adding device, auto search, auto frequency hopping, port selection, port parameter settings, log export, and version viewing.

Step 1 Choose **System > MPLC**.

By default, the **MPLC** tab is displayed on the Web.

Step 2 In the list, locate the PLC to be configured, and click in the Action column to open **PLC Settings**.

Step 3 Configure the master node.

- a. Select a communication frequency band from the **Band Num** drop-down list. By default, the communication frequency band is **Band1**.

 When Band1 is in poor communication, you can switch to **Band2** or **Band3**.

- b. In **Array ID**, set the current array ID.

The ID of each array must be unique.

 In the double-split scenario, the two PLCs connected to one data logger must be assigned different array IDs.

 It is not recommended to modify the parameters in **Advanced Settings**. Use the default values.

Step 4 Click **Next**.**Step 5** Configure the slave node.

- a. Select the device.
- b. Click **Synchronization** to synchronize master node parameters to the slave node.

Step 6 After synchronization is complete, click **Logout** to finish configuring the parameters of the master and slave nodes.

The PLC master and slave nodes will automatically restart to apply the changes.

Step 7 Click the **Action** tab to update the PLC master node or export the PLC operation logs.

--End

7.8.14.1 MPLC Auto Frequency Hopping

If communication between the Data Logger and inverter fails (e.g., the port enabled PLC has a packet loss rate exceeding 0.5% or some inverters frequently go offline), you can enable the automatic frequency hopping feature to improve reliability.

Prerequisite

- Firmware version of the Data Logger: P025 or above. See [7.8.16 Viewing the Firmware Version](#).

 To check the packet loss rate, navigate to the page **System > Run Information**.

Step 1 Click **System > MPLC > Action** to navigate to the corresponding page.**Step 2** Click **MPL Auto Frequency Hopping**.**Step 3** In the pop-up dialog, select the MPLC link that requires automatic frequency hopping.**Step 4** Click **Confirm**.

In the dialog box that appears, select the MPLC links that require auto-frequency hopping. Progress will be shown, and completion is indicated by the progress bar reaching 100%.

--End

7.8.14.2 One-Click MPLC Diagnosis

When there is a communication abnormality between the data collector and the inverter, you can use the one-click diagnosis feature to view possible fault causes and repair suggestions.

Prerequisite

- Firmware version of the Data Logger: P025 or above. See [7.8.16 Viewing the Firmware Version](#).

Step 1 Click **System > MPLC > Action** to navigate to the corresponding page.

Step 2 Click **One-Click MPLC Diagnosis**.

Progress and results of diagnostics will be displayed in the dialog box.

Step 3 Follow on-screen instructions to address any identified faults.

Step 4 Click **Export** to save the diagnostic results locally.

--End

7.8.15 More

Step 1 Click **System > More** to enter the corresponding page.

Step 2 Select state of **Auto Online** from the drop-down list: **Disable** or **Enable**.

- If set to **Enable**, parameters of string inverters developed by SUNGROW can be automatically added without additional operations on the Web.
- If set to **Disable**, the above operations are not supported.

Step 3 In the drop-down list **Set Islanded Inverter to Offline**, select **Enable** or **Disable**.

- If you select **Enable**, when the inverter that communicates with the Logger via PLC is in islanding state, the Logger sets the inverter communication status to offline.
- If you select **Disable**, the above operations are not supported.



The firmware version of the Data Logger is P028 or later. See [7.8.16 Viewing the Firmware Version](#) for instructions on how to check the firmware version.

--End

7.8.16 Viewing the Firmware Version

Check the firmware information of the Data Logger.

Step 1 Click **About** to navigate to the corresponding page.

Step 2 Click the field corresponds to **Version** five times to check the firmware version.

Firmware Information	
Name	Version
Device S/N	A2024010915
Version	LOGGER4000_V01_V01_A

The firmware version of the Data Logger is identified by Product Release Software Version, formatted as "LOGGER-SV400.001.00.P[XXX]". For easier recognition, the firmware version is often shortened and referred to as "P[XXX]."

Information	
Name	Value
Product Release Software Version	LOGGER-SV400.001.00.P020
Product Build Software Version	LOGGER-SV400.001.00.B001
Platform Release Software Version	SUNSHINE-SV100.001.00.P010
Platform Build Software Version	SUNSHINE-SV100.001.00.B006
DRA7DSP1 Software Version	DRA7DSP1-LOGGER4000-1.0.2.4
System Software Version	A15SYS-SV100.003.00.PA04
MPLC(PLC-249)	MPLC_15011.01.10

--End



To add this Data Logger to iSolarCloud, simply scan the QR code on the page **About** using iSolarCloud App. The App will automatically detect the Data Logger's serial number.

8 Updating

Firmware updates provide critical security enhancements and performance optimizations, ensuring devices run stably, securely, and efficiently. Regularly updating firmware can fix security vulnerabilities and performance issues, reducing system failures and maintenance costs. You can update Sungrow inverters, the Data Logger, and PLC nodes through the Web UI.

Update Methods	Description
Update via iConfig	The Web UI checks if the iConfig tool is installed on the same local network as the Data Logger first. If iConfig is installed and the update package is downloaded, the Web UI will display the package that matches the current device.
Update via iSolarCloud	The Web UI will display online update packages from the iSolarCloud that match the current device.



For the installation package and instructions of iConfig, contact SUNGROW customer service.

8.1 Updating SUNGROW Inverters or the Slave Node of PLC

Prerequisite

Prepare the necessary files or configurations based on your chosen update method:

- Update via iConfig: The iConfig tool is installed, and the relevant update package is downloaded.
- Update via iSolarCloud: The connection between the Data Logger and iSolarCloud is established, and there is available update package. See [7.8.6 Forward iSolarCloud service settings](#).



The update process cannot be interrupted once it has begun.

Step 1 Click **Device > Firmware Update** to navigate to the corresponding page.

Step 2 Click **Select a Firmware File**, select the appropriate update method from the dialog. The Web UI will verify which devices are compatible with the uploaded update package.

Step 3 On the page **Firmware Update**, select the devices to be updated, and select **Begin upgrade**.

--End

After updating, you can view details such as the current firmware version, target version number, and the time of the update.

8.2 Updating the Data Logger

Prerequisite

Prepare the necessary files or configurations based on your chosen update method:

- Update via iConfig: The iConfig tool is installed, and the relevant update package is downloaded.
- Update via iSolarCloud: The connection between the Data Logger and iSolarCloud is established, and there is available update package. See [7.8.6 Forward iSolarCloud service settings](#).

Step 1 Click **System > System Maintenance** to navigate to the corresponding page.

Step 2 Click **System Update**, select the appropriate update method from the dialog.

Step 3 Follow the on-screen instructions to complete the update process.



If a pop-up window indicates that the public key file is missing, you need to import the corresponding public key file for the update package before proceeding with the update. Click **System > System Maintenance > Public Key Input** to import the required public key file.

A confirmation dialog box appears. Upon confirmation, the Data Logger will automatically restart to apply the firmware update. The new firmware will take effect after a reboot.

--End

8.3 Update PLC master node

Prerequisite

- Data logger firmware version: P013 and above.

Prepare the corresponding resource file or configuration according to the update method:

- Update via the configuration tool iConfig: The iConfig tool has been installed and the relevant update package downloaded.
- Update via iSolarCloud: Connected to cloud service and there is an available update package currently. See [7.8.6 Forward iSolarCloud service settings](#).



If the current data logger version is P012 or lower, use the **System > System Maintenance > System Update** method to update the PLC main node.

Step 1 Click **System > MPLC > Action** in the navigation bar to jump to the corresponding page.

Step 2 Click **PLC Mode Upgrade**, in the pop-up dialog box, select the update method according to the actual situation.

Step 3 According to the update method, follow the on-screen prompts to complete the update.

--End

9 Grid Dispatching

Upon receiving a valid power dispatch command from an authorized SCADA system or authorized O&M personnel, the Data Logger can promptly adjust the active and reactive power output of the grid-connected inverter to meet grid dispatch requirements.

NOTICE

The parameters related to power control must be set by qualified personnel. Incorrect settings may lead to inverter shutdown and impact energy yield.

9.1 Options for Power Control Method

When adjusting active or reactive power, you can select between two control method: open-loop or closed-loop.

Open-Loop Control

Open-loop control does not rely on feedback from the inverter's actual output. Once the Data Logger sends the initial power control command, no further adjustments are made based on the inverter's output. This control method is suitable for scenarios that require quick adjustments.

Closed-loop control

Closed-loop control depends on feedback from the inverter's actual output. The Data Logger continuously monitors the inverter's output power and compares it to the target power. If any deviation is detected, the Data Logger automatically adjusts the control commands to ensure accuracy and stability in output power. This control method is ideal for scenarios that require precise power adjustments.



To ensure accurate data feedback, closed-loop control requires connecting an smart energy meter or a box transformer with a control device to the Data Logger.

9.2 Selecting Power Control Mode

Both active power limitation and reactive power adjustment support various control methods. You can select based on the scale and needs of your power station.

Mode	Description
Remote Power Control	According to the instructions control the equipment power generation. Recommended for scenarios requiring power

Mode	Description
	adjustment through PPC (Power Plant Controller) or AGC (Automatic Generation Controller).
Local Power Control	Directly control the inverter's photovoltaic power via the Data Logger. This method is suitable for distributed power stations and zero-feed-in scenarios. Recommended when the power station is in a commissioning phase.
Analog Input	Use digital signals from the Data Logger's AI port (e.g., current or voltage) to adjust inverter power.
Digital Input	Use digital signals from the Data Logger's DI port, typically for responding to dry contact signals.
Country Mode	Suitable for meeting specific national or regional grid requirements.
Disable Dispatching	Select this option when the power adjustment has started and the inverter needs to maintain its current state.
Disable Derating	Recommended for scenarios where the inverter needs to maintain maximum power output. For example, during peak energy demand periods, this option ensures active power output is not reduced due to power adjustment. Only supports active power control.
Disable Output	Recommended for scenarios where the inverter needs to stop reactive power output. Only supports reactive power control.

Step 1 Click **Power Control** in the navigation bar, from the expanded menu options, select **Active Power** or **Reactive Power**.

Step 2 On the page **Active Power** or **Reactive Power**, in the drop-down list **Active Control Mode** or **Reactive Control Mode**, select the desired power control method.

--End

9.3 Settings for Active Power Control

Active power control refers to regulating the active power fed from the power station to the grid, thereby optimizing the load distribution in the power system. Upon receiving an active power adjustment request, O&M personnel should select the appropriate active power control method and set relevant parameters on the Web UI to ensure the inverter can timely respond to dispatch commands from the Data Logger or other control devices.

9.3.1 Remote Power Control

- The “Remote Power Control” described in this manual are executed by the customer’s on-site SCADA system within the local isolated network.
- This function is limited to local communication inside the customer’s power plant and does not involve Internet or cloud connectivity, and the inverter cannot be accessed or controlled through any external or public network.
- The function is designed in accordance with the supervisory control and power dispatch requirements defined in IEEE 1547 (Clause 5-6) and IEEE 2800 (Clause 5), which specify that Inverter-Based Resources shall support active and reactive power control via local or remote supervisory systems within the electrical power plant network.

9.3.1.1 Open-Loop Control

Prerequisite

- The **Active Control Mode** is currently set to **Remote Power Control**. Refer to [9.2 Selecting Power Control Mode](#).

Step 1 In the drop-down list **Control Method**, select **Open-loop Control**.

Step 2 In the field **Query Recovery Time**, specify the time to pause data interaction between the Data Logger and the inverter.

When power adjustment starts, the Data Logger temporarily stops regular data reading to prioritize adjusting the inverter’s power output for quick and accurate control.

For example, if **Query Recovery Time** is set to "60," the Data Logger will not collect data from the inverter for 60 seconds after the power adjustment command is received. This might cause a delay in viewing device data via the Web UI or cloud platform during this period.

Step 3 In the field **Frame Delay**, specify the frame interval for the Data Logger to read inverter data.

Step 4 In the drop-down list **Target Value Filter**, select the desired target value filtering method.

When the target value for power adjustment changes dramatically or suddenly, the inverter may need to rapidly adjust its output, which could impact grid stability. By implementing a filtering method, you can ensure a smoother inverter output and minimize negative effects on the grid.

- **Identical Values:** The inverter only responds to the first power adjustment command’s target value.
- **Change Rate \leq 0.5%P_n:** Allows the target value to vary within a certain percentage. If the change rate of the target value between the two consecutive commands is within 0.5% of the inverter’s rated power (P_n), the inverter does not need to adjust its output.
- **Do not Filter:** The inverter responds to any target value for power adjustment.

Step 5 In the field **Filter Time**, enter the time to filter dispatch commands.

During this period, the Data Logger decides whether to respond to the commands based on the target value filtering method.

Step 6 In the drop-down list **Maximum Output Trigger Switch**, select **Enable** or **Disable**.

- If you select **Enable**, you can set the **Maximum Output Trigger Threshold**. When the remote dispatch target value is greater than or equal to **Maximum Output Trigger Threshold**, the Logger sends an active power limit ratio of 100% to the inverter.
- If you select **Disable**, the above operations are not supported.



The firmware version of Logger4000 is P028 or later. See [7.8.16 Viewing the Firmware Version](#) for instructions on how to check the firmware version.

Step 7 Click **Save**.

--End

Once the configuration is complete, you can send further dispatch commands through the SCADA.

9.3.1.2 Closed-Loop control

Prerequisite

- The current **Active Control Mode** is set to **Remote Power Control**. Refer to [9.2 Selecting Power Control Mode](#).
- A gateway meter or a box transformer with monitoring and control devices is connected.

Step 1 In the drop-down list **Control Method**, select **Closed-loop Control**.

Step 2 In the drop-down list **Select Energy Meter or Transformer**, select the meter or transformer for power regulation.

Step 3 In the drop-down list **Control Cycle**, specify the interval at which the Data Logger sends dispatch commands to the inverter.

Step 4 In the field **Error Limit**, specify the allowable error range for the ratio between the difference in actual active power and the target value, relative to the rated power.

If the ratio is within the error range, the power adjustment is considered to have reached the target value. You should adjust this parameter in real-time based on the inverter's output power.

Step 5 In the field **Adjustment Ratio**, set the ratio between the inverter's output power and the target value.

If the adjustment result does not reach the set target value, the Data Logger will adjust according to the set adjustment ratio to achieve the target value. You should adjust this parameter in real-time based on the inverter's output power.

Step 6 Click **Save**.

--End

Once the configuration is complete, you can send further dispatch commands through the backend.

9.3.1.3 Setting Fallback Value in Case of Communication Failure

When there is a communication problem between the Data Logger and the SCADA, SCADA active dispatch commands cannot be properly delivered to the inverter, potentially causing an

uncontrolled state and impacting the grid. To avoid this, you can limit the inverter's power output via the Web UI.



If you do not need to enable additional communication protection, in the drop-down list **Northbound Communication Abnormal Protection**, select **Close** (default option).

Step 1 In the drop-down list **Northbound Communication Abnormal Protection**, select the communication protocol between the SCADA and the Data Logger.

- **Modbus-TCP/IEC104**: The communication protocol is Modbus-TCP or IEC104.
- **Modbus-RTU**: The communication protocol is Modbus-RTU.

A communication fault protection configuration table will appear at the bottom of the page.

Step 2 Configure the communication fault protection parameters.



You can set up to three fallback values for the inverter output power.

- a. Under the field **Protection Switch**, select **Enable** to activate the protection settings.
- b. In the fields **Peer IP Address** and **Port**, enter the IP address and port number of the SCADA, respectively.
- c. In the field **Communication Error Tripping Time**, specify the time to pause before the Data Logger performs protection operations on the inverter.
For example, setting the **Communication Error Tripping Time** to "30" means the Data Logger will wait 30 seconds before limiting the inverter's output power.
- d. In the field **Communication Abnormality Output**, specify the inverter's output power as a percentage when a communication fault is detected.
For example, setting the **Communication Abnormality Output** to "80" means the Data Logger will limit the inverter's output power to 80% of its rated power during a communication fault.
- e. In the field **Communication Error Auto Recovery Time**, specify the waiting time of the Data Logger after the communication resumes.
After this time period, the Data Logger will adjust the inverter's output power or restart the inverter based on the **Communication Output Recovered** settings.
- f. In field drop-down list **Communication Output Recovered**, specify the action the Data Logger should take when the communication resumes.
 - **No Action**: The Data Logger adjusts the inverter's output power based on the last target value issued by the SCADA.
 - **Boot**: The Data Logger first issues a power-on command to the inverter, then adjusts the output power based on the last target value issued by the SCADA. This is suitable when the inverter was shut down due to a communication fault.

For example, setting the **Communication Error Auto Recovery Time** to "30" and the **Communication Output Recovered** to **No Action** means the Data Logger will wait 30 seconds after communication is restored before resuming output power.

Step 3 Click **Save**.

--End

9.3.2 Locally Regulating Active Power

9.3.2.1 Open-Loop Control

Prerequisite

- The **Active Control Mode** is currently set to **Local Power Control**. Refer to [9.2 Selecting Power Control Mode](#).

Step 1 In the drop-down list **Control Method**, select **Open-loop Control**.

Step 2 In the drop-down list **Control Cycle**, specify the interval at which the Data Logger sends dispatch commands to the inverter.

Step 3 In the drop-down list **Instruction Type**, select the designated unit for power regulation.

- **kW**: Adjusts the power by setting the total rated power of the inverter array. Recommended for scenarios where precise control of the inverter's output power is required, such as when a power station needs to comply with grid capacity limits.
- **%**: Adjusts power based on a percentage of the inverter's maximum rated power. Recommended for scenarios where the output needs to be adjusted according to the inverter's capacity.

Step 4 Click **Save**.

--End

After configuration, specify the time and target values for local power control. Refer to [9.3.2.3 Configuring Adjustment Time and Target Values](#).

9.3.2.2 Closed-Loop control

Prerequisite

- The current **Active Control Mode** is set to **Local Power Control**. Refer to [9.2 Selecting Power Control Mode](#).
- For closed-loop control, a gateway meter for power control must be connected.

Step 1 In the drop-down list **Control Method**, select **Closed-loop Control**.

Step 2 In the drop-down list **Control Cycle**, specify the interval at which the Data Logger sends dispatch commands to the inverter.

Step 3 In the drop-down list **Instruction Type**, select the designated unit for power regulation.

- **kW**: Adjusts the power by setting the total rated power of the inverter array. Recommended for scenarios where precise control of the inverter's output power is required, such as when a power station needs to comply with grid capacity limits.
- **%**: Adjusts power based on a percentage of the inverter's maximum rated power. Recommended for scenarios where the output needs to be adjusted according to the inverter's capacity.

Step 4 In the drop-down list **Select Meter**, select the designated meter for power regulation.

Step 5 Based on the configuration of inverter's parameter **Shutdown When Active Power Limit to 0%**, you can set related parameters of Data Logger in case of a meter communication failure.



On the page **Device Monitoring > Power Regulation Parameters**, you can set **Shutdown When Active Power Limit to 0%** to **Enable** or **Disable**.

- a. In the field **Communication Abnormality Output**, specify the target value as a percentage to be issued by the Data Logger when there is a communication failure with the meter.
If **Shutdown When Active Power Limit to 0%** is enabled, and **Communication Abnormality Output** is set to 0%, the the Data Logger sends a shutdown command to the inverters.
- b. When the inverters are shut down due to **Shutdown When Active Power Limit to 0%**, in the drop-down list **Start After Communication Recovery**, select whether the Data Logger should send a power-on command to the inverters when communication with the meter resumes.
 - **Enable:** When the communication resumes, the Data Logger sends a power-on command to the inverter.
 - **Disable:** When the communication resumes, the inverter will remain shut down.
- c. In the field **Start Delay After Communication Recovery**, specify the waiting time for the Data Logger to send a power-on command specify to the inverter after communication is restored.

Step 6 If zero power feed-in is required, in the drop-down list **Wiring Mode**, select the connection mode of the Data Logger based on the actual situation.

- **Direct Connection:** One Data Logger is connected to all inverters, where all the inverters must be string inverters or central inverters.
- **Cascading:** Multiple Data Loggers are cascaded, and this Data Logger is used as the host.

Step 7 In the drop-down list **Feed-in Stop**, select whether the Data Logger should send a shutdown command to the inverter when feed-in power is detected.

- **Enable:** The inverter will shut down when feed-in power is detected by the meter. Select this option when zero power feed-in is required.
- **Disable:** The inverter will remain on even when feed-in power is detected by the meter.

Step 8 Select an option in the drop-down list of **Feed-in Control Mode** based on the type of data collected by the meter.

- **Total Active Power Control:** The meter collects data of three phases on the grid side as feedback values for power regulation.
- **Split-phase Active Power Control:** The meter collects data of a single phase as feedback values for power regulation.



The firmware version of the Data Logger P028 or later supports this step. See [7.8.16 Viewing the Firmware Version](#) for instructions on how to check the firmware version.

Step 9 Click **Save**.

--End

After configuration, specify the time and target values for local power control. Refer to [9.3.2.3 Configuring Adjustment Time and Target Values](#).

9.3.2.3 Configuring Adjustment Time and Target Values

Prerequisite

- The selected power control strategy and related configurations are complete.

The specific time and target values for local power control is presented in a table.

<input type="checkbox"/>	Time	Percentage
<input type="checkbox"/>	⌚ 00:00	33.0
<input type="checkbox"/>	⌚	
<input type="checkbox"/>	⌚	
<input type="checkbox"/>	⌚	
<input type="checkbox"/>	⌚	
<input type="checkbox"/>	⌚	
<input type="checkbox"/>	⌚	
<input type="checkbox"/>	⌚	
<input type="checkbox"/>	⌚	
<input type="checkbox"/>	⌚	
<input type="checkbox"/>	⌚	

[Clear Data](#)



If no additional combinations of time and target values are set, the Data Logger will adjust power according to default values throughout the day.

Step 1 Position the cursor in the column **Time**, and in the time picker, select the time to deliver the power control command.

Time is precise to the minute. The default power adjustment starts at "00:00" and cannot be changed.

Step 2 Depending on the selected **Instruction Type**, enter the target value for active power in the corresponding column **Fixed Value of Active Power** or **Percentage**.



To meet zero power feed-in or anti-backflow requirements, set the target value to "0", indicating that the inverter will not output any active power to the grid. However, to strictly control feed-in power and handle load fluctuations, it is recommended to set the target value to a negative number. After configuration, the load will draw power from the grid instead, ensuring the inverter does not active power is fed into the grid.

Step 3 To delete a specific adjustment time and target value, check the corresponding box in the first column, and click **Clear Data**.

Step 4 Click **Save**.

--End

9.3.3 Regulating Active Power via Analog Input

Prerequisite

- The **Active Control Mode** is currently set to **Analog Input**. Refer to [9.2 Selecting Power Control Mode](#).
- For closed-loop control, a gateway meter for power control must be connected.

Step 1 In the drop-down list **Control Method**, select **Open-loop Control** or **Closed-loop Control**.

Step 2 For **Closed-loop Control**, in the drop-down list **Select Meter**, select the meter for power control.

Step 3 In the drop-down list **Control Cycle**, specify the interval at which the Data Logger sends dispatch commands to the inverter.

Step 4 In the drop-down list **AI Port**, select the AI port that accepts the analog input signals. To configure the AI port parameters, click **AI Configuration** to navigate to the **System > Port Parameter > AI** page. See [7.8.13.3 AI](#).

Step 5 In the drop-down list **Instruction Type**, select the designated unit for power regulation.

- **kW**: Adjusts the power by setting the total rated power of the inverter array. Recommended for scenarios where precise control of the inverter's output power is required, such as when a power station needs to comply with grid capacity limits.
- **%**: Adjusts power based on a percentage of the inverter's maximum rated power. Recommended for scenarios where the output needs to be adjusted according to the inverter's capacity.

Step 6 Depending on the **Instruction Type**, in the field **Min** and **Max**, set the target value range for power control.

- **kW**: the range of **Min** and **Max** is 0.0 kW to 999999.9 kW.
- **%**: The range of **Min** and **Max** is 0 to 100%.

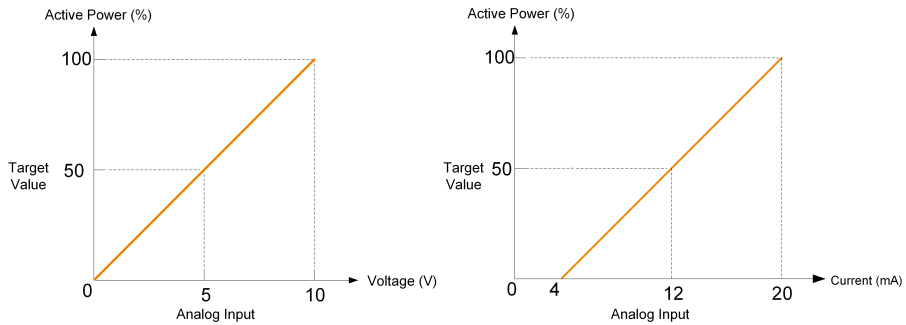

Figure 9-1 Example of the relationship between analog input values and target values

Step 7 Depending on **Instruction Type**, in the field **Step**, set the minimum difference value between two consecutive power control commands.

Step 8 Click **Save**.

--End

9.3.4 Regulating Active Power via Digital Input(DI)

Prerequisite

- The **Active Control Mode** is currently set to **Digital Input**. Refer to [9.2 Selecting Power Control Mode](#).
- For closed-loop control, a gateway meter for power control must be connected.

Step 1 In the drop-down list **Control Method**, select **Open-loop Control** or **Closed-loop Control**.

Step 2 For **Closed-loop Control**, in the drop-down list **Select Meter**, select the meter for power control.

Step 3 In the drop-down list **Control Cycle**, specify the interval at which the Data Logger sends dispatch commands to the inverter.

Step 4 In the drop-down list **Instruction Type**, select the designated unit for power regulation.

- **kW**: Adjusts the power by setting the total rated power of the inverter array. Recommended for scenarios where precise control of the inverter's output power is required, such as when a power station needs to comply with grid capacity limits.
- **%**: Adjusts power based on a percentage of the inverter's maximum rated power. Recommended for scenarios where the output needs to be adjusted according to the inverter's capacity.

Step 5 In the table at the bottom of the page, set the target values for power control corresponding to the digital input signals.

- Based on the dry contact signals received by the DI ports, check the corresponding DI port.
- Depending on the **Instruction Type**, enter a fixed value or a percentage for active power control.



To delete the DI signal configuration, select the checkbox in the first column of the row, and click **Clear Data**.

Step 6 Click **Save**.

--End

9.3.5 Disabling Active Power Control

If the Data Logger has already limited the inverter's active power and you need the inverter to maintain its current state, you can disable active power control.

Step 1 On the **Active Power** page, set **Active Control Mode** to **Disable Dispatching**.

Step 2 Click **Save**.

--End

Once the settings are completed, the inverter will continue to operate with the current active power adjustment limit.

9.3.6 Prohibiting the Inverter from Reducing Power Output

Step 1 On the **Active Power** page, set **Active Control Mode** to **Disable Derating**.

Step 2 Click **Save**.

--End

Once the settings are completed, the Data Logger will stop limiting active power, and the inverter will operate at full load, maintaining an output power level of "100%".

9.4 Settings for Reactive Power Control

- Adjusting reactive power helps maintain grid voltage levels and overall stability. If the grid needs reactive power compensation or injection, O&M personnel should select the appropriate control mode and set the relevant parameters in the Web UI to ensure the inverter responds correctly to the Data Logger or the SCADA.
- The remote power control commands covered in this section are from an authorized SCADA system. All communications are transmitted over an isolated private local area network without any public internet interaction.
- These functions are designed in accordance with the supervisory control and power dispatch requirements defined in IEEE 1547 (Clause 5-6) and IEEE 2800 (Clause 5), which specify that Inverter-Based Resources shall support active and reactive power control via local or remote supervisory systems within the electrical power plant network.

9.4.1 Remote Power Control

Prerequisite

- The **Reactive Control Mode** is currently set to **Remote Power Control**. Refer to [9.2 Selecting Power Control Mode](#).
- For closed-loop control, a gateway meter or a box transformer with monitoring and control devices must be connected.

Step 1 In the drop-down list **Control Method**, select **Open-loop Control** or **Closed-loop Control**.

Step 2 In the drop-down list **Control Cycle**, specify the interval at which the Data Logger sends dispatch commands to the inverter.

Step 3 When **Open-loop Control** is selected, refer to the remote active power control and configure the corresponding parameters. Refer to [9.3.1.1 Open-Loop Control](#).

Step 4 When **Closed-loop Control** is selected, refer to the remote active power control and configure the corresponding parameters. Refer to [9.3.1.2 Closed-Loop control](#).

Step 5 When **Closed-loop Control** is selected, in the drop-down list **Reactive Power Direction**, select whether the reactive power output direction recorded by the meter or transformer matches the inverter.



By default, the SUNGROW inverter outputs inductive reactive power (positive) when the grid needs to increase voltage, and capacitive reactive power (negative) when it needs to decrease voltage.

- **Forward Direction:** The reactive power direction recorded at the grid connection point matches the inverter's reactive power direction.
- **Direction Reverse:** The reactive power direction recorded at the grid connection point is opposite to the inverter's reactive power direction.

Step 6 Click **Save**.

--End

Once the configuration is complete, you can send further dispatch commands through the backend.

9.4.2 Local power control

Configure the parameters for local reactive power control.

Prerequisite

- The **Reactive Control Mode** is currently set to **Local Power Control**. Refer to [9.2 Selecting Power Control Mode](#).
- For closed-loop control, a gateway meter for power control must be connected.

Step 1 In the drop-down list **Control Method**, select **Open-loop Control** or **Closed-loop Control**.

Step 2 In the drop-down list **Instruction Type**, select the designated unit for power regulation.

- **PF:** Adjusts power based on the power factor. Recommended for scenarios where the inverter needs to maintain a specific power factor level.
- **%:** Adjusts power based on a percentage of the inverter's maximum rated power. Recommended for scenarios where the output needs to be adjusted according to the inverter's capacity.

Step 3 When **Open-loop Control** is selected, refer to the local active power control and configure the corresponding parameters. Refer to [9.3.2.1 Open-Loop Control](#).

Step 4 When **Closed-loop Control** is selected, refer to the local active power control and configure the corresponding parameters. Refer to [9.3.2.2 Closed-Loop control](#).

Step 5 When **Closed-loop Control** is selected, in the field **Line Reactive Power Compensation**, estimate and set the reactive power loss in the line.

Step 6 Refer to local active power control and add dispatch time and target values. Refer to [9.3.2.3 Configuring Adjustment Time and Target Values](#).

--End

9.4.3 Regulating Reactive Power via Analog Input

Prerequisite

- The **Reactive Control Mode** is currently set to **Analog Input**. Refer to [9.2 Selecting Power Control Mode](#).
- For closed-loop control, a gateway meter for power control must be connected.

Step 1 In the drop-down list **Control Method**, select **Open-loop Control** or **Closed-loop Control**.

Step 2 When **Closed-loop Control** is selected, configure the following parameters.

- a. In the drop-down list **Select Meter**, select the designated meter for power regulation.
- b. In the drop-down list **Control Cycle**, specify the time to pause data interaction between the Data Logger and the inverter.

Step 3 In the drop-down list **AI Port**, select the AI port that accepts the analog input signals.

To configure the AI port parameters, click **AI Configuration** to navigate to the **System > Port Parameter > AI** page. See [7.8.13.3 AI](#).

Step 4 In the drop-down list **Instruction Type**, select the designated unit for power regulation.

- **PF**: Adjusts power based on the power factor. Recommended for scenarios where the inverter needs to maintain a specific power factor level.
- **%**: Adjusts power based on a percentage of the inverter's maximum rated power. Recommended for scenarios where the output needs to be adjusted according to the inverter's capacity.

Step 5 Depending on the **Instruction Type**, in the field **Min** and **Max**, set the target value range for power control.

- **PF**: The range of **Min** and **Max** is 0.8 to 1.
- **%**: The range of **Min** and **Max** is 0% to 100%.

Step 6 Depending on **Instruction Type**, in the field **Step**, set the minimum difference value between two consecutive power control commands. That is, the minimum adjustment change allowed during adjustment is set. If it is less than the step size, no adjustment instruction is issued and the original adjustment value remains unchanged. If the step size is greater than or equal to the step size, the adjustment command is allowed.

Step 7 For **Closed-loop Control** with **Instruction Type** set to **PF**, in the field **Hysteresis Range**, specify a deadband range that maintains the PF at ± 1 to avoid frequent sudden changes in power factor.

Step 8 Click **Save**.

--End

9.4.4 Regulating Reactive Power via Digital Input(DI)

Prerequisite

- The **Reactive Control Mode** is currently set to **Digital Input**. Refer to [9.2 Selecting Power Control Mode](#).
- For closed-loop control, a gateway meter for power control must be connected.

Step 1 In the drop-down list **Control Method**, select **Open-loop Control** or **Closed-loop Control**.

Step 2 When **Closed-loop Control** is selected, configure the following parameters.

- In the drop-down list **Select Meter**, select the designated meter for power regulation.
- In the drop-down list **Control Cycle**, specify the time to pause data interaction between the Data Logger and the inverter.

Step 3 In the drop-down list **Instruction Type**, select the designated unit for power regulation.

- **PF**: Adjusts power based on the power factor. Recommended for scenarios where the inverter needs to maintain a specific power factor level.
- **%**: Adjusts power based on a percentage of the inverter's maximum rated power. Recommended for scenarios where the output needs to be adjusted according to the inverter's capacity.

Step 4 In the table at the bottom of the page, set the target values for power control corresponding to the digital input signals.

- Based on the dry contact signals received by the DI ports, check the corresponding DI port.
- Depending on the **Instruction Type**, enter a percentage or a power factor for reactive power control.



To delete the DI signal configuration, select the checkbox in the first column of the row, and click **Clear Data**.

Step 5 Click **Save**.

--End

9.4.5 Regulating Reactive Power via Country Mode

Implement power regulations according to the commands issued by the national grid dispatching center.

Prerequisite

- The **Reactive Control Mode** is currently set to **Country Mode**. See [9.2 Selecting Power Control Mode](#).

Step 1 In the drop-down list **Country**, select the country where inverters are located.

Step 2 When the country is set to **Korea**, configure the following parameters.

- In the drop-down list **PPC Type**, select the power plant controller DER-AVM.
- In the field **Forwarding Modbus ID**, enter the Modbus forwarding address (Range: 1~10).

Step 3 Click **Save**.

--End

9.4.6 Disabling Reactive Power Control

Prohibit the Data Logger from performing reactive dispatching on the inverter.

Step 1 On the **Reactive Power** page, set **Reactive Control Mode** to **Disable Dispatching**.

Step 2 Click **Save**.

--End

Once the settings are completed, the inverter will continue to operate with the current reactive power adjustment limit.

9.4.7 Disabling Reactive Power Output

In certain situations, such as when the grid company does not require voltage regulation at the grid-connection point and no reactive power compensation is needed, you can set the inverter to stop reactive power output. This helps maintain overall grid stability and prevents voltage fluctuations caused by reactive power adjustment.

Step 1 On the **Reactive Power** page, set **Reactive Control Mode** to **Disable Output**.

Step 2 Click **Save**.

--End

Once the settings are completed, the inverter's reactive power output will return to "0%".

9.5 Setting Emergency Stop

In cases of grid issues such as short circuits, overloads, or equipment failures, the emergency shutdown function allows for rapid, batch shutdown of inverters. This helps maintain overall grid stability and operational safety.

Prerequisite

- The Data Logger is connected to the emergency stop device.

Step 1 Click **Power Control > Emergency Button** to navigate to the corresponding page.

Step 2 Set **Emergency Button** to **Enable**.

Step 3 In the drop-down list **DI Port**, select the DI port connected to the emergency stop device.

Step 4 In the drop-down list **Inverter Status During Emergency Stop Recovery**, select the inverter's status upon recovery from an emergency stop.

- **Boot:** The Data Logger sends batch power-on commands to the inverters when the emergency stop is recovered.
- **Shutdown:** The inverter will remain in standby mode when the emergency stop is recovered.

Step 5 Click **Save** to apply the changes.

--End



If the inverters remain in standby mode after resetting the emergency stop switch, manually start the inverters through on the **Device Monitoring > Device Instruction** page. If there is any problem, contact SUNGROW.

10 User Management

The system administrator can create and manage O&M user accounts, reset account passwords, set account protection and session security parameters, and enable the developer debugging mode.

Prerequisite

- Firmware version of Logger4000: P018 or above. See [7.8.16 Viewing the Firmware Version](#).
- The user has administrator permissions.

10.1 Initial Usernames and Passwords

User Type	Username	Default Password	Permissions
General user	user	Username + S/N	Monitoring permissions and basic setting permissions only, such as viewing Overview, device monitoring, and some historical data.
O&M user	maintain	Username + S/N	All operations described in this manual by default.
Audit user	auditor	Username + S/N	Audit the operation logs, parameter logs, and syslog logs of all users.
Administrator	administrator	Username + S/N	Add, delete, modify, and clear users; manage sessions; enable or disable developer

User Type	Username	Default Password	Permissions
			debugging; assign certificates.
Developer user	develop	Generate a dynamic password based on the S/N obtained through customer authorization.	After authorization by the administrator, diagnose and clear complex device faults.



For firmware version LOGGER-SV400.001.00.P036B001 and later, the system requires the default password to be changed. Earlier versions do not enforce this requirement. Customers can decide whether to change the default password, but changing the password is still recommended to improve security. On the User management page, the Clear users function is available. Click it to clear the accounts managed under administrator. This function applies only to the maintain, auditor, and user accounts. It is not supported for the administrator or develop account.

10.2 Password Management

1. All passwords have been encrypted and stored.
2. All passwords require strong complexity. The default password must be changed after the first login.
3. If there is a suspicion of password leakage, please change the password immediately. The new password must not be the same as the old one.



Log in as an administrator user and go to the **Password Management** page to dynamically set the following parameters:

- Minimum password length
- Password Complexity
- Number of repeated old and new passwords

After the settings are completed, click Save to take effect.

4. All user passwords have an expiration period. The password validity period can be set by the administrator account, with the configurable range for password validity being 1 to 90 days. Please update your password promptly when it expires.



- By setting different privilege accounts for different users, administrators can enhance system security, improve operational efficiency for different users, and reduce management costs.
- When a regular user logs in and the prompt **Other user login** appears, it is necessary to log out of the other user session first.

10.3 Setting up Administrator Account

The system administrator account must be associated with an email or phone number. This ensures that if you forget your password, it can be reset through verification via your phone or email.

Prerequisite

- Log in to the Web UI as an administrator. See [10.1 Initial Usernames and Passwords](#).

Step 1 Click **Link Account** to navigate to the corresponding page.

Step 2 Enter the necessary contact information.

Depending on the interface language, you can associate the account with the following:

- Email address
- Phone number



If both an email address and phone number are added, the system will prioritize the phone number for verification purposes in the event of password recovery.

Step 3 Click **Save**.

Step 4 To delete the associated email or phone number from the account, click **Unlink**.

--End

10.4 Creating O&M Users

You can create additional operation and maintenance user accounts to meet the needs of operation and maintenance.

The default O&M user account is "maintain" and it cannot be deleted.

As a system administrator, you can create up to 4 additional O&M user accounts.

Username requirements

- May include uppercase letters, lowercase letters, numbers, and underscores (_)
- Must begin with a letter
- Username length should be between 4 to 16 characters

Password requirements

- Must contain at least three of the following four types of characters: uppercase letters, lowercase letters, numbers, and special characters
- Password length should be between 8 to 32 characters



- If the Network Security Mode is disabled, passwords of all users are permanently valid.
- Under Network Security Mode, the administrator can set passwords to expire after a number of days between 1 and 90 for different types of users.

Prerequisite

- Log in to the Web UI as an administrator. See [10.1 Initial Usernames and Passwords](#).

Step 1 Click **User Management** to navigate to the corresponding page.

Step 2 Click **Add** to open the **Add User** dialog box.

Step 3 Enter the desired username and password.

Step 4 In the drop-down list **Permission**, select **O&M User**.

Step 5 Click **Confirm**.

--End

10.5 Deleting O&M Users

Prerequisite

- Log in to the Web UI as an administrator. See [10.1 Initial Usernames and Passwords](#).

Step 1 Click **User Management** to navigate to the corresponding page.

Step 2 Locate the user account you intend to remove, and in the action column, click  .

Step 3 In the confirmation pop-up, click **Confirm** to remove the user account.

Step 4 To remove all user accounts, click **Clear Users**

--End

10.6 Resetting Account Password

10.6.1 Resetting O&M Account Password

Prerequisite

- Log in to the Web UI as an administrator. See [10.1 Initial Usernames and Passwords](#).

Step 1 Click **User Management** to navigate to the corresponding page.

Step 2 Click  to open the **Modify User** dialog box.

Step 3 Reset password.

Step 4 Click **Confirm**.

--End

10.6.2 Resetting Administrator Account Password

Step 1 Open the Web UI of the Data Logger.

Step 2 Enter the username: administrator.

Step 3 Click **Forgot Password** to open the **Modify Password** dialog box.

Step 4 Enter the private key.

You can receive the private key via the email or phone number associated with the administrator account.



If the administrator account is not associated with an email or a phone number, contact SUNGROW Customer Service.

Step 5 Enter the new password and confirm.

Step 6 Click **Confirm**.

--End

10.7 Set account protection and session security parameters

To enhance account security, you can configure relevant parameters to control login behaviors and session validity.

Prerequisite

- Log in to the web portal using the administrator account.

Step 1 Click in the navigation bar. **Login Management**. Jump to the corresponding page.

Step 2 Modify account protection and session security related parameters.

The following parameters can be modified:

- **Number of Illegal Visits:** Limit the maximum number of login attempts for the user. If the number of incorrect password inputs exceeds the specified value, the account will be automatically locked. (Parameters range: 5–20; Default value: 5)
- **Login Timeout:** After the user logs in, no operations within the specified time period will cause the session to time out, and the system will prompt the user to log in again. (Parameters range: 1–60; Default value: 10)
- **User Lock Time:** After an account is locked due to consecutive failed login attempts, set the waiting time for account unlocking. (Parameters range: 1–60; Default value: 10)

Step 3 Click **Save**.

--End

10.8 Enabling the O&M Mode

To permit the develop user to access the Web UI, the administrator needs to activate **R&D Debugging**.



- Under Network Security Mode, the switch for **R&D Debugging** is turned off by default.
- If the Network Security Mode is disabled, the switch for **R&D Debugging** is turned on by default.

Prerequisite

- Log in to the Web UI as an administrator. See [10.1 Initial Usernames and Passwords](#).

Step 1 Click **R&D Management** to navigate to the corresponding page.

Step 2 Turn on the switch.

The switch will automatically turn off after being turned on continuously for 24 hours.

--End

10.9 LDAP Management

Supports login via LDAP, suitable for power stations that provide LDAP services on-site, enabling centralized account management.

Log in with the administrator account, click **LDAP Management**, and enter the LDAP management operation interface.



- When the LDAP login switch is enabled, the system will synchronize the TLS encryption. If the user manually disables TLS encryption, the system will issue a security warning: This protocol is a non-secure protocol and carries risks. Please confirm that the device network environment is secure before enabling it.
- The LDAP server must support TLS 1.2 or higher encryption algorithms to enable communication.

Parameter Name	Explanation
IP address	The IP address of the LDAP server
Port Number	The port of the LDAP server
Base Identifier Name	LDAP Base Distinguished Name
Account	LDAP Server Account
Password	LDAP Server Password



After enabling the LDAP login switch, you need to fill in the configuration parameters and click **Save**. After successfully saving, the interface displays "Operation successful".

After enabling LDAP login, users will no longer see the prompt "Please contact the administrator to enable LDAP" during LDAP login. They can input their username and password to log in.



- LDAP login does not support forgetting the password.
- User authentication information related to LDAP login is stored in the customer's own LDAP server.

10.9.1 System Maintenance

10.9.1.1 Backup and Restore

Log in with the administrator account, then choose **System Maintenance > Backup and Restore**.

Back Up

1. Choose **Backup and Restore > Back Up**, then click **OK** to perform the backup.
2. Set the archive password and click **OK**. The system generates an encrypted archive locally.



The archive password must be 8–32 characters long and include at least three of the following: uppercase letters, lowercase letters, digits, and special characters.

Restore

1. Choose **Backup and Restore > Restore**, then click **OK** to perform the restore.
2. Enter the password for the backup archive and click **OK**.
3. Select the encrypted backup archive. The system restarts and completes the restore.

10.9.1.2 Reset All Settings



After restoring to the factory settings, when logging back into the web interface, users will be prompted to choose whether to enable network security mode.

Step 1 Click **System > System Maintenance** to enter the corresponding page.

Step 2 Click **Reset All Settings** to enter the **Reset All Settings** page.

Step 3 A warning window will pop up, and click **Confirm** to continue the reset all settings operation.

--End



Restoring the factory settings refers to restoring all modified settings to the factory state and will not clear the data.

10.10 Communication Settings

10.10.1 iSolarCloud

1. Log in as administrator and click the **Communication settings** module to go to the **iSolarCloud** submodule.
2. Enable **Communication master switch** to connect to iSolarCloud. This function enables the iSolarCloud communication channel and allows authorized O&M personnel to configure remote maintenance and iSolarCloud access.
3. Click **Cloud-to-device**. Set the authorization validity period as needed, and then click **Confirm** to authorize.



To update the authorization validity period, click **Validity update** to reset the permission period. The extended permission period is calculated from the currently set time.

4. Configure the view and control permissions for authorized O&M personnel. Enable the corresponding function switches as needed.

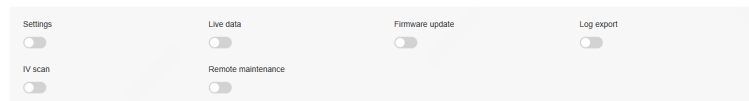

10.10.2 Third-Party Cloud

1. Log in as administrator and choose **Communication settings > Third-party cloud** to enter the **Third-party cloud** subpage.
2. Enable **Third-party cloud** and confirm the authorization prompt. Authorized O&M personnel can configure Third-party cloud. Enabling this function allows device data to be uploaded to the configured server.

11 Routine Maintenance

Due to ambient temperature, humidity, dust, and vibration, the internal components of the Data Logger may age and wear, which may lead to potential failures inside the device. Therefore, it is necessary to perform daily and regular maintenance on the Data Logger to ensure its normal operation and service life.

All measures, which can help the Data Logger to keep good working conditions, are within the maintenance scope.

11.1 Safety Instructions

WARNING

Only qualified and authorized personnel may perform maintenance and other operations on the Data Logger. Do not leave screws, washers or other metal parts in the Data Logger during maintenance. Otherwise, damage may be caused to the device!

WARNING

After the Data Logger stops running, wait at least 5 minutes before performing any operation on it.

Five Safety Rules

The following five safety rules shall be observed during maintenance or troubleshooting of the Data Logger to ensure operators' safety:

- Disconnect the Data Logger from all external connections and internal power supplies.
- Ensure that the Data Logger will not be inadvertently connected.
- Ensure that the Data Logger is voltage-free using a multimeter.
- Connect necessary grounding cables.
- If there are parts in the operation area that may carry voltage, cover them with insulated cloth for insulation shielding.

11.2 Maintenance List

Item	Method
Working environment	<ul style="list-style-type: none">• Ensure that there are no devices emitting strong electromagnetic interference near the Data Logger.

Item	Method
	<ul style="list-style-type: none"> • Ensure that there are no heat sources near the Data Logger. • Ensure that there are no corrosive materials present near the Data Logger.
Hardware	<ul style="list-style-type: none"> • Ensure that the power supply voltage is within the normal range. • Ensure that the wiring connections are secure and reliable. • Ensure that the device is properly grounded.
System cleaning	<ul style="list-style-type: none"> • Ensure that the enclosure, circuit board and other components are clean. • Check for dust or obstructions in the ventilation holes.
Terminal and cable connection	<ul style="list-style-type: none"> • Check whether the screws of control terminals are loose. Tighten them with a screwdriver if necessary. • Check whether the copper bars or screws are oxidized and discolored. • Visually inspect the connections and distribution of terminals and cables.
Software	<ul style="list-style-type: none"> • Log in to the web interface to check the device's communication status. • Log in to the web interface to review and adjust the parameters of the Data Logger. • Log in to the web interface to check the software version of the Data Logger.

12 Troubleshooting

12.1 Safety Instructions

DANGER

Before proceeding with any troubleshooting, ensure that the grounding cable is properly grounded. Failure to do so may result in a severe electric shock hazard for the operators.

12.2 Common Faults and Corrective Measures

The following table shows common faults and corresponding corrective measures. If the fault still persists after you perform the corrective measures as described in this manual, contact SUNGROW with the following information provided:

- Serial number of the Data Logger, date of manufacture, and software version
- Serial number of the Data Logger, date of manufacture, and software version
- Fault information and a brief description of the fault
- Pictures of the fault occurrence site (if on-site conditions permit)

Fault	Possible Cause	Corrective measure
Failure to log into the Web	Cable connection between the PC and the Data Logger is abnormal.	Check whether the PC is normally connected to the port ETH of the Data Logger.
	PC network signal is abnormal.	Check whether the network signal icon of the PC is abnormal.
	IP address of the PC is incorrect.	Manually set the IP address of the PC network port to be in the same network range as the IP address of the Data Logger.
	The PC cannot normally receive data.	Use the shortcut key Win+R to call up the command prompt. Input ping 12.12.12.12 (IP address of the Data Logger) to check

Fault	Possible Cause	Corrective measure
Communication failure between the Data Logger and devices connected to it		whether the PC can receive data packets.
	Conflicts with the network card, antivirus software, or other factors.	If PC cannot receive data packets, disable any other network cards, antivirus software, or firewalls, and then retry the operation.
	The RS485 cable connecting the device and the Data Logger is abnormal.	Inspect the RS485 communication cable between the device and the Data Logger for any short circuits, open circuits, or reverse connections between RS485-A and RS485-B.
	Configuration of the serial port is inconsistent with the RS485 parameters of the device.	Log into the Web, and on the System > Port Parameter > RS485 page, verify whether the port configuration is consistent with the RS485 parameters of the device.
	The current device is an inverter, and the inverter cannot be added to the Web system in automatic search manner.	Manually input the inverter address to add the inverter to the Web system.
	Communication connection status between the Data Logger and the device is abnormal.	Log into the Web, and on the Device Monitoring page, verify whether the communication status is normal. If there is an abnormality, check for duplicate addresses on the same port. If the fault persists, contact SUNGROW Customer Service.
no data exchange between the logger and ModbusRTU	The RS485 cable connecting the device and the Data Logger is abnormal.	Inspect the RS485 communication cable between the device and the

Fault	Possible Cause	Corrective measure
no data exchange between the logger and ModbusTCP		Data Logger for any short circuits, open circuits, or reverse connections between RS485-A and RS485-B.
	COM port parameter is incorrectly set on the web interface.	Log into the Web, and on the System > Port Parameter > MODBUS > RTU page, verify whether the COM port is set to Forwarding is Prohibited . Check whether the serial port parameter is correct.
	Collection address of the device does not match with access address.	On the Device > Device List page, verify if it is consistent with Forwarding Modbus ID .
	Protocol configuration of the ModbusRTU is inconsistent with that of the device.	Ensure that the protocol configuration of the ModbusRTU is consistent with that of the device.
	Network connection between the Data Logger and ModbusTCP is incorrect.	Verify the network connection between the Data Logger and the ModbusTCP to ensure it is configured correctly.
	Configuration of port ETH of the Data Logger is incorrect.	Set the IP address of the port ETH of the Data Logger to the one that the ModbusTCP needs to access.
	Collection address of the device does not match with forwarding address.	On the Device > Device List page, verify if it is consistent with Forwarding Modbus ID .
	Protocol configuration of the ModbusTCP is inconsistent with that of the device.	Ensure that the protocol configuration of the ModbusTCP is consistent with that of the device.

Fault	Possible Cause	Corrective measure
no data exchange between the logger and IEC104	Network connection between the Data Logger and IEC104 is incorrect.	Verify the network connection between the Data Logger and the IEC104 to ensure it is configured correctly.
	IP address of the forwarding device or IEC104 IP address is incorrect.	Log into the Web, and on the System > Port Parameter > IEC104 page, click White List Setting to verify whether whitelist is enabled. If enabled, only IP addresses of white list setting are allowed to access the Data Logger.
	The communication device is abnormal.	Verify if there are any abnormalities in the device communication.
	IEC104 parameters are incorrectly configured.	Ensure that the IEC104 parameters are correctly configured.
Inverter upgrading failed	The upgrading file is invalid.	The upgrading file is invalid, for example, the file is encrypted or the file is named incorrectly.
	The type of to-be-upgraded inverter is inconsistent with the upgrading file.	Check whether the type of to-be-upgraded inverter is consistent with the upgrading file.
	Communication connection is abnormal.	Check whether the communication cable is correctly connected, and try to upgrade the inverter again if so. If the fault persists, contact SUNGROW Customer Service.
Parameter setting failed	Communication connection is abnormal.	Log into the Web, and verify whether the communication

Fault	Possible Cause	Corrective measure
		<p>status is normal on the Device Monitoring page.</p>
<p>The fast dispatch instruction in Goose messages is not issued to the inverter when an external communication module is connected</p>	<p>The current operation mode of the inverter does not support the parameter setting.</p> <hr/> <p>Fast Scheduling Switch is disabled.</p> <hr/> <p>No inverter is added to the MPLC port.</p>	<p>Identify the current operation status of the inverter. For example, the active power rising speed and drop speed can be set only when the speed control switch of the inverter is enabled.</p> <hr/> <ul style="list-style-type: none"> • Log into the Web. • click System > Port Parameter > RS485, to set Fast Scheduling Switch to Enable. <hr/> <ul style="list-style-type: none"> • Log into the Web. • Click Device > Device List > Add Device. • Click the function column of corresponding DO and select Communication Control.
<p>SCADA cannot control DO by 104</p>	<p>DO control type is not configured as "Communication Control"</p>	<ul style="list-style-type: none"> • Log into the Web. • Click System > Port Parameter > DO, and click the function column of corresponding DO and select Communication Control.

13 FAQ

How many types of communication ports does the Data Logger support, what are the corresponding ports, and how to set the port parameters?

Type	Port name	Default values
Ethernet	ETH1, ETH2 and ETH5	For default parameters, see 7.8.13.2 Ethernet
RS485	A1B1~A7B 7	Baud rate: 9600, Check bit: Null, Data bit: 8, Stop bit: 1.
MPLC	L1, L2, L3	Baud rate: 115200, Check bit: Null, Data bit: 8, Stop bit: 1.

What are the forwarding protocols supported by the Data Logger?

Protocol Type	Description
ModbusRTU/ModbusTCP	The Data Logger sends the collected data of devices (such as inverter, combiner box, Meteo Station) to the SCADA. The SCADA allocates forwarding addresses to these devices, thereby accessing and obtaining the data of the devices.
IEC104	<ol style="list-style-type: none">1. Add or search devices on the Web interface (such as inverter, combiner box, Meteo Station).2. Export the IEC104 point table on the System > Transfer Configuration > IEC104 page. The point table shows measuring point information of connected devices.
FTP	The Data Logger transfers the data of the collected equipment (such as inverter, PV combiner box, Meteo Station, etc.) to the remote monitoring system through the FTP protocol.

Protocol Type	Description
MQTT	The Data Logger transfers the data collected from devices (such as inverters, PV combiner box, Meteo Station, etc.) to the remote monitoring system through the MQTT protocol.

How to log into the system via develop account and how to obtain the password?

Generally, the O&M users have access to most of onsite configurations. If there is any needs to use the develop account, contact SUNGROW to obtain a temporary password. The temporary password is valid only as of this day.

How to connect multiple Data Loggers to the SCADA through the network?

1. Data Loggers closer to the Ethernet switch (□ 100m) are connected to the Ethernet switch by using network cables.
2. Data Loggers relatively far away from the Ethernet switch (□ 100m) are connected to the Ethernet switch by using routed fiber optic cables.
3. Once the connection is established, it is important to set the IP addresses of multiple Data Loggers to the same network segment, ensuring that there are no duplicate IP addresses assigned.

14 Appendix A: Technical Data

Communication	
Inverter communication	RS485, MPLC
PC communication	10 / 100 Mbps Ethernet / RS485
Max. Communication Range	
RS485	1000m
Ethernet	100m
MPLC*	1000m
Communication Ports	
RS485	7
Ethernet	5 × 10/100Mbps ETH1/2: Ethernet port ETH3/4: Fast dispatch port ETH5: Reserved port
Digital input	16
Digital output	4
Built-in MPLC	1
PT100/PT1000	2
Analog input	4 (AI1 □0~10 Vdc □AI2~AI4 □4~20 mA)
Power Supply	
AC input	100V~277Vac, 50 / 60Hz
DC input	24Vdc, 1.25A
Power consumption	<ul style="list-style-type: none"> • Typ. 18W • Max. 30W
Environment	
Operating temperature	- 30°C~+60°C

Storage temperature	-40°C~+70°C
Operating humidity	≤ 95%, no condensation
Elevation	≤4000m
IP rating	IP20
Mechanical Parameters	
Dimensions (W x H x D)	440×44×224 mm
Weight	3 kg
Installation	Rack-mounting, wall-mounting

15 Appendix B: Related Drawings

Rack-Mounted Drawings

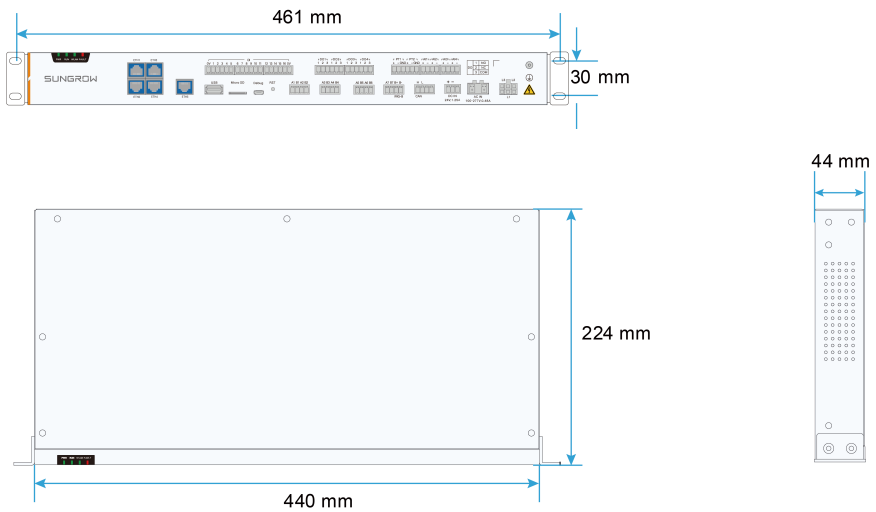

Wall-Mounted Drawings

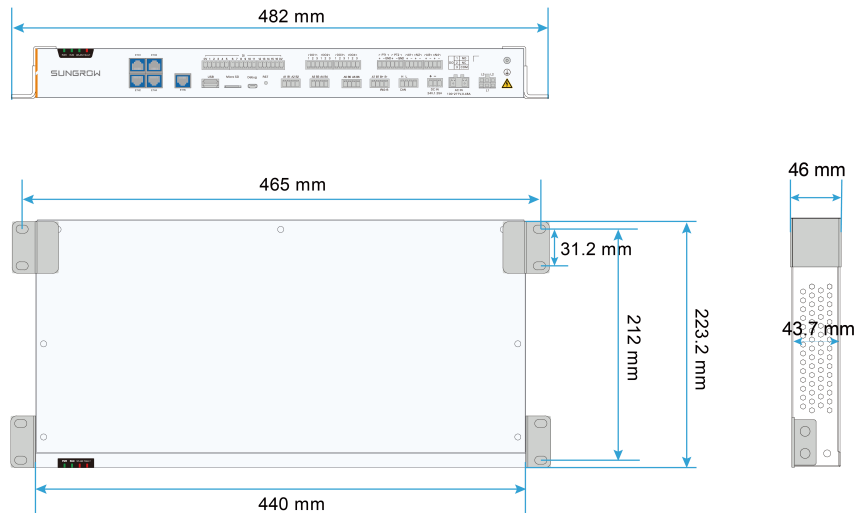

16 Appendix C: General Information

16.1 Quality Assurance

Evidence

During the warranty period, the customer shall provide the product purchase invoice and date. In addition, the trademark on the product shall be undamaged and legible. Otherwise, SUNGROW has the right to refuse to honor the quality guarantee.

Conditions

- When product faults occur during the warranty period, SUNGROW will provide free repairs or replace the product with a new one.
- After replacement, unqualified products shall be processed by SUNGROW.
- The customer shall give SUNGROW a reasonable period to repair the faulty device.

In the following circumstances, SUNGROW has the right to refuse to honor the quality guarantee:

- The equipment is damaged during transport.
- The equipment is improperly installed.
- The equipment is improperly modified.
- The equipment is improperly used.
- The equipment operates under harsh conditions beyond those described in this document.
- The equipment is damaged by an abnormal natural environment.

16.2 Software Security Update Notes

The software security update period for this product is identical to the warranty period of the product. During the warranty period, if any security vulnerabilities or compatibility issues are identified, corresponding software patches or security updates will be provided.

16.3 Contact Information

If you have any questions about this product, please reach out to us. In order to be more responsive and provide you with better service, please offer the following information:

- Model of the device
- Serial number of the device
- Fault code/name

- Brief description of the problem

HQ Tel: 0551 - 6532 7878 / 0551 - 6532 7877

For detailed information, see <https://www.sungrowpower.com/headquarter.html>.

SUNGROW

Sungrow Power Supply Co., Ltd.

www.sungrowpower.com

M-D-000286